

---

# ROBE

---

## ROBIN iBOLT™

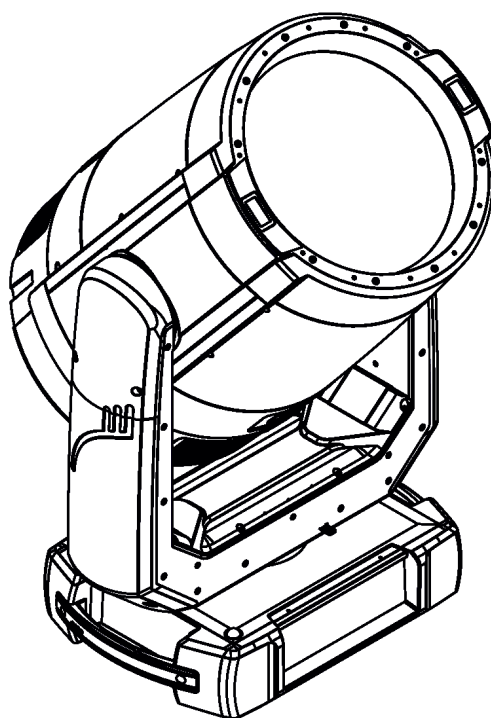

**ROBE**  
Innovative  
Technology

QR code for user manual



---

### USER MANUAL

---

ROBE® lighting s.r.o. • Czech Republic • [www.robe.cz](http://www.robe.cz)

Version 2.8

# Robin iBOLT

## Table of contents

|   |           |
|---|-----------|
| <b>1. Safety instructions and operating determinations</b> .....        | <b>3</b>  |
| <b>2. Loader case manipulation</b> .....                                | <b>9</b>  |
| <b>3. Fixture exterior view</b> .....                                   | <b>11</b> |
| <b>4. Installation</b> .....  | <b>12</b> |
| 4.1 Connection to the mains .....                                       | 13        |
| 4.2 Replacing rotating gobos .....                                      | 14        |
| 4.3 Rigging the fixture .....   | 18        |
| 4.4 DMX-512 connection.....   | 21        |
| 4.5 Ethernet connection .....   | 22        |
| 4.6 Wireless DMX operation .....  | 24        |
| 4.7 Stage mode and Sky mode.....  | 25        |
| 4.8 Allowed zoom/focus positions .....                                  | 27        |
| 4.9 Sky mode zone definition .....                                      | 28        |
| 4.10 Fixture operation with LIDAR .....                                 | 30        |
| <b>5. Checking the IP65 integrity of the fixture</b> .....              | <b>31</b> |
| <b>6. Operating the fixture at ambient temperatures below 0°C</b> ..... | <b>33</b> |
| <b>7. Standby mode</b> .....  | <b>34</b> |
| <b>8. Remotely controllable functions</b> .....                         | <b>35</b> |
| <b>9. Control menu map</b> .....  | <b>38</b> |
| <b>10. Control menu</b> .....   | <b>42</b> |
| 10.1 Tab "Address" .....  | 45        |
| 10.2 Tab "Information" .....  | 45        |
| 10.3 Tab "Personality" .....  | 49        |
| 10.4 Tab "Manual Control".....  | 51        |
| 10.5 Tab "Service" .....  | 51        |
| <b>11. Software update</b> .....  | <b>53</b> |
| <b>12. RDM</b> .....  | <b>54</b> |
| <b>13. Error and information messages</b> .....                         | <b>55</b> |
| <b>14. NFC</b> .....  | <b>59</b> |
| <b>15. Cleaning</b> .....   | <b>59</b> |
| <b>16. Maintenance</b> .....  | <b>60</b> |
| 16.1 Fixture watertight covers and torques of covers screws .....       | 62        |
| 16.2 Torques of Pan/Tilt motors screws .....                            | 66        |
| 16.3 Checking and replacing the silica gel desiccants .....             | 67        |
| 16.4 Disposing of the product .....                                     | 69        |
| <b>17. Robe Ethernet Access Portal (REAP)</b> .....                     | <b>70</b> |
| <b>18. Technical Specifications</b> .....                               | <b>78</b> |
| <b>19. ChangeLog</b> .....  | <b>82</b> |

**FOR YOUR OWN SAFETY, PLEASE READ THIS USER MANUAL CAREFULLY  
BEFORE YOU INITIAL START - UP**



This device has left our premises in absolutely perfect condition. In order to maintain this condition and to ensure a safe operation, it is absolutely necessary for the user to follow the safety instructions and warnings in this manual.

The manufacturer will not accept liability for any resulting damages caused by the non-observance of this manual or any unauthorized modification to the device.

***The Robin iBOLT was designed for outdoor use and it is intended for professional application only. It is not for household use.***

***Please note that the rules and regulations stated in this manual may vary depending on the country of use the device . Always refer to local guidelines and legal requirements.***

## **1. Safety instructions and operating determinations**

**The operator of the device has to read all safety instructions and warnings stated in the user manual before operating the device.**

### **CAUTION!**

**Disconnect the device from mains before removing any cover of the device. With a high voltage you can suffer a dangerous electric shock when touching alive wires and electrical parts under covers!**

**This device falls under protection class I. Therefore this device has to be connected to a mains socket outlet with a protective earthing connection.**

**The light source of the device is made of laser diodes. Risk of eye injury. Do not look straight at the light source during operation. The intense light beam may damage your eyes. Sensitive persons may suffer an epileptic shock.**



**CLASS 1  
Laser product**

**CAUTION! Risk group 3, RG-3**

**Avoid looking directly into the light source.**



**CAUTION !  
Risk group 3**

**Do not view the light output with optical instruments or any device that may concentrate the beam.**

**The device complies with the standards:**

***EN 60825-1:2014 – Safety of laser product.***

- The product includes a light source based on laser diodes. It complies with the requirements of clause 4.4 of the laser safety standard IEC 60825-1:2014 (3rd edition).
- It is a "laser product designed to function as conventional luminaire" as defined in the clause 4.4 itself, so it is classified as CLASS 1 LASER PRODUCT according to IEC 60825-1:2014.

**IEC 62471- Photobiological Safety of Lamps and Lamp Systems.**

- Photobiological risk classification is performed according to the standard IEC 62471:2006, for conventional luminaires, using 2013 ICNIRP exposure limits, resulting in a Risk Group 3 (RG3).

**EN 60598-2-17 Requirements for stage, television, film and photographic studio luminaires.**

**UL 1573 - Standard for Stage and Studio Luminaires and Connector Strip**

**The user or service worker must not remove covers of the laser source!  
The user or service worker must not do any servis works on the laser source!**

Operators shall control access to the beam within the hazard distance or install the devicet at the height that will prevent spectators' eyes from being within the hazard distance.

Laser radiation levels in excess of the limits of Class I shall not be permitted at any point less than 3.0 meters above any surface upon which persons other than operators, performers, or employees are permitted to stand or 2.5 meters below or in lateral separation from any place where such persons are permitted to be. Operators, performers, and employees shall not be required or allowed to view radiation above the limits of Class I or be exposed to radiation above Class IIIa.

All laser light shows shall be under the direct and personal control of trained, competent operator(s). The operator(s) shall: (1) Be an employee of the variance holder who will be responsible for the training and the conduct of the operator; (2) Be located where all beam paths can be directly observed at all times; (3) Immediately terminate the emission of light show radiation in the event of any unsafe condition; or for outdoor shows, upon request by any air traffic control officials.

**Use of controls or adjustments or performance of procedures other than those specified herein may result in hazardous radiation exposure!**

## **SKY MODE**

**The device operated in the SKY MODE must not be pointed at any time and any circumstances to the spectators or to the spaces where people can appear.**

**The light output from the device in the SKY MODE must not aim**

- to the area where people or animals can occur
- to the populated area
- to the area where a risk of glare of drivers or pilots can appear
- to the area where optical security systems are installed
- to the area where reflective elements are installed (e.g. mirrors, panels, etc)

**SKY MODE - Retinal thermal hazard distance: min. 80m**

**SKY MODE - Thermal hazard distance from illuminated surfaces: min. 45m**

## **STAGE MODE**

### Retinal thermal hazard distance

Retinal thermal hazard distance depends on setting on the channel Safety control (channel 8, DMX range of 45-58).

| <u>Stage mode</u>                  | <u>Retinal thermal hazard</u> |
|------------------------------------|-------------------------------|
| Stage mode safe distance from 10 m | 0 - 10 m                      |
| Stage mode safe distance from 20 m | 0 - 20 m                      |
| Stage mode safe distance from 30 m | 0 - 30 m                      |
| Stage mode safe distance from 40 m | 0 - 40 m                      |
| Stage mode safe distance from 50 m | 0 - 50 m                      |
| Stage mode safe distance from 60 m | 0 - 60 m                      |
| Stage mode safe distance from 70 m | 0 - 70 m                      |

## STAGE MODE

### Thermal hazard distance from illuminated surfaces

Thermal hazard distance from illuminated surfaces depends on setting on the channel Safety control (channel 8, DMX range of 45-58).

| <u>Stage mode</u>                  | <u>Min. distance from illuminated surfaces</u> |
|------------------------------------|--|
| Stage mode safe distance from 10 m | 7 m  |
| Stage mode safe distance from 20 m | 16 m   |
| Stage mode safe distance from 30 m | 22 m   |
| Stage mode safe distance from 40 m | 31 m   |
| Stage mode safe distance from 50 m | 35 m   |
| Stage mode safe distance from 60 m | 38 m   |
| Stage mode safe distance from 70 m | 41 m   |

Always keep transparent covers of LIDAR sensors on the device head clean and do not block them with any objects.

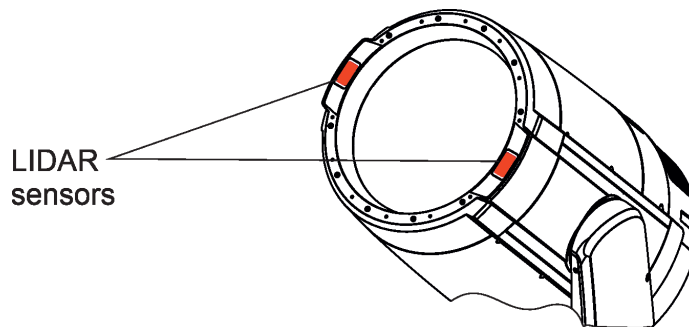

### **Warning!**

If some obstacle (person, object) appears in the light beam in distance to 5 metres from the device, its light output is automatically closed. It is a default setting of the device. Change of the safety function can be done by means of DMX channel 8 (Safety control, Lidar distance setting). The safety function applies to both operating modes- Stage and Sky.

**The LIDAR sensors works only in a clean environment, they do not work in smoky or rainy environment or in environment polluted in another way (confetti, pyrotechnical effects, etc.)!**

Service of the device has to be performed by trained and authorized personnel only.

The device has to be securely mounted on the truss to prevent its unintended movement or misalignment.

Make sure that the available voltage is not higher than stated on the bottom panel of the device. This device should be operated only from the type of power source indicated on the marking label. If you are not sure of the type of power supplied, consult your authorized distributor or local power company.

Always disconnect the device from AC power before cleaning, removing or servicing any part of the device.

The power plug has to be accessible after installing the device. Do not overload wall outlets and extension cords as this can result in fire or electric shock.

Do not allow anything to rest on the power cable. Do not locate this device where the power cable may be damaged by persons walking on it. Make sure that the power cable is never crimped or damaged by sharp edges.

Do not connect this device to a dimmer pack.

This device does not contain an ON/OFF switch. Always disconnect the power cable from mains to completely remove power from the device when not in use or before cleaning or servicing the device.

The device must be placed so that any flammable materials are at least 0.5 meters (20") from every point on the surface of the luminaire.

The device housing and front glass cover never must be covered with cloth or other materials during its operation. Do not block fans or fans ventilation slots with any object. Fans and ventilation slots must remain clean.

The device becomes very hot during operation. Do not touch the device housing bare hands during its operation. Allow the device to cool approximately 40 minutes prior to manipulate with it.

Only operate the device after having checked that the housing is firmly closed and all screws are tightly fastened.

Always use a safety wire for overhead installation.

Make sure that the area below the installation place is blocked when rigging, derigging or servicing the device. The maximum ambient temperature 50° must never be exceeded.

**The iBOLT is heavy, two persons should manipulate with it. During manipulation, the moving head must be secured against movement by means of the pan and tilt locks!**

Operate the device only after having familiarized with its functions. Do not permit operation by persons not qualified for operating the device.

For replacement of the main fuse use fuse of the same type and rating only.

The product (covers and cables) must not be exposed to a high frequency electromagnetic field higher than 3V/m.

Immunity of the equipment is designed according to the standard EN 55035 Electromagnetic compatibility of multimedia equipment - Immunity requirements.

Emission of the equipment complies with the standard EN55032 Electromagnetic compatibility of multimedia equipment – Emission Requirements according to class B.

Contains FCC ID: 2A6PL-DMXRDMRW001

Contains IC: 29573-DMXRDMRW001

This device complies with part 15 of the FCC Rules. Operation is subject to the following two conditions:

(1) This device may not cause harmful interference, and (2) this device must accept any interference received, including interference that may cause undesired operation.

Changes or modifications not expressly approved by the party responsible for compliance could void the user's authority to operate the equipment.

The [Device] wireless operation is safe and complies to RF Exposure requirements

This equipment has been tested and found to comply with the limits for a Class B digital device, pursuant to part 15 of the FCC Rules. These limits are designed to provide reasonable protection against harmful interference in a residential installation. This equipment generates, uses and can radiate radio frequency energy and, if not installed and used in accordance with the instructions, may cause harmful interference to radio communications. However, there is no guarantee that interference will not occur in a particular installation. If this equipment does cause harmful interference to radio or television reception, which can be determined by turning the equipment off and on, the user is encouraged to try to correct the interference by one or more of the following measures:

- Reorient or relocate the receiving antenna.
- Increase the separation between the equipment and receiver.
- Connect the equipment into an outlet on a circuit different from that to which the receiver is connected.
- Consult the dealer or an experienced radio/TV technician for help.

**CAUTION!**

The front glass cover has to be replaced when it is obviously damaged, e. g. due to cracks or deep scratches!

**CAUTION!**

To avoid damage of the internal parts of the device head, never let the sunlight (or other light source) lights directly to the front glass cover, even when the device is not in operation !

The fixture must not come into contact with sea water (salt water). Damages or corrosion issues resulting from salt water will void the manufactures warranty and will not be subject to any warranty claims or repairs.

Please use only an original ROBE packaging (paper box, loader case or foam shell) for transporting the device, otherwise potential damage of the device during its transport will not subject to warranty.

**When the new device (device directly from the manufacturer) is switched on for the first time, the light output from the device is disabled (dimmer is locked).**

Stage mode

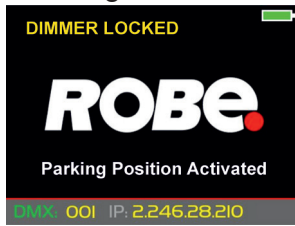

Sky mode

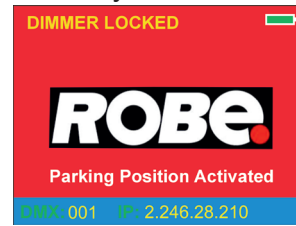

**Enabling light output from the device can be done only in two ways:**

1. **DMX console** - send the following values on the two channels at the same time (stay in values at least 3 seconds):

Channel 7 (Power/Special functions): 226 DMX  
Channel 8 (Safety control): 39-40 DMX

2. **Display menu** - enter the password 2479 in the menu "Manual Effect Control"

(tab  -->item "Manual Effect Control")

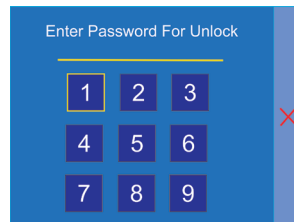

**By enabling light output from the device, the operator confirms that they have read and understands all safety information stated in the user manual.**

The operator of this device must not provide information about enabling light output from the device to a person who is not familiar with the user manual and the safety regulations contained therein.

The operator of this device must not pass on control of this device with activated light output to a person who is not familiar with the user manual and the safety regulations contained therein.

**Note:**

- 1. If the light output from the device is deactivated by DMX command on the channel 8 (37-38 DMX), one of the light enabling methods stated above must be used to enable light output again.**
- 2. If the light output from the device is deactivated by DMX command on the channel 8 (37-38 DMX) and the device is switched off and on, one of the light enabling methods stated above must be used to enable light output from the device.**

**Remove the protective lens cover from the front lens before switching the Robin iBOLT on!**



## 2. Loader case manipulation

The iBolt loader case consist of three parts.

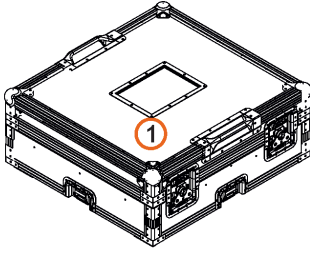

1 - Top part of the loader case with compartment for accessories

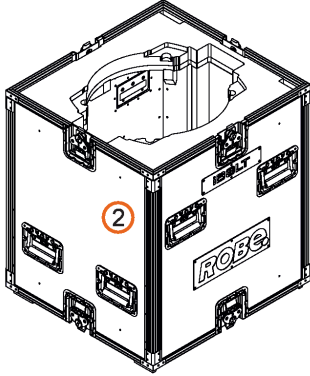

2 - Middle part of the loader case with foam shell

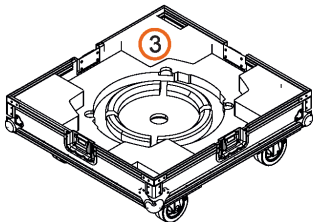

3 - Bottom part of the loader case with wheels

The iBolt can be placed in the loader case in two ways.

### Fixture base down

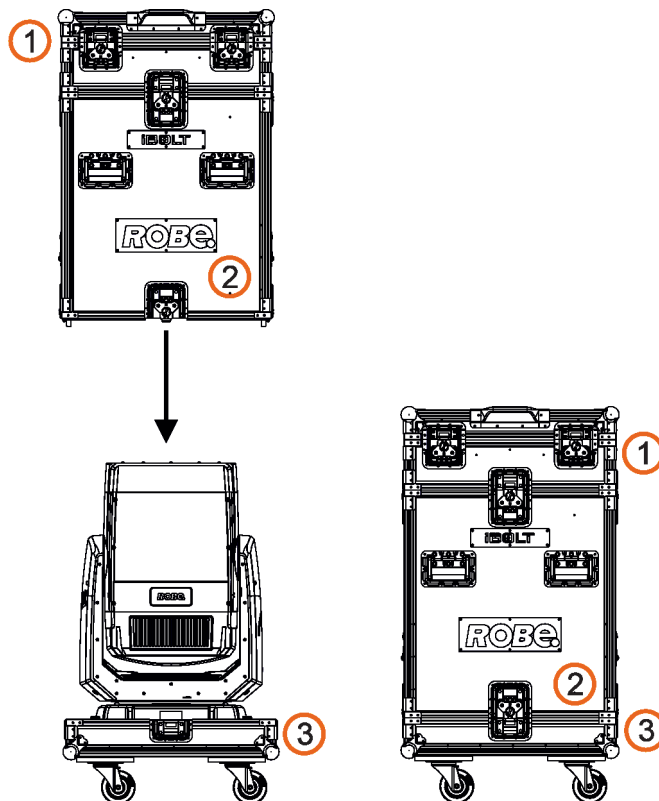

Place the iBolt on the bottom part (3) of the loader case and slide the middle part (2) with the top part (1) on the iBolt.

## Fixture base up

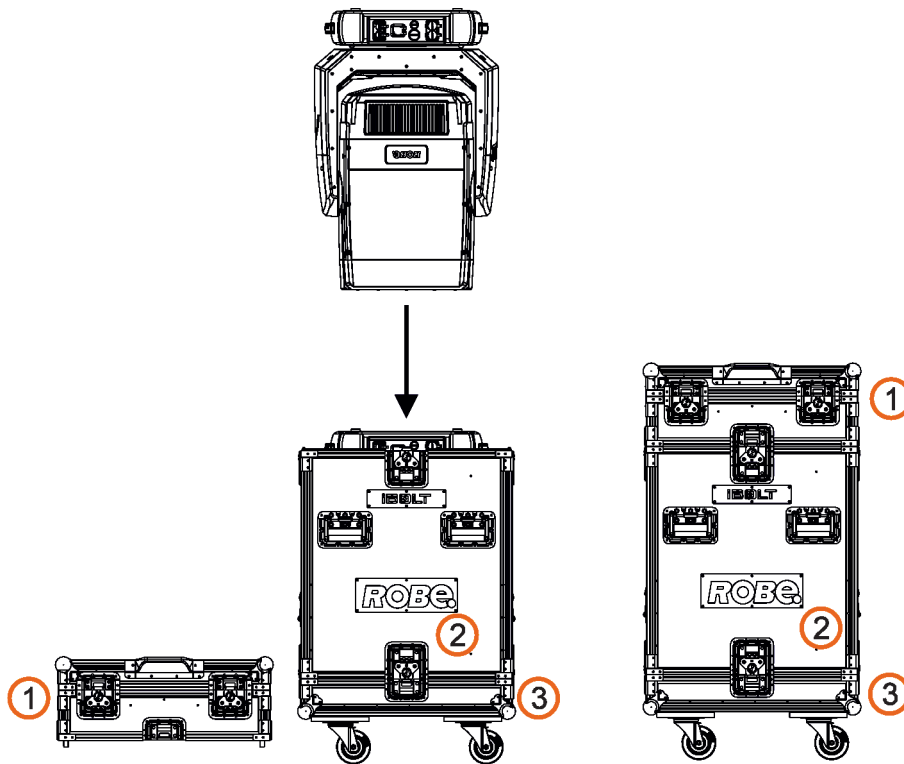

Remove the top part (1) of the loader case and insert the iBolt into the middle part (2) of the loader case and close the case by the top part (1).

**The Robin iBOLT is heavy, two persons should manipulate with it.  
During manipulation, the moving head must be secured against movement  
by means of the pan and tilt locks!**

**All parts of the loader case have to be properly locked before handling with the loader case!**

**Never place the iBolt on the bottom part (3) of the loader case without the middle part (2). There is a risk of the iBolt tipping over!**

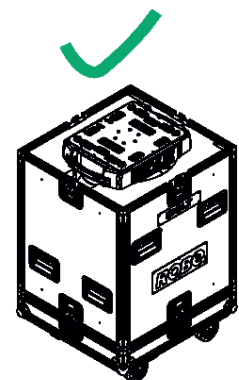
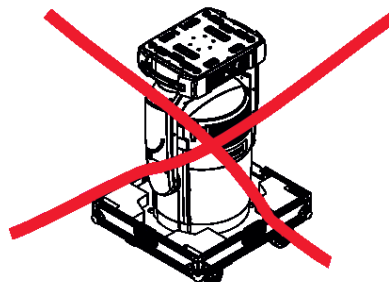
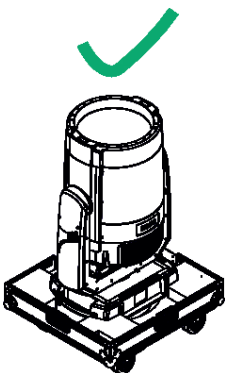

### 3. Fixture exterior view

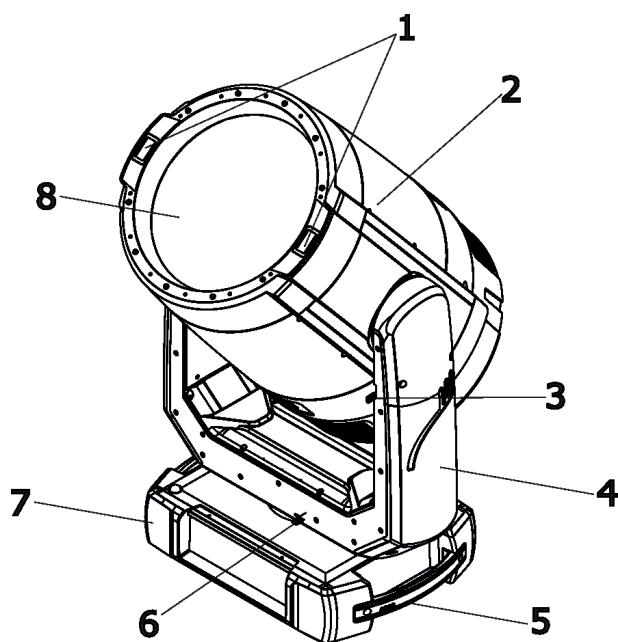

- 1 - Transparent covers of LIDARS
- 2 - Head
- 3 - Tilt lock
- 4 - Arm
- 5 - Handle
- 6 - Pan lock
- 7 - Base
- 8 - Front lens

The head has to be locked for transportation - the tilt lock latch (3) and the pan lock latch (6) have to be in the locked positions. To unlock the head, move these latches to unlock position before operating the fixture.

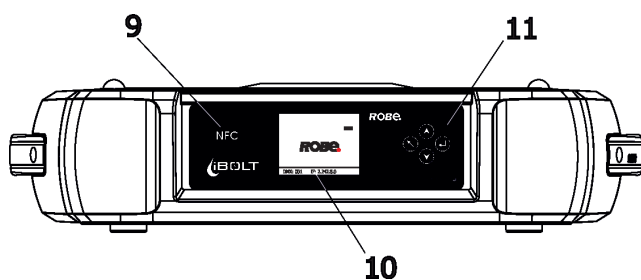

#### Front panel of the base

- 9 - NFC point
- 10 - Display
- 11 - Control buttons

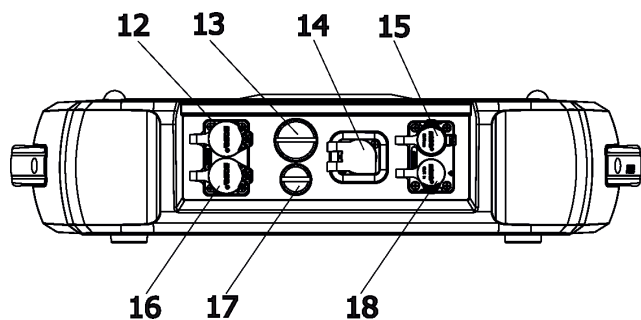

#### Rear panel of the base

- 12 - Ethernet out (RJ45)
- 13 - Cover of battery holder
- 14 - Power
- 15 - DMX out (5-pin XLR)
- 16 - Ethernet In (RJ45)
- 17 - Cover of fuse holder
- 18 - DMX in (5-pin XLR)

## 4. Installation



**Fixtures must be installed by a qualified electrician in accordance with all national and local electrical and construction codes and regulations.**

**The Robin iBOLT's panel connectors are dust and water protected according to IP 65 by mating with related cable connectors. They cannot stay disconnected outdoor.**

**All unused panel connectors have to be sealed by the rubber caps.**

**Visually check panel connectors on accidental water leaks before connecting related cable connectors.**

**If some water will appear in panel connectors, do not connect cable connectors, especially power!**

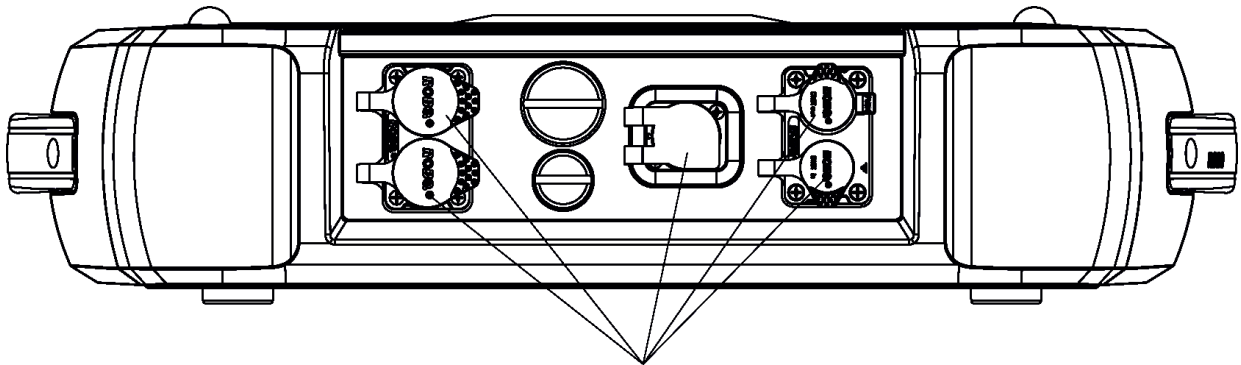

The rubber caps have to be placed on unused connectors.

**The fixture must not come into contact with sea water (salt water).**

## 4.1 Connection to the mains

To apply power, first check that the head pan and tilt locks are released.

***For protection from electric shock, the fixture must be earthed!  
The fixture has to be connected to an electric outlet which is equipped with  
a residual-current device (residual-current circuit breaker)!***

Wiring and connection work must be carried out by a qualified electrician.

The Robin iBOLT is equipped with auto-switching power supply that automatically adjusts to any 50-60Hz AC power source from 100-240 Volts.

Mains cable powerCON TRUE1 In/open ended is enclosed to the fixture. We recommend to install cord end-sleeves 1.5 x 8 (cross section in mm<sup>2</sup> x length in mm) on the cords of the mains cable. If you need to install a power plug on the mains cable to allow connection to power outlets, install a grounding-type (earthed) plug, following the plug manufacturer's instructions. If you have any doubts about proper installation, consult a qualified electrician. Connection to mains has to keep IP 65 protection rating.

| Core (EU)    | Core (US) | Connection | Plug Terminal Marking |
|--------------|-----------|------------|-----------------------|
| Brown        | Black     | Live       | L                     |
| Light blue   | White     | Neutral    | N                     |
| Yellow/Green | Green     | Earth      | PE/GND                |

This device falls under class one and must be earthed (grounded).

Ensure all connections and the power plug on the cable are properly sealed.

## 4.2 Replacing rotating gobos

**Unplug the fixture from mains before replacing the gobos!  
Do not replace gobos in a damp environment (e.g. rain, snowfall)!  
Do not remove fixture covers in smoky or particularly dirty  
environment (e.g. with fog machines).**

1. Close a light output of the fixture and allow the fixture to cool about 40 minutes.
2. Move the fixture head to the position as shown on the picture below (the tilt lock has to be on the same side as the display) to determine which top cover of the head has to be removed. Remove the top cover of the head by unscrewing 6 hex socket head screws M5x16 on the cover to get access to gobo wheel.

**IMPORTANT:** The fixture head should be uncovered as short time as possible (about 1-2 hours depending on air humidity) otherwise silica gel in the small boxes in the fixture head may become damp.

If you have removed head cover and you need to interrupt your work for long time (hours, days), we recommend to place the head cover on the head and fasten it provisionally by means of two screws, next possibility is unscrewing small boxes with silica gel from the head and put it to a sealed container with limited access of air (e.g. sealed plastic bag).

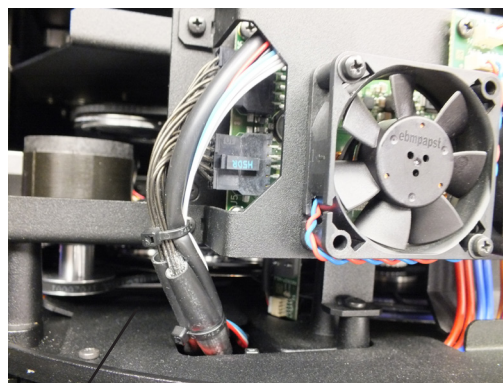
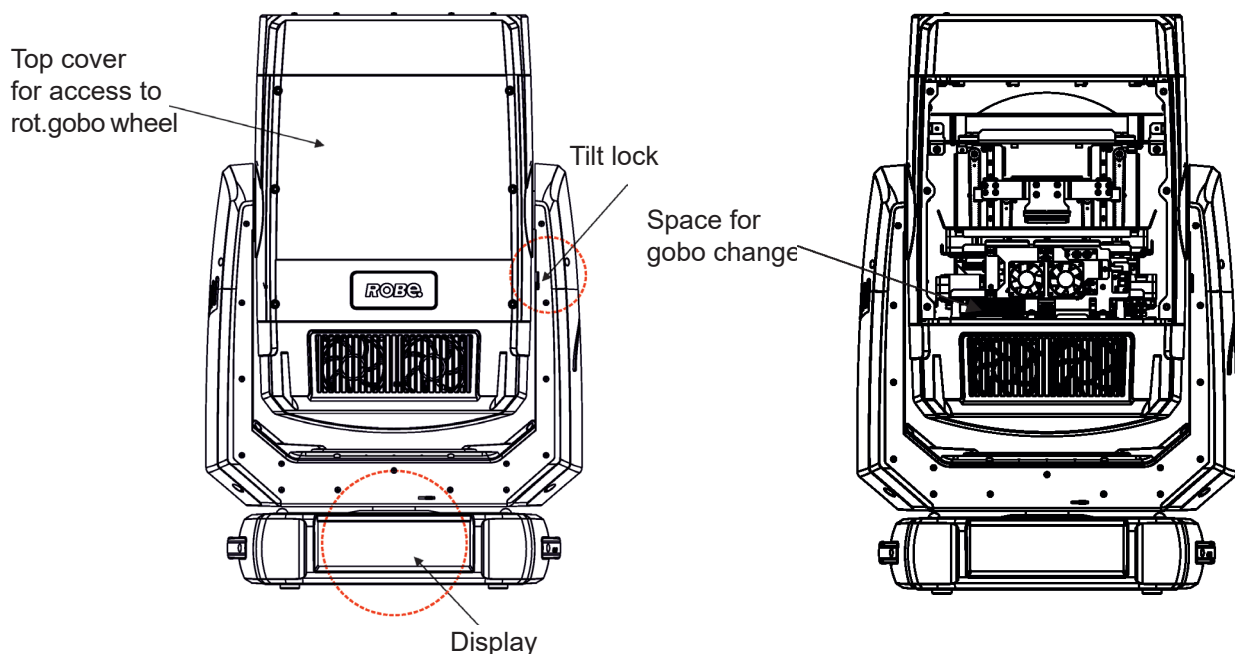

Space for gobo change

3. Connect the fixture to mains and close shutter and dimmer. Go to the tab "Service", select the menu "Adjust DMX values " and move the fixture head to the position which is suitable for changing rot. gobos.
4. Escape from the menu "Adjust DMX values " and go to the menu " Rotating Gobos Change" in the same tab, select menu Gobo Carousel and enter the menu.
5. Select a gobo (G1-Mg, G2, G3, G4, G5... G9 ) which you wish to replace. The selected gobo will move to the accessible position for its changing.

Note: "G1-Mg" means the gobo holder with a magnet.

6. Check that the position point (7) on the gobo holder aims exactly to the toothlike projection (8) on the edge of the rotating gobo wheel. If not, go to the option "Gobo Offset" and adjust the position point (7) exactly opposite of the toothlike projection (8).  
 Note: The magnet on the gobo holder substitutes the position point (7).  
 Adjusted value in the "Gobo Offset" is valid for all gobos on the gobo carousel.

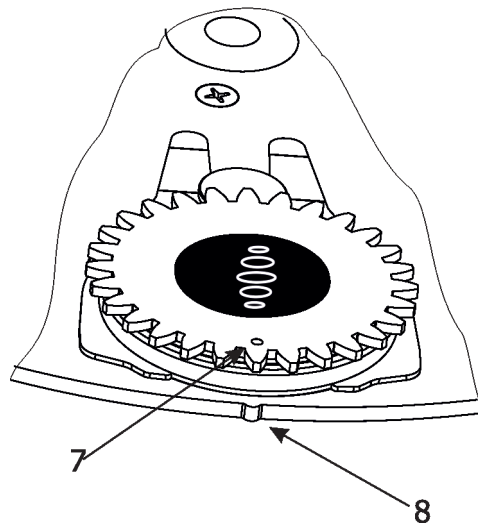

7. Gently pull the gobo holder (4) up from the rotation gobo wheel (3). Use suitable long-nose pliers for pulling the gobo holder from the rotating gobo wheel.

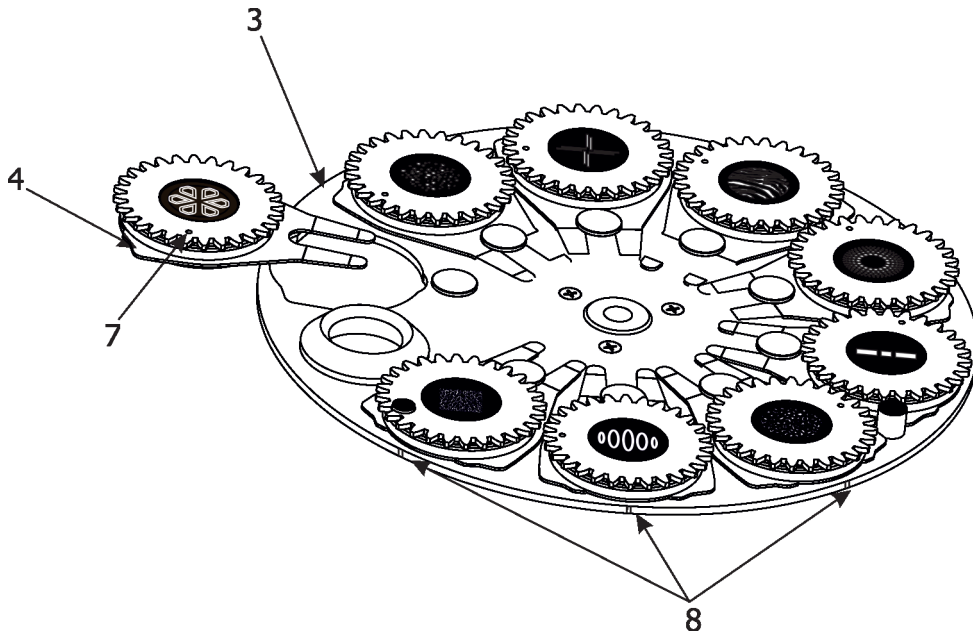

8. Carefully remove the spring lock (5) and the gobo (6) from the gobo holder (4) by pushing to the gobo from side of toothed wheel. Do not touch the glass gobo bare fingers - use a suitable gloves.  
 9. Insert the new gobo (glossy side towards the light source). Gobo has to be oriented according to axis of the gobo holder and the position point (7). Orientation of gobos shows a picture on the following page.  
 10. Insert the spring lock (5) to secure the gobo (6) in the gobo holder (4).

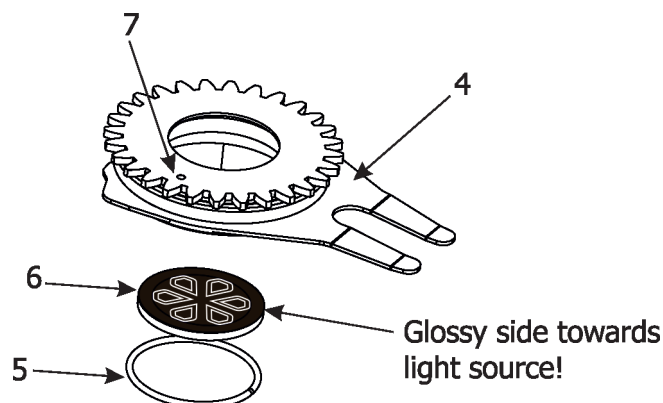

**Use only gobos intended for the Robin iBOLT.  
Do not try to use gobos from the Robin Pointe.**

Orientation of gobos in the gobo holders:

**View from side of gobo inserting**

(Points and magnet showed for orientation only, in fact they are on the opposite side of the gobo holder!)

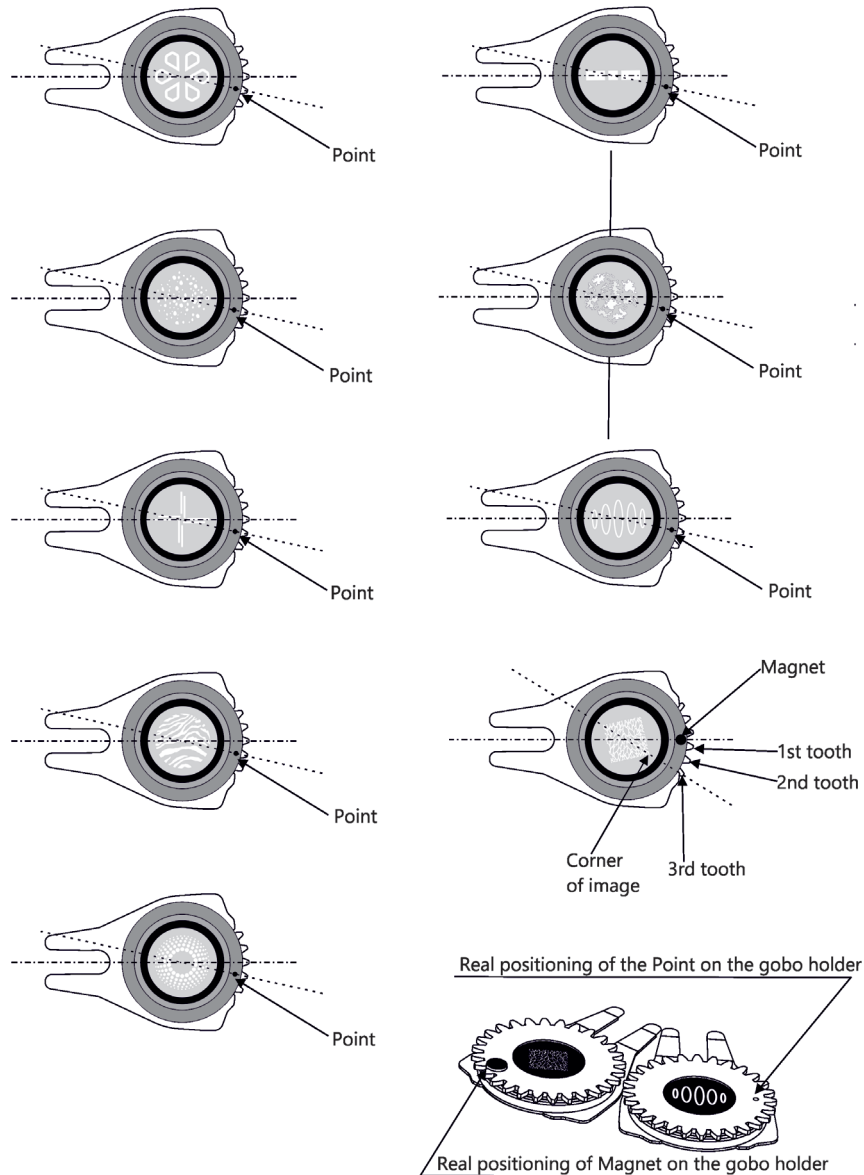

11. Insert the gobo holder (4) back into rotating gobo wheel (3) in this way, that its position point (7) has to aimed at a small toothlike projection (8) on the edge of the rotating gobo wheel. On gobo position with magnet, align the magnet with small toothlike mark (8).

**Important!** When inserting the gobo holder back to the rotating gobo wheel, one of the adjacent gobo has to be oriented according to the same rule, it means that its position point (7) has to aimed at the toothlike projection (8) on the edge of the rotating gobo wheel.

12. After replacing desired gobos, connect the fixture to mains and light on changed gobos (gobo holders) with max. intensity (Shutter open /254 DMX, Dimmer open /255 DMX) approximately 10 minutes per each changed gobo position to evaporate potential grease from gobo holders and gobos.

**Zoom must be set at max. diameter /0 DMX and Focus must be set in range of 0-160 DMX!**

During this procedure, the fixture head has to be in a horizontal position without top cover (side of fixture head without top cover has to be up) and illuminated gobo has to rotate.

**No person can occur in the light beam of the fixture during the procedure!**

Note: this step you can leave out if you use original gobo holders from the fixture and you sure that new glass gobos are clean.



13. Switch the fixture off, place the head cover back on the fixture and screw it by means of the six hex socket head screws M5x16. Keep required tightening torque as stated in the chapter Maintenance. Do not forget to connect grounding wire between chassis and head cover.
14. Connect the fixture to the mains.
15. Use the menu Service to calibrate replaced gobo (Service -> Calibration -> Calibrate effects -> R. Gobo Index 1....9 ).
16. **Run the procedure Pressure Test (tab Service -->Pressure Test).**

### 4.3 Rigging the fixture

A structure intended for installation of the fixture(s) must safely hold weight of the fixture(s) placed on it. The structure has to be certificated to the purpose.

The fixture (fixtures) must be installed in accordance with national and local electrical and construction codes and regulations.

***For overhead installation, the fixture must be always secured with two safety wires that can bear at least 10 times the weight of the fixture each.***

When rigging, derigging or servicing the fixture staying in the area below the installation place, on bridges, under high working places and other endangered areas is forbidden.

The operator has to make sure that safety relating and machine technical installations are approved by an expert before taking into operation for the first time and after changes before taking into operation another time.

The operator has to make sure that safety relating and machine technical installations are approved by a skilled person once a year.

Allow the fixture to cool for 40 minutes before handling.

The fixture should be installed outside areas where persons may walk by or be seated.

IMPORTANT! OVERHEAD RIGGING REQUIRES EXTENSIVE EXPERIENCE, including calculating working load limits, installation material being used, and periodic safety inspection of all installation material and the projector. If you lack these qualifications, do not attempt the installation yourself, but use a help of professional companies.

CAUTION: Fixtures may cause severe injuries when crashing down! If you have doubts concerning the safety of a possible installation, do not install the fixture!

The fixture has to be installed out of the reach of public.

The fixture must never be fixed swinging freely in the room.

***Danger of fire !  
When installing the device, make sure there is no highly inflammable material (decoration articles, etc.) in a distance of min. 0.5 m.***

***CAUTION!  
Use 2 appropriate clamps to rig the fixture on the truss.  
Follow the instructions mentioned at the bottom of the base.  
Make sure that the device is fixed properly! Ensure that the structure (truss) to which you are attaching the fixtures is secure.***

The fixture can be placed directly on the stage floor or rigged on a truss without altering its operation characteristics .

For securing the fixture to the truss, install two safety wires which can hold at least 10 times the weight of the fixture each. Use only safety wires with a snap hook with screw lock gate.

## Omega holders points

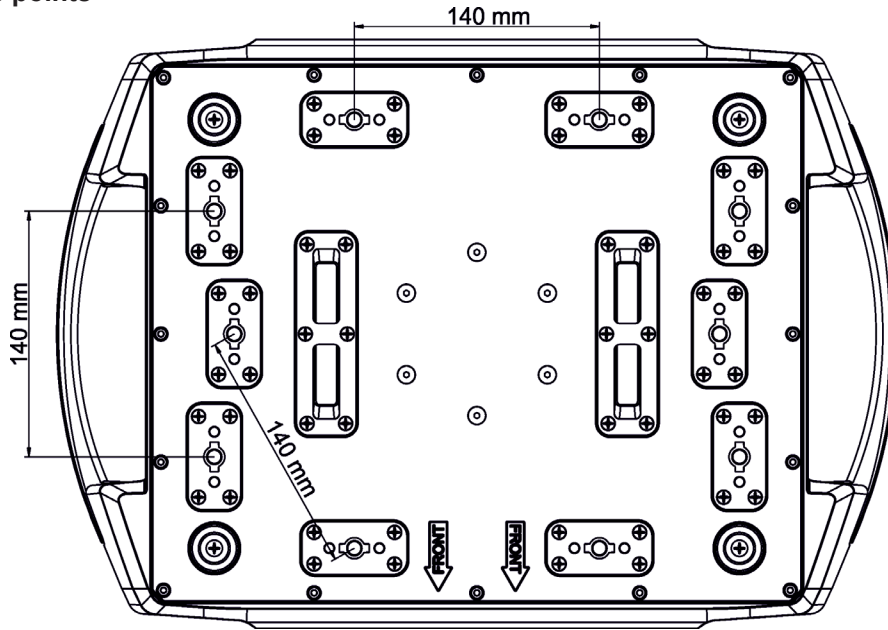

## Truss installation

1. Bolt each clamp (1) to the Omega adaptor (2) with M12 bolt and lock nut through the hole in the adaptor.
2. Fasten the Omega adaptors to the bottom of the base by inserting both quick-lock fasteners (3) into the holes of the base and tighten fully clockwise.
3. Clamp the fixture on a truss (6) and tighten the rigging clamps (1).
4. Pull one safety wire (4) around the truss (6) and through the handle (7) and lock the snap hook of the safety wire in the attachment point (5). Pull the second safety wire (4) around the truss (6) and through the second handle (7) and lock the snap hook of the safety wire in the attachment point (5) as shown on the picture below. Use safety wires of a suitable length that maximum fall of the fixture will be 20 cm.

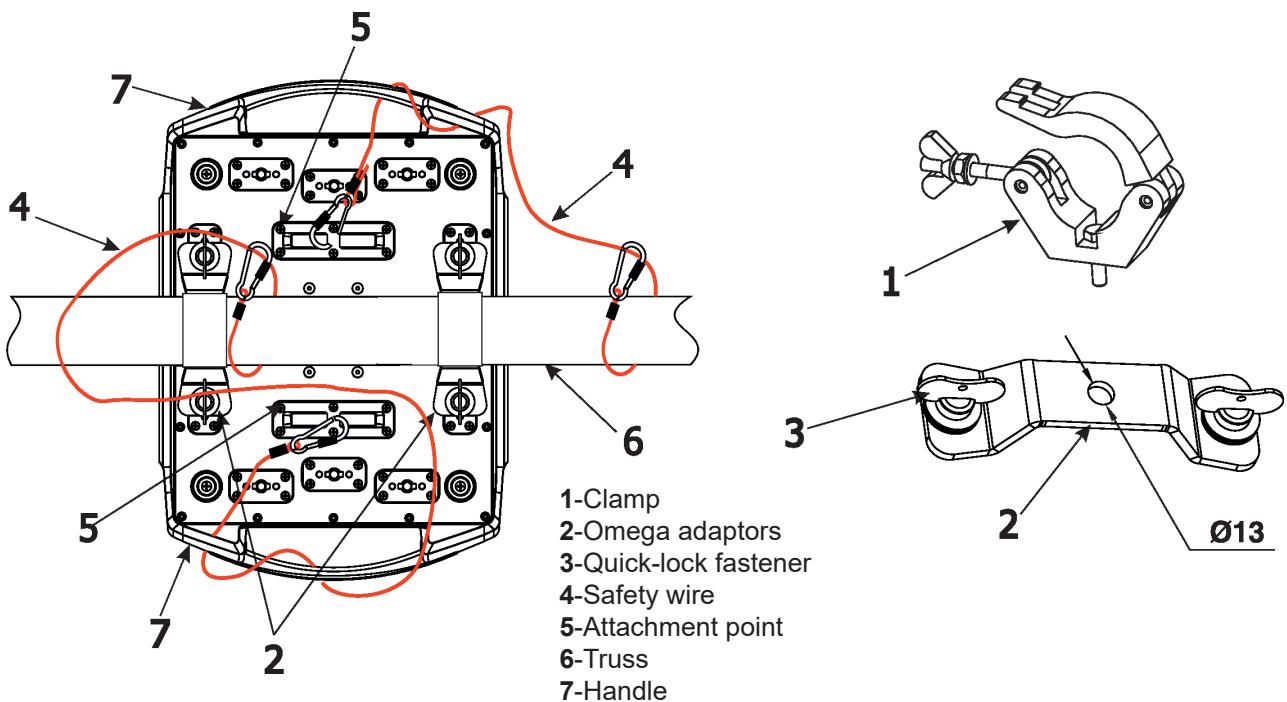

### Note:

Surface corrosion of the Omega adaptors may occur, especially if this fixture has been used outdoors. Surface corrosion will not affect the safety of the Omega adaptors. Omega adaptors corrosion is not covered by the warranty.

**When installing fixtures side-by-side,  
 avoid illuminating one fixture with another!**

**DANGER TO LIFE!**  
**Before taking into operation for the first time, the installation has to be approved by an expert!**

Allowed installation positions of the Robin iBOLT

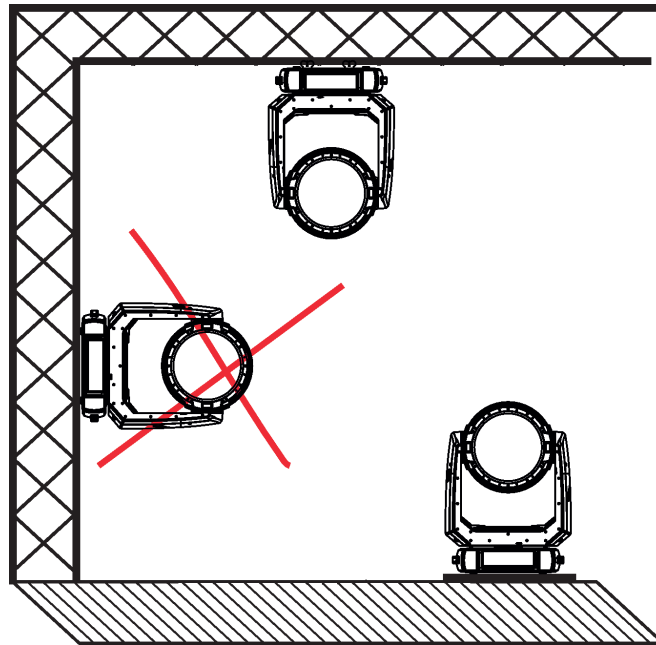

Note for open-air installation: if the fixture has to stand on the ground, min. distance of 4" (10cm) between the fixture base and the ground has to be kept.

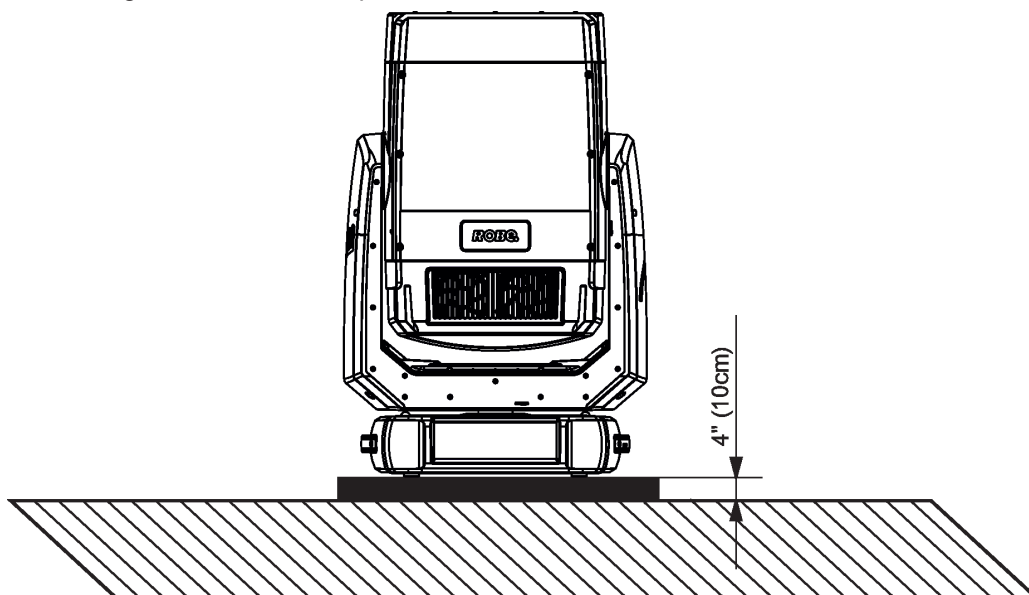

**In order to protect the internal parts of the head from the sun, the function PARKING POSITION must be switched ON before switching the fixture off.**

The **Parking position** function is located on the Power/Special functions channel (126-129 DMX). If the function is on, the fixture will automatically detect via G-sensor whether the fixture is on the floor or hangs on the truss and moves the pan and tilt to the position (including movement of zoom to the front part of the head) in which the head will always face down. Owing this position of the fixture head, there is not chance to burn internal parts of the head by the sun light.

Note: another function relating to the Parking position is **Aut Parking Pos.** in the display menu (tab Personality-->Aut Parking Pos.) When this option is enabled, the fixture will automatically move to the Parking position whenever it is powered on and a DMX signal is missing. Once a DMX signal is present, the Parking position will be automatically disabled.

## 4.4 DMX-512 connection

The fixture is equipped with 5-pin XLR sockets for DMX input and output. Use a shielded twisted-pair cable designed for RS-485 and 5-pin XLR-plugs and connectors in order to connect the controller with the fixture or one fixture with another.

### DMX output

#### XLR socket (female)

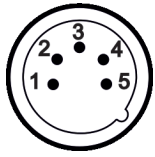

- 1 - Shield
- 2 - Signal (-)
- 3 - Signal (+)
- 4 - Not connected
- 5 - Not connected

### DMX input

#### XLR socket (male)

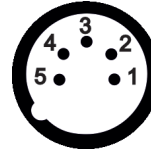

- 1 - Shield
- 2 - Signal (-)
- 3 - Signal (+)
- 4 - Not connected
- 5 - Not connected

If you are using the standard DMX controllers, you can connect the DMX output of the controller directly with the DMX input of the first fixture in the DMX chain. If you wish to connect DMX controllers with other XLR outputs, you need to use adaptor cables.

### Building a serial DMX chain:

Connect the DMX output of the first fixture in the DMX chain with the DMX input of the next fixture. Always connect one output with the input of the next fixture until all fixtures are connected. Up to 32 fixtures can be connected.

**Caution:** At the last fixture, the DMX cable has to be terminated with a terminator. Solder a 120  $\Omega$  resistor between Signal (-) and Signal (+) into a 5-pin XLR plug and plug it in the DMX output of the last fixture.

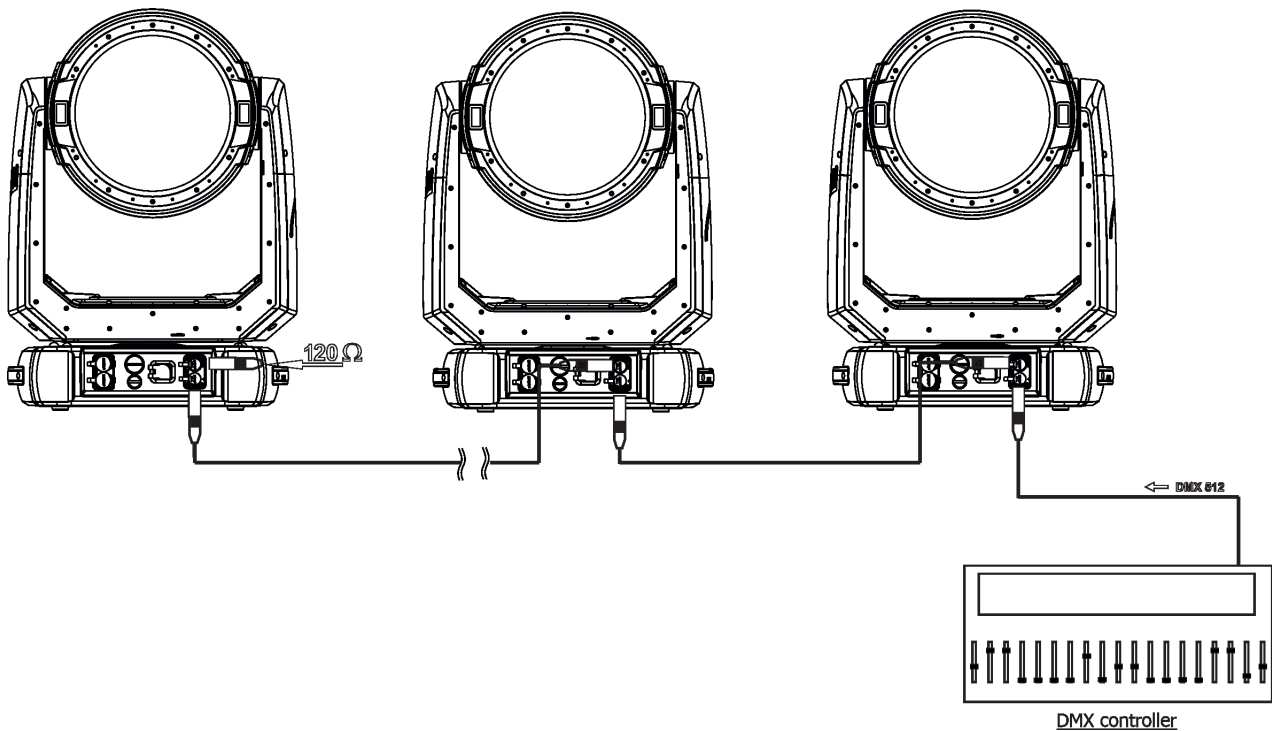

## 4.5 Ethernet connection

The fixtures on a data link are connected to the Ethernet with appropriate communication protocol (e.g. Art-Net). The control software running on your PC (or light console) has to support Art-Net protocol. Art-Net communication protocol is a 10 Base T Ethernet protocol based on the TCP/IP. Its purpose is to allow transfer of large amounts of DMX 512 data over a wide area using standard network technology.

**IP address** is the Internet protocol address. The IP uniquely identifies any node (fixture) on a network.  
**The Universe** is a single DMX 512 frame of 512 channels.

The Robin iBOLT is equipped with 8-pin RJ-45 sockets for Ethernet connection. Use a network cable category 5 (with four “twisted” wire pairs) and standard RJ-45 plugs in order to connect the fixture to the network.

RJ-45 socket (front view):



- |                  |                  |
|------------------|------------------|
| 1- TD+           | 5- Not connected |
| 2- TD-           | 6- RX-           |
| 3- RX+           | 7- Not connected |
| 4- Not connected | 8- Not connected |

RJ-45 plug (front view):



Patch cables that connect fixtures to the hubs or LAN sockets are wired 1:1, that is, pins with the same numbers are connected together:



If only the fixture and the computer are to be interconnected, no hubs or other active components are needed. A cross-cable has to be used:



If the fixture is connected with active Ethernet socket (e.g. switch) the network icon  will appear at the bottom right corner of the screen:

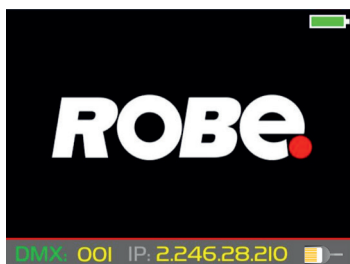

### Ethernet operation

Connect the Ethernet inputs of all fixtures with the Ethernet network. Option “Artnet” (gMal or gMA2 or sACN) has to be selected from “Ethernet Mode” menu at each fixture. Set IP address (002.xxx.xxx.xxx / 010.xxx.xxx.xxx) and the Universe at each fixture.

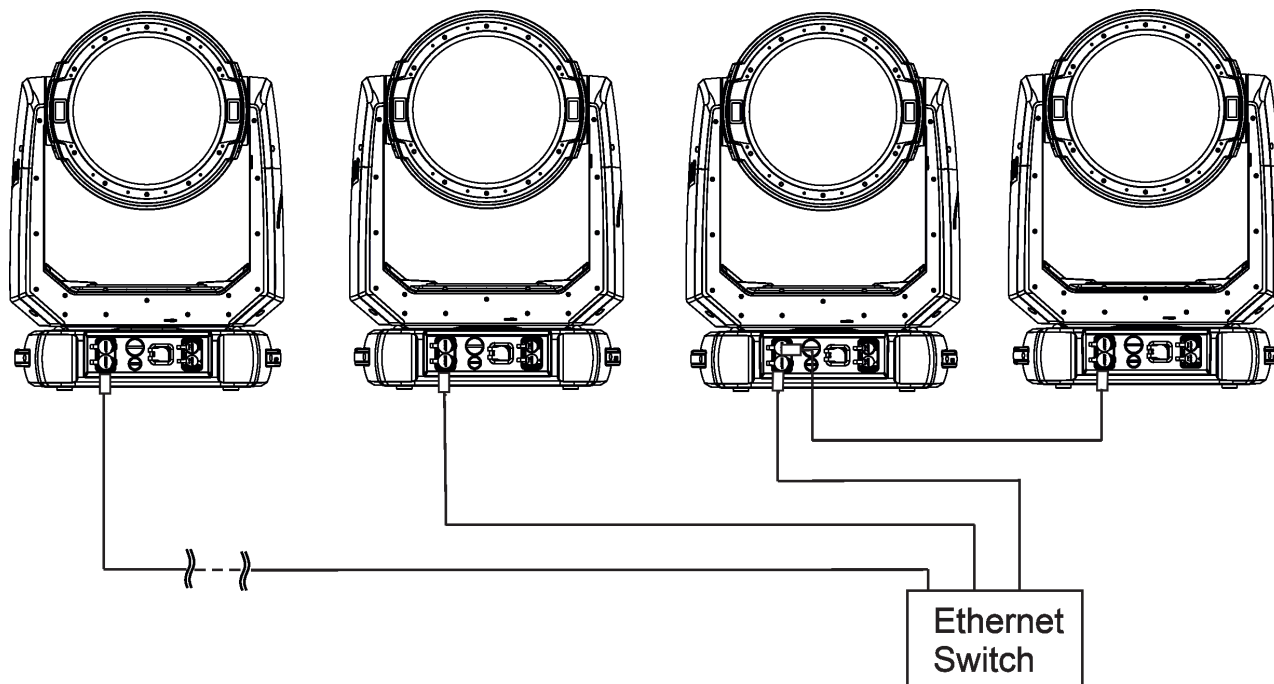

An advised PC setting: IP address: 002.xxx.xxx.xxx (Different from fixture IP addresses)  
 NET mask: 255.0.0.0

The fixture is equipped with Ethernet Pass through switch which sustains Ethernet integrity, when the fixture has no power, it automatically maintains network connectivity.

If you use the Ethernet IN-OUT way for the Ethernet connection, max. 8 fixtures can be connected in the IN-OUT line.

### Ethernet / DMX operation

Option "Artnet" (gMal or gMA2 or sACN) has to be selected from "Ethernet Mode" menu at first fixture.

Option "Ethernet To DMX" has to be selected from the "Ethernet Mode" menu at the first fixture (connected to the Ethernet) in the fixture chain, next fixtures have standard DMX setting.

Connect the Ethernet input of the first fixture in the data chain with the network. Connect the DMX output of this fixture with the input of the next fixture until all fixtures are connected to the DMX chain.

**Caution:** At the last fixture, the DMX chain has to be terminated with a terminator. Solder a 120 Ω resistor between Signal (-) and Signal (+) into a XLR-plug and connect it in the DMX-output of the last fixture.

Example:

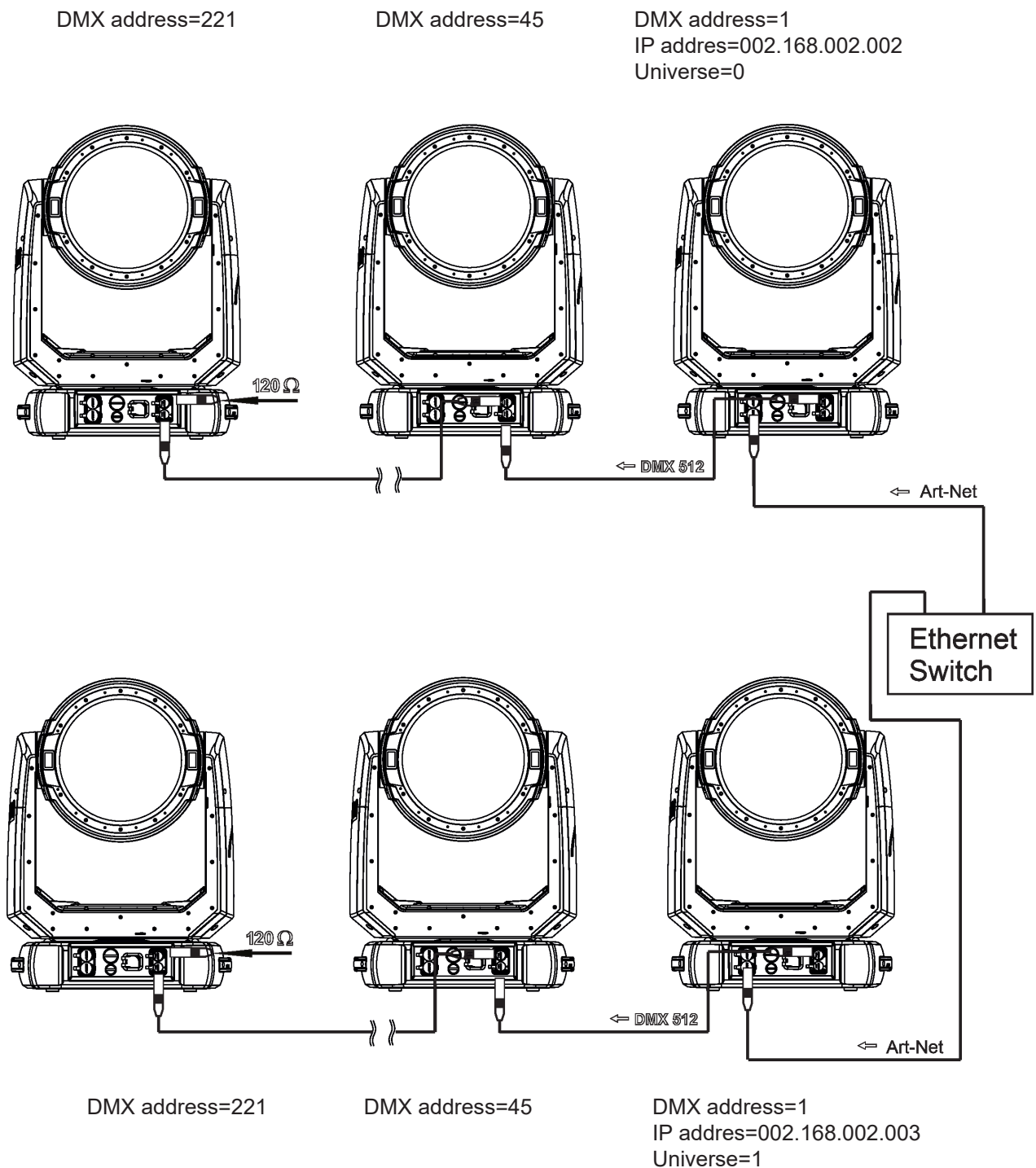

## 4.6 Wireless DMX operation

The ROBE wireless DMX/RDM module has full support for wireless communication protocols at entertainment market. Module is based on well known LumenRadio RF technology, with implemented wire interface for connection with Robe products. RF output for MCX interface antenna as standard output.

The item " Wireless " from the menu "DMX Input" allows you to activate receiving of wireless DMX (Personality--> DMX Input -->Wireless.). First two options from the "DMX Input" menu are stated in DMX chart as well (channel Power/Special functions , range of 2-5 DMX). If DMX input option is changed by DMX command, the change is permanently written into fixture's memory.

**DMX range of 2-5 switching fixture to the wired/wireless operation is active only during first 10 seconds after switching the fixture on.**

After switching the fixture on, the fixture checks both modes of receiving DMX in the following order:

1. For the first five seconds, the fixture receives DMX signal from the wired input. If the Power/Special functions channel is set at some DMX input option, the fixture will receive DMX value according to this option. If DMX input option is set to the wired input , this option is saved and checking procedure is finished. If DMX input option is not set, the fixture continues next 5 seconds in scanning wireless DMX signal-see point 2.

2. For the next 5 seconds the fixture receives wireless DMX signal and again detects if the Power/Special functions channel is set at some DMX input option, if not, the fixture will take option which is set in the fixture menu "DMX Input".

To link the fixture with DMX transmitter.

The fixture can be only linked with the transmitter by running the link procedure at DMX transmitter .

After linking , the level of DMX signal ( 0-100 % ) is displayed in the menu item "Wireless State" (Information -->Wireless State).

To unlink the fixture from DMX transmitter.

The fixture can be unlinked from transmitter via the menu item " Unlink Wireless Adaptor" (Information--> Wireless State --> Unlink Wireless Adaptor).

**Note:** If the option "Wireless In/XLR Out" is selected (Personality--> DMX Input -->Wireless In/XLR Out), the fixture receives wireless DMX and sends the signal to its wired DMX output. The fixture behaves as " Wireless/Wired" adaptor.

Example of connection:

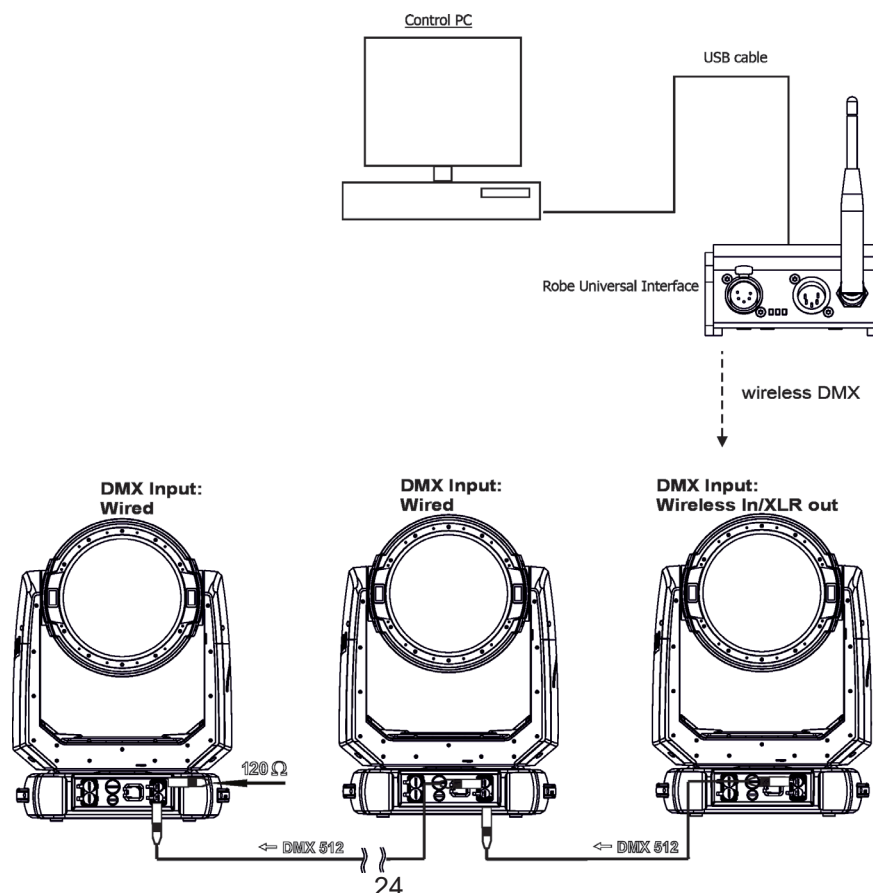



## 4.7 Stage mode and Sky mode

The fixture can be operated in two modes: Sky and Stage. Switching to desired mode can be done by the display menu (tab "Personality", option "Safety Control") or by DMX commands (channel "Safety control"). After switching the fixture off and on, the fixture will stay in last activated mode.

**Important**  
**After setting pan and tilt limits on each fixture for the full intensity zone (Sky mode zone) and the limited intensity zone (Stage mode zone), these limits override the ability to switch modes during operation.**

**STAGE MODE** - the mode is set as a DEFAULT mode in the new iBolt from the factory.

Fixture in the Stage mode- examples of screens.

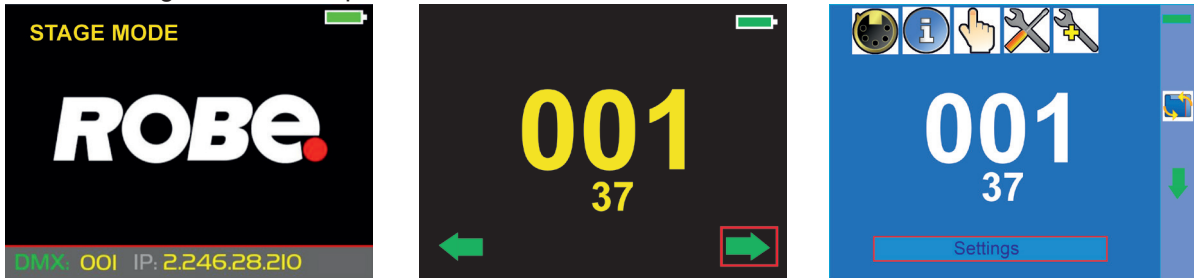

The safe distance with respect to the retinal thermal hazard in this DEFAULT Stage mode is 40 m and more from the fixture. If you need to set another safety distance for retinal thermal hazard in the Stage mode, use the channel 8 (Safety control).

The light output from the fixture in the Stage mode is reduced depending on setting on the channel 8.

### Safety control - channel 8

| DMX value | Function  |
|-----------|---|
| 45-46     | Stage mode safe distance from 10 m                        |
| 47-48     | Stage mode safe distance from 20 m                        |
| 49-50     | Stage mode safe distance from 30 m                        |
| 51-52     | <b>Stage mode safe distance from 40 m - default value</b> |
| 53-54     | Stage mode safe distance from 50 m                        |
| 55-56     | Stage mode safe distance from 60 m                        |
| 57-58     | Stage mode safe distance from 70 m                        |

Example:

45-46 DMX **Stage mode safe distance from 10 m**    47-48 DMX **Stage mode safe distance from 20 m**

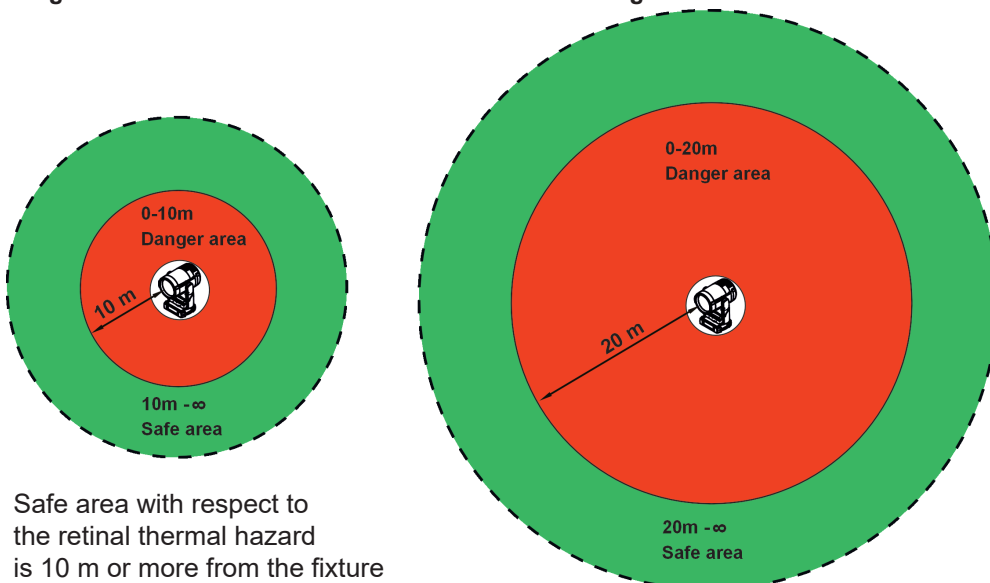

Safe area with respect to the retinal thermal hazard is 10 m or more from the fixture

Safe area with respect to the retinal thermal hazard is 20 m or more from the fixture

The stage mode can be also activated by the display menu (tab "Personality"--> option "Safety control"--> item "Stage Mode"). Safety distance with respect to the retinal thermal hazard in the Stage mode is 40 m unless changed by DMX command on the channel 8.

If the fixture in the Stage mode is switched off and on again, the safety distance of 40 m will stay unless change by DMX command on the channel 8 is made.

The option Default Settings sets the fixture to the Stage mode with safety distance of 40 m unless change by DMX command on the channel 8 is made.

Table of min. distance from illuminated surface for different Stage modes:

| Stage mode safe distance           | Min. distance from illuminated surface |
|------------------------------------|--|
| Stage mode safe distance from 10 m | min. 7 m                               |
| Stage mode safe distance from 20 m | min. 16 m                              |
| Stage mode safe distance from 30 m | min. 22 m                              |
| Stage mode safe distance from 40 m | min. 31 m                              |
| Stage mode safe distance from 50 m | min. 35 m                              |
| Stage mode safe distance from 60 m | min. 38 m                              |
| Stage mode safe distance from 70 m | min. 41 m                              |

**SKY MODE** - the fixture utilize all power of the light source during all procedures of its operation.

**The device operated in the SKY MODE must not be pointed at any time and any circumstances to the spectators or to the spaces where people can appear.**

The light output from the device in the SKY MODE must not aim

- to the area where people or animals can occur
- to the populated area
- to the area where a risk of glare of drivers or pilots can occur
- to the area where optical security systems are installed
- to the area where reflective elements are installed (e.g. mirrors, panels, etc)

**SKY MODE - Retinal thermal hazard distance: min. 80m**

**SKY MODE - Thermal hazard distance from illuminated surfaces: min. 45m**

The Sky mode is signaled by red background of the fixture display - examples of screens.

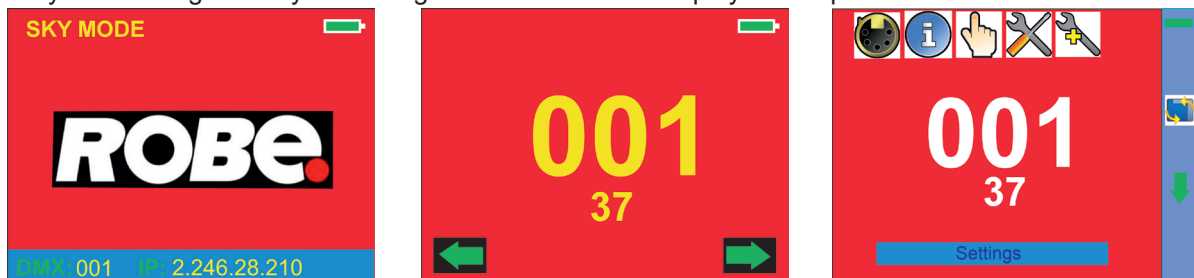

The Sky mode can be activated by DMX command on the channel 8 - Safety control (DMX values 41-42) or by the display menu (tab "Personality"--> option "Safety control"-->item "Sky Mode").

## 4.8 Allowed zoom/focus positions

The iBolt's internal safety system does not allow some combinations of zoom and focus in order to meet standard for Class 1 laser device and risk group 3.

All combination of zoom/focus in the marked red triangular area are prohibited by software and controlled via internal safety system - see the picture below.

E.g., you can set up zoom 0 DMX and focus 255 DMX but internally value of the focus stays at value 226 DMX.. The zoom and focus limitations apply to both modes (Stage and Sky). This restriction does not apply if the prism 1/prism 2 or frost are inserted in the light beam.

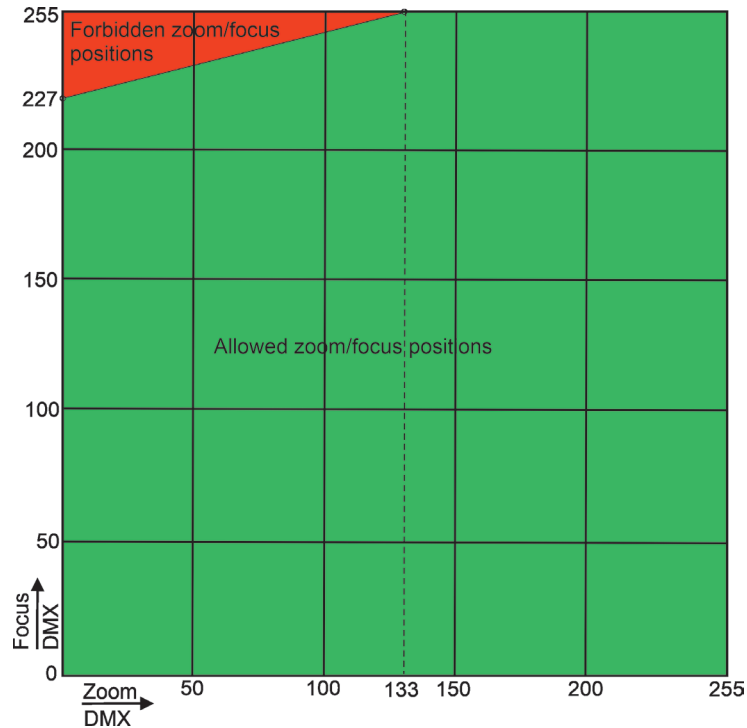

Note: Due to restricted combinations of zoom/focus, the rotating gobo wheel cannot be focused at a distance of 3 metres and less.

## 4.9 Sky mode zone definition

Special functions on the channel Safety control allows you to define zone intended only for the Sky mode operation. The zone is defined by means of setting of the pan/tilt range and pan range of the head movement.

### Tilt zone definition for Sky mode

1. Use the Tilt/Tilt fine channels and move the head to the "**Tilt min.**" position.
2. Channel 8 - go on the command "Tilt min." (59-60 DMX) and stay on it for three seconds.  
Saving of the "Tilt min." value is indicated by flashing of the fixture for three seconds (4 flashes per second for a period of three seconds)
3. Use the Tilt/Tilt fine channels and move the head to the "**Tilt max.**" position.
4. Channel 8 - go on the command "Tilt max." (61-62 DMX) and stay on it for three seconds.  
Saving of the "Tilt max." value is indicated by flashing of the fixture for three seconds (4 flashes per second for a period of three seconds).  
Note:DMX values saved in the items "Tilt min". and "Tilt max". may be interchanged, e.g. behaviour of the fixture with Tilt min.=45/Tilt max.=145 will be the same as behaviour of the fixture with Tilt min.=145/Tilt max.=45.
5. Channel 8 - set behaviour of the fixture outside of the Sky mode zone . You can select from two options:
  - close light output from the fixture - option "**Limited intensity zone Cut-off**".(this option is set as default)
  - select desired Stage mode - option "**Limited intensity zone Stage mode from X m**".
6. In case that activated Lidar is disruptive, switch it off (channel 8, DMX value 0-2).

### **Safety control - channel 8**

| DMX value | Function   |
|-----------|--|
| 59-60     | Tilt min. (full intensity zone definition)       |
| 61-62     | Tilt max. (full intensity zone definition)       |
| 63-64     | Pan min. (full intensity zone definition)        |
| 65-66     | Pan max. (full intensity zone definition)        |
| 67-68     | Limited intensity zone Cut-off (fixture default) |
| 69-70     | Limited intensity zone Stage mode from 10 m      |
| 71-72     | Limited intensity zone Stage mode from 20 m      |
| 73-74     | Limited intensity zone Stage mode from 30 m      |
| 75-76     | Limited intensity zone Stage mode from 40 m      |
| 77-78     | Limited intensity zone Stage mode from 50 m      |
| 79-80     | Limited intensity zone Stage mode from 60 m      |
| 81-82     | Limited intensity zone Stage mode from 70 m      |
| 83-84     | Reset to default (P/T intensity zone)            |

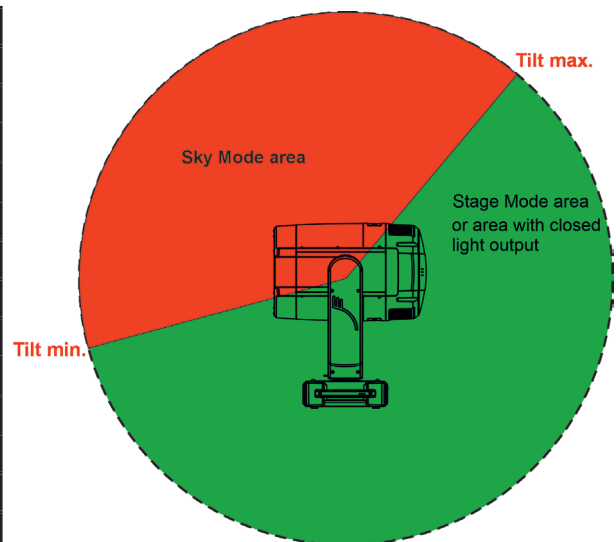

**Important.** If you need to cancel or re-define Tilt zone for Sky mode, you have to reset Sky mode zone (option "**Reset to default (P/T intensity zone)**") and repeat steps 1-5 if you want to define the new Tilt zone for Sky mode. Activation of the item "**Reset to default (P/T intensity zone)**" is indicated by flashing of the fixture for three seconds (4 flashes per second for a period of three seconds).

### Pan zone definition for Sky mode

1. Use the Pan/Pan fine channels and move the head to the "**Pan min.**" position.
2. Channel 8 - go on the command "Tilt min." (59-60 DMX) and stay on it for three seconds.  
Saving of the "Pan min." value is indicated by flashing of the fixture for three seconds (4 flashes per second for a period of three seconds)
3. Use the Pan/Pan fine channels and move the head to the "**Pan max.**" position.
4. Channel 8 - go on the command "Pan max." (61-62 DMX) and stay on it for three seconds.  
Saving of the "Pan max." value is indicated by flashing of the fixture for three seconds (4 flashes per second for a period of three seconds).  
Note:DMX values saved in the items "Pan min". and "Pan max". may be interchanged, e.g. behaviour of the fixture with Pan min.=150/Pan max.=230 will be the same as behaviour of the fixture with Pan min.=230/Pan max.=150.

5. Channel 8 - set behaviour of the fixture outside of the Sky mode zone . You can select from two options:
- close light output from the fixture - option "**Limited intensity zone Cut-off**".(this option is set as default)
  - select desired Stage mode - option "**Limited intensity zone Stage mode from X m**".
6. In case that activated Lidar is disruptive, switch it off (channel 8, DMX value 0-2).

Note. the pan zone limiting for Sky mode defined in steps 1-5 will be also used at the continual rotation of the fixture head in the pan direction.

### Safety control - channel 8

| DMX value | Function  |
|-----------|---|
| 59-60     | Tilt min. (full intensity zone definition)              |
| 61-62     | Tilt max. (full intensity zone definition)              |
| 63-64     | <b>Pan min. (full intensity zone definition)</b>        |
| 65-66     | <b>Pan max. (full intensity zone definition)</b>        |
| 67-68     | <b>Limited intensity zone Cut-off (fixture default)</b> |
| 69-70     | <b>Limited intensity zone Stage mode from 10 m</b>      |
| 71-72     | <b>Limited intensity zone Stage mode from 20 m</b>      |
| 73-74     | <b>Limited intensity zone Stage mode from 30 m</b>      |
| 75-76     | <b>Limited intensity zone Stage mode from 40 m</b>      |
| 77-78     | <b>Limited intensity zone Stage mode from 50 m</b>      |
| 79-80     | <b>Limited intensity zone Stage mode from 60 m</b>      |
| 81-82     | <b>Limited intensity zone Stage mode from 70 m</b>      |
| 83-84     | <b>Reset to default (P/T intensity zone)</b>            |

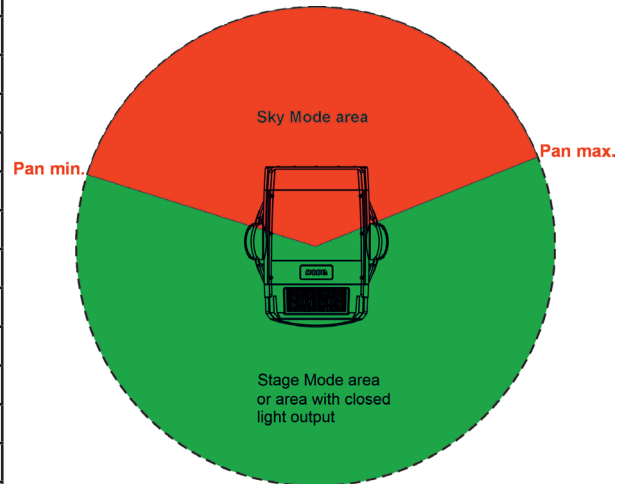

**Important.** If you need to cancel or re-define Pan zone for Sky mode, you have to reset Sky mode zone (option "**Reset to default (P/T intensity zone)**") and repeat steps 1-5 if you want to define the new Pan zone for Sky mode.

Activation of the item "**Reset to default (P/T intensity zone)**" is indicated by flashing of the fixture for three seconds (4 flashes per second for a period of three seconds).

It is possible to set limitation only for pan or only for tilt, there is no requirement that both pan and tilt must be limited for the Sky mode.

Example: Tilt zone for Sky mode is defined, pan is without definition. Sky mode in the tilt movement is limited but in pan movement is without limitation.

The item on the channel 8 "**Reset to default (P/T intensity zone)**" resets both single zone definition (pan or tilt) and compound zone definition (pan and tilt together).

## 4.10 Fixture operation with LIDAR

The fixture is equipped with two LIDAR sensors placed on the front of the head (under glass covers).

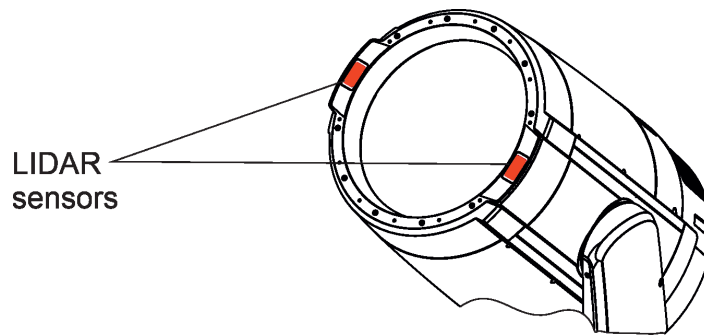

Behaviour of the LIDAR sensors can be set by means of the channel 8 (Safety control). The channel allows you to set a distance to which the light output from the fixture will be automatically closed if some obstacle (person, object) will appear in the light beam. The light output from the fixture is automatically restored after removing the obstacle from the light beam.

Default distance is set at 5 metres (fixture from factory). The LIDAR sensors can be disabled by sending DMX command in range of 0-2 DMX on the channel 8.

A distance from an obstacle to the moving head, which is measured by LIDAR sensors, is displayed in the display menu LIDAR Status (tab Info-->LIDAR Status).

**The LIDAR sensors works only in a clean environment, they do not work in smoky or rainy environment or in environment polluted in another way (confetti, pyrotechnical effects, etc.)!**

Activated LIDAR sensors are intended especially for programming of the show, when technical staff can appear on the stage in a risk distance from the fixture.

**Example:** The channel 8 (Safety control ) is set at 9-10 DMX - LIDAR is active to 15 m.

If some obstacle will appear in a distance range of 0-15 m from the edge of the moving head, the light output will be closed. It does not matter if one or both sensors detect the obstacle.

Some obstacle in distance above 15 m will not influence the light output from the fixture.

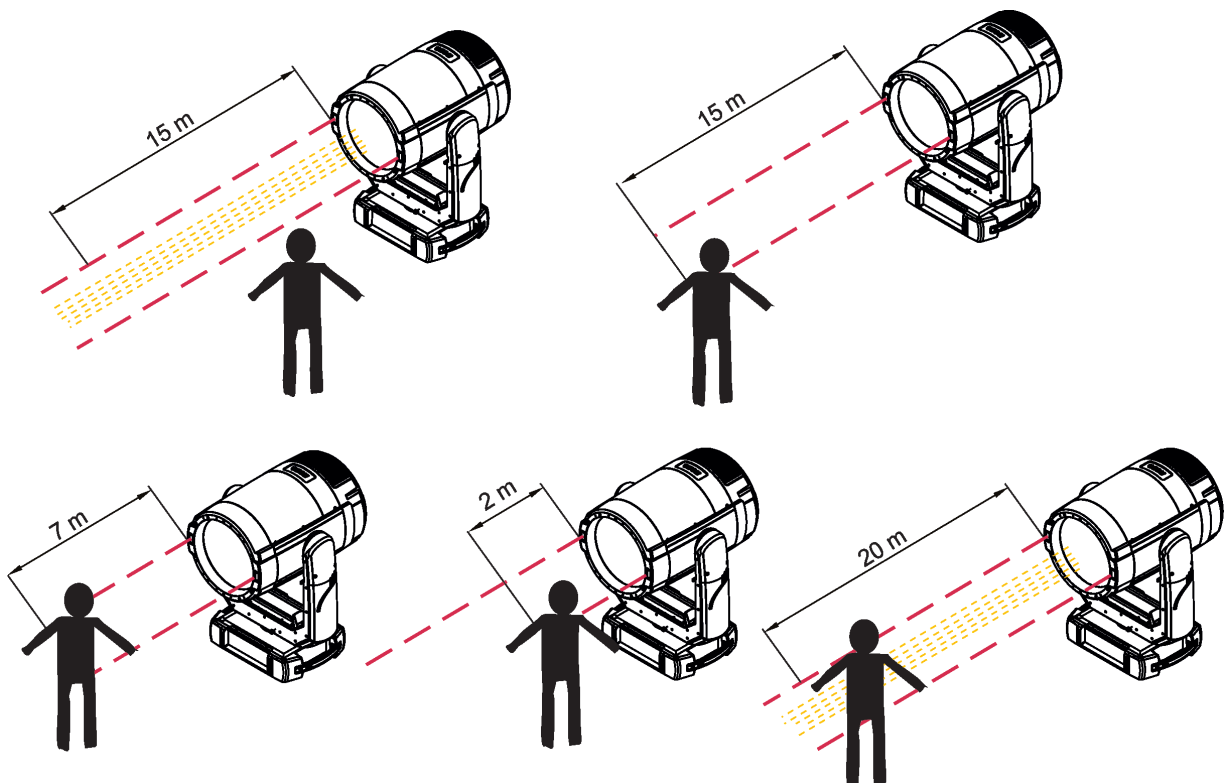

## 5. Checking the IP65 integrity of the fixture.

The Robin iBOLT is IP65 rated lighting fixture which has been designed to be protected against the ingress of dust and pressure water jets from any direction.

**1. Smart pressure test** - for this test serves the function "Pressure Test" in the tab Service. Unique testing procedure allows you easy testing of the IP65 integrity of the fixture. You do not need any external device connected to the fixture for running the test.

The fixture has to be connected to mains (must not be in Standby mode) and a head temperature (at pressure sensor) cannot be higher than 30°C. The pressure test takes about 8 minutes and it should be run immediately after connecting the device to the mains, while it is cold. The pressure test can be repeated at earliest 2 minutes after last pressure test.

The function "Pressure Test" should be run after the following actions:

- **unscrewing/screwing back any watertight cover** (e.g. due to gobos or frosts change)
- **replacing pan or tilt motor**
- **replacing light source**
- **replacing desiccants in the fixture arm (two tubes with silica gel).**

The pressure test can be also run by DMX command (channel Power/Special function) or from web interface REAP (Robe Ethernet Access Portal). During the pressure test fixture does not respond to DMX commands (except DMX values 28-29 on the channel Power/Special functions).

Examples of screens (front panel display) of the smart pressure test:

Fixture waits for 10 minutes period elapsing (inside of the fixture is too hot)

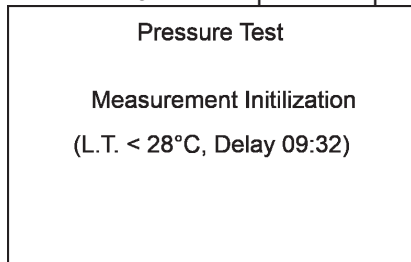

Fixture waits for 2 minutes period elapsing (pressure test was repeated too early)

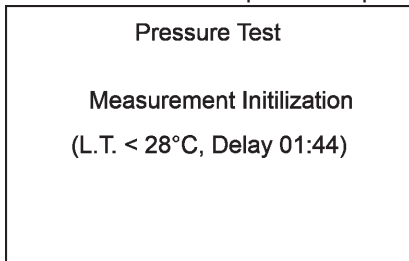

Setting fans

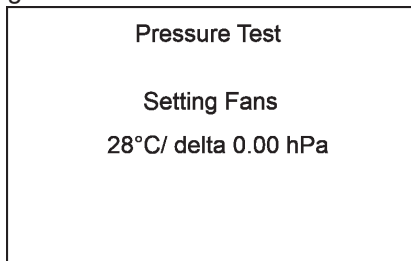

Test in progress

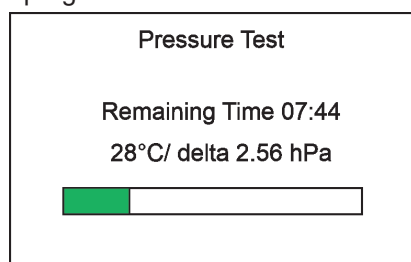

Legend:

07:44 .....Remaining Time (minutes) to finish of pressure test.  
28°C.....Temperature at pressure sensor.  
delta 2.56 hPa...Pressure difference.  
The pressure difference has to be >7 hPa for successful test.

Test passed

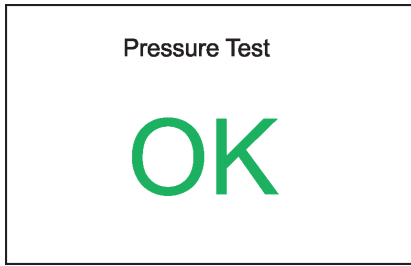

Test failed

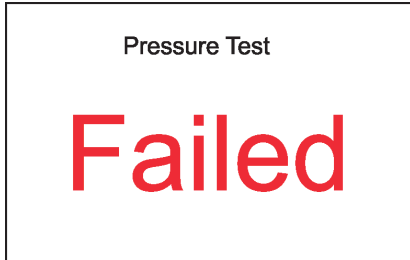

If the first pressure test failed and the second is OK, the fixture complies with IP65 integrity. If the pressure test twice fails despite checking of correct tightening of the cover screws and gaskets under covers, the fixture has to be tested by means of "Enhanced pressure test". For this type of pressure test is needed the Pressure IP Testing Set ROBE (P/N 10980659). Please ask your ROBE distributor for help.

The message "Valve Seal Error" means that valve or coil in the valve is defective or there is a connection problem.

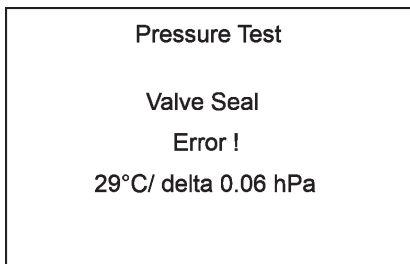

Check the connection between the valve and head, especially cable connector. Other reason can be faulty coil in the valve or faulty valve.



Cable connector  
(arm without tilt lock)

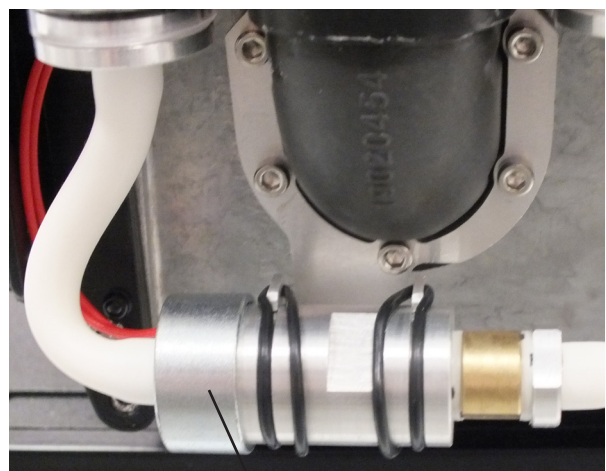

Valve  
(arm without tilt lock)



The message "Not Available At The Moment" means that the fixture is not connected to mains.

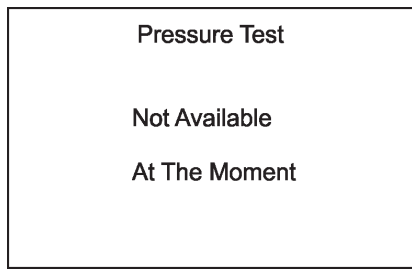

**2. Enhanced pressure test** - a special equipment Pressure IP Testing Set ROBE (P/N 10980659) is intended for this kind of pressure test. Only trained technician should handle the equipment.

Pressure IP Testing Set ROBE  
in case:

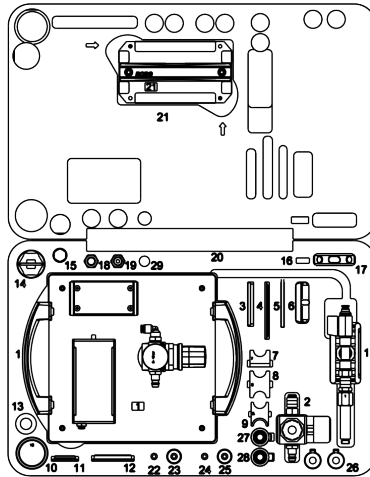

If this equipment is used for pressure test of the fixture, the following values of pressure have to be kept:

Underpressure test.

**300 mbar** for 1 minute, pressure fall can be to **5 mbar** maximally.

Overpressure test

**50 mbar maximally!**

## 6. Operating the fixture at ambient temperatures below 0°C

Design of the Robin iBOLT allows its operation at ambient temperature up to -50°C, but you have to take some specific into account before operating the fixture.

### 1. Fixture is not in Standby mode.

**Robin iBOLT- ambient temperatures from 0°C to -10°C.**

The fixture can be switched off but after powered it on, fixture reset can be delayed in range of 0 - 30 minutes depending on ambient temperature (max. delay is at low ambient temperature). This delay is caused by heating fixture effects on operating temperature. The fixture does not respond to DMX during heating the fixture on operating temperature.

We recommend to switch the fixture on at least 30 minutes before show.

**Robin iBOLT - ambient temperatures from -11°C to -50°C.**

The fixture should be permanently powered on in order to keep operating temperature of fixture's effects. If the fixture is switched off, reset of the fixture will last long time (up to 1 hour depending on ambient temperature) until fixture effects reach their operating temperature.

### 2. Fixture is in Standby mode.

If the fixture is switched to Standby mode (fixture has to be connected to mains), the fixture keeps internal temperature on a level suitable for operation of fixture's effects without delay, heating up of the fixture inside is done automatically.

## 7. Standby mode

The fixture can be switched to Standby mode by means of web interface REAP or DMX command (channel Power/Special functions, DMX values 22-23).

Standby mode can be cancelled by means of web interface REAP, DMX command (channel Power/Special functions, DMX values 24-25) or by switching the fixture off and on.

Standby mode helps conserve power when a fixture is not in use, without fully powering it off. The max. power consumption of the fixture in Standby mode does not exceed 20 W ( if the fixture is heated, power consumption is higher). Standby mode is indicated by a notice on the fixture display.

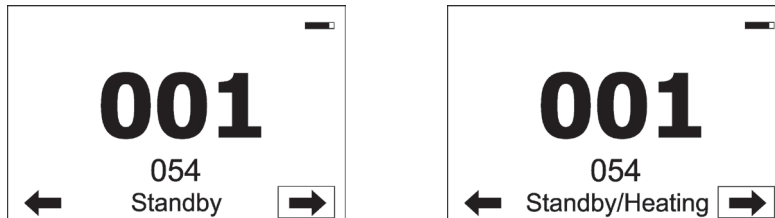

In the Standby mode, the fixture display is functional and can be used for setting of the fixture, but all motors and fans are deactivated, light output is closed.

As the fixture motors are deactivated, the fixture does not respond to DMX values controlling effects but the channel Power /Special functions can be used for fixture settings.

The fixture in Standby mode provides information for RDM and REAP and also can be set its behaviour by means of the RDM and REAP.

Main benefits of Standby mode:

- there is not time delay of fixture reset at ambient temperatures below 0°C.
- By means of REAP user has current information about fixture (settings, temperatures, state of desiccants in the fixture arm).

## 8. Remotely controllable functions

### Colour wheel

This wheel contains 13 dichroic filters + open. The colour wheel can be positioned between two adjacent colours in any position. It is also possible to rotate the colour wheel continuously at different speeds ("Rainbow effect" in both directions).

### CMY+CTO colour mixing system

The CMY color mixing system is based on graduated cyan, magenta, and yellow colour filters. A continuous range of colors may be achieved by varying the amount of each filter from 0 to 100%.

### Static gobo wheel

The static gobo wheel includes 10 metal gobos and 4 beam reducers. Gobo positioning and continual gobo positioning is available as well as a gobo-shake function.

### Rotating gobo wheel

The rotating gobo wheel includes 9 replaceable "SLOT&LOCK" glass gobos rotating in both directions, indexable, + open position. Gobo positioning and gobo selection speed is available as well as a gobo-shake function.

### Prism wheels

Two prism wheels offer 2 x 6-facet linear prism, 2 x 8-facet circular prism, 1 x 32-facet circular prism and 1 x 6-facet linear multicoloured prism. All prisms can be rotated in both directions at different speeds. The 6-facet linear multicoloured prism is used in the paradigm-shifting effects engine - SpektraBeam.

### Zoom

Motorized zoom unit enables zoom between 0.4° - 8°.

### Focus

Motorized focus allows to focus beam from approx. 3 meters to infinity.

## Pan/Tilt

Fast pan/tilt movement due to built-in electronic motion stabilizer (EMS). The electronic motion stabilizer ensures precise position of the fixture's head during its movement and reduces its swinging when the truss shakes. Motionless absolute positioning system for Pan and Tilt (MAPS)  
 Pan /Tilt movement range: 0-540°/0-265°.

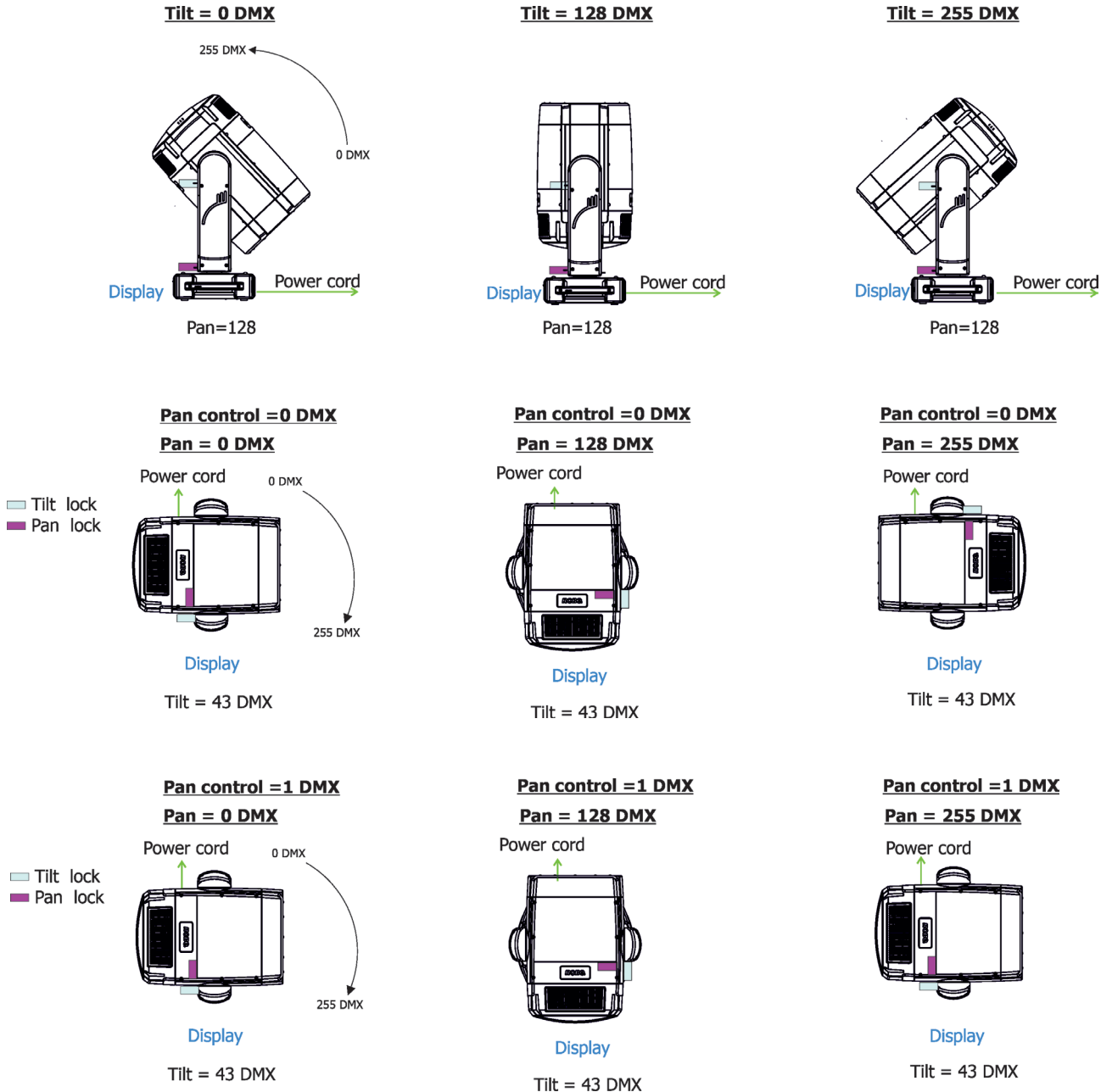

Continual pan rotation.

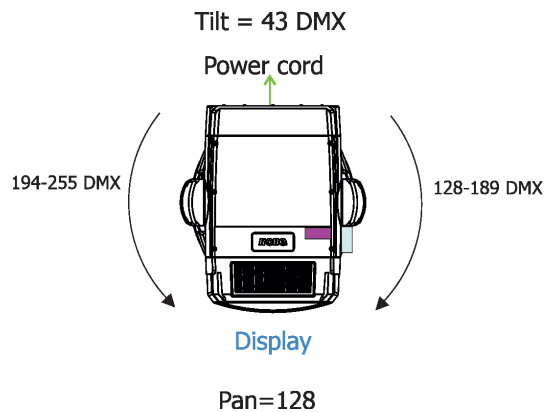

**Pan control channel - shortcut on/off**

Pan control channel = 0 DMX (default value). Pan range = 540°, shortcut Off

If the pan receives a value 255 DMX from a DMX controller and next received DMX value for the pan will be 0 DMX, the pan will move to the point 0 DMX around entire track 255-0 DMX.

**Example 1:** DMX controller sends DMX values in the order: 0 (point A)-->10 (point B)-->128 (point C)--> 213 (point D)-->255(point E)-->10(point F)-->100(point G).

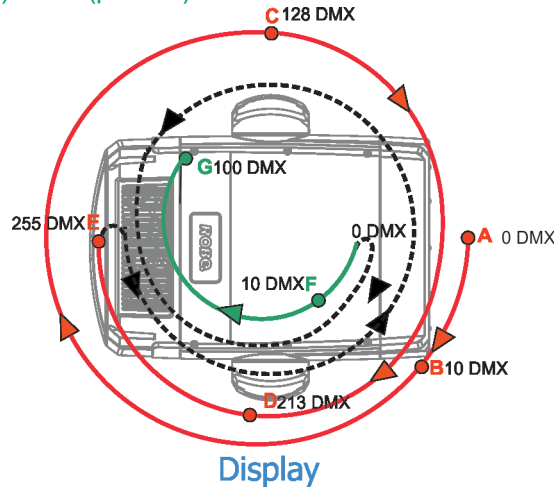

Picture for illustration only

Pan control channel = 1 DMX. Pan range= 360°, shortcut On

If the pan receives a value 255 DMX from a DMX controller and next received DMX value for the pan will be 0 DMX, the pan will move to the point 0 DMX directly without changing its direction of movement.

**Example 2:** DMX controller sends DMX values in the order: 0 (point A)-->10 (point B)-->128 (point C)--> 213 (point D)-->255(point E)-->10(point F)-->100(point G).

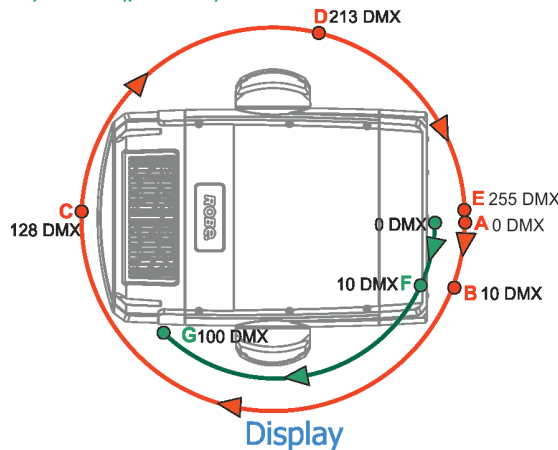

Picture for illustration only

**Example 3:** you need to rotate head continually in pan and close light output in two pan positions.

1. Set Pan control channel at 1.
2. Create four cues, pan DMX values are changing in the cues as follows:
  - Cue 1: 40, 41...94,95.
  - Cue 2: 95, 97....164,165.
  - Cue 3: 165,167....214,215.
  - Cue 4: 215,217....38,40
3. Set blackout at cue 1 and cue 3.
4. Run cues 1-4 continually (1-->2-->3-->4-->1-->2-->3-->4....)

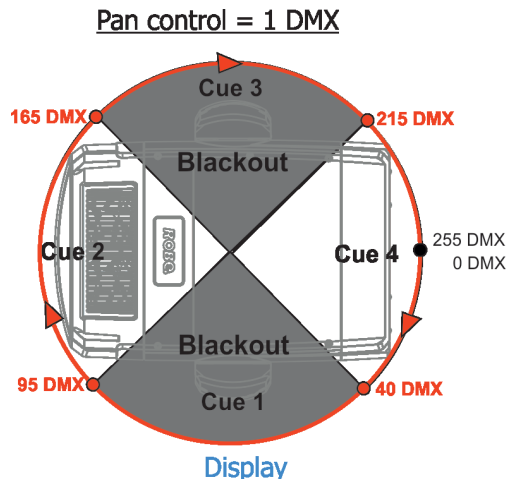



Picture for illustration only

## 9. Control menu map

Default settings=**Bold print**

| Tab   | Level 1              | Level 2                 | Level 3            | Level 4     | Level 5 | Level 6 |
|---|----------------------|-------------------------|--------------------|-------------|---------|---------|
| Addressing  | DMX Address          | 001-512                 |                    |             |         |         |
|    | DMX Preset Channels  | Pan                     |                    |             |         |         |
|   |                      | :                       |                    |             |         |         |
|   |                      | Dimmer F.               |                    |             |         |         |
|   | Ethernet Settings    | Ethernet Mode           | Disable            |             |         |         |
|   |                      |                         | ArtNet             |             |         |         |
|   |                      |                         | gMAI               |             |         |         |
|   |                      |                         | gMA2               |             |         |         |
|   |                      |                         | sACN               |             |         |         |
|   |                      |                         |                    |             |         |         |
|   |                      | Ethernet To DMX         | <b>Off</b> , On    |             |         |         |
|   |                      | IP Address/Net Mask     | Default IP Address |             |         |         |
|   |                      |                         | Custom IP Address  |             |         |         |
|   |                      |                         | Net Mask           |             |         |         |
|   |                      | ArtNet Universe         | 0-255              |             |         |         |
|   |                      | MANet settings          | MANet/II Universe  | 01-256      |         |         |
|   |                      |                         | MANet Session ID   | 01-32       |         |         |
|   |                      | sACN Settings           | sACN Universe      | 00001-32000 |         |         |
|   |                      |                         |                    |             |         |         |
| Information   | Fixture Times        | Power On Time           | Total Hours        |             |         |         |
|  |                      |                         | Resetable Hours    |             |         |         |
|   |                      | LEDs On Time            | Total Hours        |             |         |         |
|   |                      |                         | Resetable Hours    |             |         |         |
|   | Fixture Temperatures | Laser LEDs Temp.        | Current            |             |         |         |
|   |                      |                         | Maximum NonRes..   |             |         |         |
|   |                      |                         | Maximum Res..      |             |         |         |
|   |                      | Laser Temp.             | Current            |             |         |         |
|   |                      |                         | Maximum NonRes..   |             |         |         |
|   |                      |                         | Maximum Res..      |             |         |         |
|   |                      | Driver Temp..           | Current            |             |         |         |
|   |                      |                         | Maximum NonRes..   |             |         |         |
|   |                      |                         | Maximum Res..      |             |         |         |
|   |                      | Base Temp..             | Current            |             |         |         |
|   |                      |                         | Maximum NonRes.    |             |         |         |
|   |                      |                         | Maximum Res.       |             |         |         |
|   |                      | LIDAR Status            |                    |             |         |         |
|   |                      | RAINS Status            |                    |             |         |         |
|   | Sensors Info         |                         |                    |             |         |         |
|   | DMX Values           | Pan                     |                    |             |         |         |
|   |                      | :                       |                    |             |         |         |
|   |                      | Dimmer Fine             |                    |             |         |         |
|   | Wireless State       | Signal Quality          |                    |             |         |         |
|   |                      | Unlink Wireless Adapter |                    |             |         |         |
|   | Power Channel state  |                         |                    |             |         |         |
|   | Software Versions    | Display System          |                    |             |         |         |
|   |                      | M                       |                    |             |         |         |
|   |                      | L                       |                    |             |         |         |
|   |                      | C                       |                    |             |         |         |
|   |                      | G                       |                    |             |         |         |
|   |                      | MB                      |                    |             |         |         |
|   |                      | H                       |                    |             |         |         |
|   |                      | O                       |                    |             |         |         |

| Tab   | Level 1             | Level 2              | Level 3              | Level 4        | Level 5 | Level 6 |
|---|---------------------|----------------------|----------------------|----------------|---------|---------|
|   |                     | P                    |                      |                |         |         |
|   |                     | DL                   |                      |                |         |         |
|   |                     | GR                   |                      |                |         |         |
|   |                     | FAN                  |                      |                |         |         |
|   |                     | T                    |                      |                |         |         |
|   | SW HW Versions      | M                    |                      |                |         |         |
|   |                     | O                    |                      |                |         |         |
|   |                     | L                    |                      |                |         |         |
|   |                     | P                    |                      |                |         |         |
|   |                     | C                    |                      |                |         |         |
|   |                     | DL                   |                      |                |         |         |
|   |                     | G                    |                      |                |         |         |
|   |                     | GR                   |                      |                |         |         |
|   |                     | MB                   |                      |                |         |         |
|   |                     | FAN                  |                      |                |         |         |
|   |                     | H                    |                      |                |         |         |
|   |                     | T                    |                      |                |         |         |
|   | Product IDs         | Mac Address          |                      |                |         |         |
|   |                     | RDM UID              |                      |                |         |         |
|   |                     | RDM Label            |                      |                |         |         |
|   | View Logs           | Fixture Errors       |                      |                |         |         |
|   |                     | Fixture States       | Power On             |                |         |         |
|   |                     |                      | Power Off            |                |         |         |
|   |                     | Fixture Position     |                      |                |         |         |
|   |                     | Fixture Temperatures | LEDs B.1 Temperature |                |         |         |
|   |                     |                      | LEDs B.2 Temperature |                |         |         |
|   |                     |                      | Base Temperature     |                |         |         |
|   |                     | Sensors Logs         |                      |                |         |         |
|   |                     | Pressure Tests Logs  |                      |                |         |         |
|   |                     |                      |                      |                |         |         |
| Personality   | DMX Preset Channels | Pan                  |                      |                |         |         |
|  |                     | :                    |                      |                |         |         |
|   |                     | Dimmer F.            |                      |                |         |         |
|   | DMX Input           | <b>Wired</b>         |                      |                |         |         |
|   |                     | Wireless             |                      |                |         |         |
|   |                     | Wireless In/XLR Out  |                      |                |         |         |
|   | Safety control      | <b>Stage Mode</b>    |                      |                |         |         |
|   |                     | Sky Mode             |                      |                |         |         |
|   | SD card             | Disconnect SD card   |                      |                |         |         |
|   |                     | Format SD card       |                      |                |         |         |
|   | Pan/Tilt Settings   | Pan Reverse          | <b>Off, On</b>       |                |         |         |
|   |                     | Tilt Reverse         | <b>Off, On</b>       |                |         |         |
|   |                     | Pan/Tilt Feedback    | <b>Off, On</b>       |                |         |         |
|   |                     | Pan/Tilt mode        | Time                 |                |         |         |
|   |                     |                      | <b>Speed</b>         |                |         |         |
|   | Pan/Tilt EMS        | <b>Off, On</b>       |                      |                |         |         |
|   | Follow Spot Mode    | <b>Off</b>           |                      |                |         |         |
|   |                     | Soft                 |                      |                |         |         |
|   |                     | Medium               |                      |                |         |         |
|   |                     | Hard                 |                      |                |         |         |
|   | Blackout Settings   | Blackout During M.C. | <b>Off, On</b>       |                |         |         |
|   |                     | Blackout while:      | Pan/Tilt moving      | <b>Off, On</b> |         |         |
|   |                     |                      | Gobo Wheel Moving    | <b>Off, On</b> |         |         |
|   | Frequency Setup     | 300 Hz               |                      |                |         |         |
|   |                     | <b>600Hz</b>         |                      |                |         |         |

| Tab   | Level 1                | Level 2                          | Level 3            | Level 4 | Level 5 | Level 6 |
|---|------------------------|----------------------------------|--------------------|---------|---------|---------|
|   |                        | 1200Hz                           |                    |         |         |         |
|   |                        | 2400Hz                           |                    |         |         |         |
|   |                        | Frequency Adjust                 |                    |         |         |         |
|   | AutoParking Pos.       | <b>Off</b>                       |                    |         |         |         |
|   |                        | On                               |                    |         |         |         |
|   | Init Effect Positions  | Pan                              | 0-255              |         |         |         |
|   |                        | :                                |                    |         |         |         |
|   |                        | Dimmer Fine                      | 0-255              |         |         |         |
|   | Reset Init Effect Pos. |                                  |                    |         |         |         |
|   | Screen Settings        | Display Intensity                | 1-10               |         |         |         |
|   |                        | Screen Saver Delay               | <b>Off</b> -10min. |         |         |         |
|   |                        | Touchscreen Lock                 | <b>Off</b> -10min. |         |         |         |
|   |                        | Recalibrate Touchscreen          |                    |         |         |         |
|   |                        | Display Orientation              | Normal             |         |         |         |
|   |                        |                                  | Inverted           |         |         |         |
|   |                        |                                  | <b>Auto</b>        |         |         |         |
|   | Temperature Unit       | °C, °F                           |                    |         |         |         |
|   | Fan Settings           | Fan mode                         | <b>Auto</b>        |         |         |         |
|   |                        |                                  | High               |         |         |         |
|   |                        |                                  | Quiet              |         |         |         |
|   | Dimmer Curve           | Linear                           |                    |         |         |         |
|   |                        | <b>Square Law</b>                |                    |         |         |         |
|   | Gobo Indexing          | <b>Max. Speed &amp; ShortCut</b> |                    |         |         |         |
|   |                        | Follow Speed & Direction         |                    |         |         |         |
|   |                        | Max. Speed & ShortCut            |                    |         |         |         |
|   | Date & Time Settings   |                                  |                    |         |         |         |
|   | Focus Tracking         | <b>Off, On</b>                   |                    |         |         |         |
|   | Default Settings       |                                  |                    |         |         |         |
|   | Memory Tools           | SD card                          | SD State           |         |         |         |
|   |                        |                                  | Mount SD           |         |         |         |
|   |                        |                                  | Unmount SD         |         |         |         |
|   |                        |                                  | Format SD          |         |         |         |
|   | Password Protection    | <b>Off, On</b>                   |                    |         |         |         |
|   | Reset Web Password     |                                  |                    |         |         |         |
|   |                        |                                  |                    |         |         |         |
| Manual Control  | Reset Functions        | Total Fixture Reset              |                    |         |         |         |
|  |                        | Pan/Tilt reset                   |                    |         |         |         |
|   |                        | Color Reset                      |                    |         |         |         |
|   |                        | Gobo Reset                       |                    |         |         |         |
|   |                        | Pan Reset                        |                    |         |         |         |
|   |                        | Tilt Reset                       |                    |         |         |         |
|   |                        | Zoom/Foc/Pri/Fro. Reset          |                    |         |         |         |
|   |                        | Total System Reset               |                    |         |         |         |
|   | Manual Effect Control  | Pan                              | 0-255              |         |         |         |
|   |                        | :                                |                    |         |         |         |
|   |                        | Dimmer Fine                      | 0-255              |         |         |         |
|   |                        |                                  |                    |         |         |         |
| Stand -Alone  | Test Sequences         | Dynamic Mode                     |                    |         |         |         |
|  |                        | Static Mode                      | Pan                | 0-255   |         |         |
|   |                        |                                  | Tilt               | 0-255   |         |         |
|   |                        |                                  | Zoom               | 0-255   |         |         |
|   |                        |                                  | Focus              | 0-255   |         |         |
|   |                        |                                  |                    |         |         |         |



| Tab   | Level 1               | Level 2                   | Level 3           | Level 4 | Level 5 | Level 6 |
|---|-----------------------|---------------------------|-------------------|---------|---------|---------|
| Service   | Pressure Test         |                           |                   |         |         |         |
|  | Adjust DMX Values     | Pan                       | 0-255             |         |         |         |
|   |                       | :                         |                   |         |         |         |
|   |                       | Dimmer Fine               | 0-255             |         |         |         |
|   | Calibrations          | Calibrate Effects         | Pan               | 0-255   |         |         |
|   |                       |                           | Tilt              | 0-255   |         |         |
|   |                       |                           | Static Gobo       |         |         |         |
|   |                       |                           | Rot. Gobo Wheel 1 | 0-255   |         |         |
|   |                       |                           | R. Gobo Index 1/1 | 0-255   |         |         |
|   |                       |                           | :                 | :       |         |         |
|   |                       |                           | R. Gobo Index 1/9 | 0-255   |         |         |
|   |                       |                           | Prism 1           | 0-255   |         |         |
|   |                       |                           | Prism 1 Rot.1     | 0-255   |         |         |
|   |                       |                           | Prism 1 Rot.2     | 0-255   |         |         |
|   |                       |                           | Prism 1 Rot.3     | 0-255   |         |         |
|   |                       |                           | Prism 2           | 0-255   |         |         |
|   |                       |                           | Prism 2 Rot.1     | 0-255   |         |         |
|   |                       |                           | Prism 2 Rot.2     | 0-255   |         |         |
|   |                       |                           | Prism 2 Rot.3     | 0-255   |         |         |
|   |                       |                           | Zoom              | 0-255   |         |         |
|   |                       |                           | Focus             | 0-255   |         |         |
|   |                       |                           | Frost             | 0-255   |         |         |
|   |                       |                           | Colour Wheel      | 0-255   |         |         |
|   |                       |                           | Color Cyan        | 0-255   |         |         |
|   |                       |                           | Color Magenta     | 0-255   |         |         |
|   |                       |                           | Color Yellow      | 0-255   |         |         |
|   |                       | Calibrate Pan/Tilt EMS    |                   |         |         |         |
|   |                       | Calibrate Pan/Tilt Reset  |                   |         |         |         |
|   |                       | Load Default Calibrations |                   |         |         |         |
|   | Rotating Gobos Change | Gobo Carousel 1           | G1-Mg, G2...G9    |         |         |         |
|   |                       |                           | Gobo Offset       |         |         |         |
|   | Update Software       |                           |                   |         |         |         |



## 10. Control menu

The fixture is equipped with the QVGA screen with battery backup and four control buttons which allow you to set the fixture's behaviour according to your needs, obtain information on its operation, test its various parts and program it, if it has to be used in a stand-alone mode. The fixture supports NFC (Near-Field Communication).

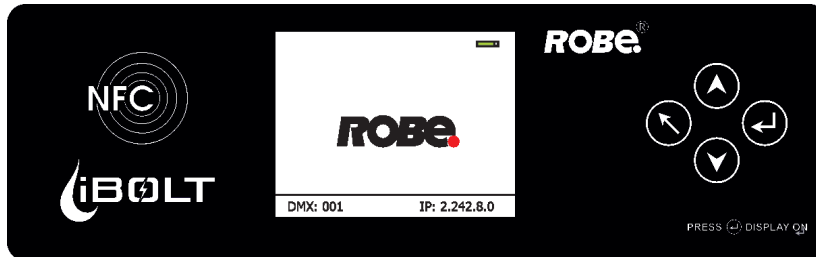









### NFC interface and control buttons on the front panel



### Control buttons on the front panel

-  - [ESCAPE] button used to leave the menu without saving changes.
-  - [NEXT] , [PREV] buttons for moving between menu items and symbols, adjusting values.
-  - [ENTER/Display On] button used to enter the selected menu item and to confirm adjusted value. If the fixture is disconnected from mains, the button switches the screen on (for a while).

### Icons used in the screen menu:

-  - [back arrow] used to move back to the previous screen (menu).
-  - [up arrow] used to move up on the previous page.
-  - [down arrow] used to move down on the next page.
-  - [confirm] used to save adjusted values, to leave menu or to perform desired action.
-  - [cancel] used to leave menu item without saving changes.
-  - [confirm+copy] used to save adjusted values and copy them to the next prog. step.
-  - [warning icon] used to indicate some error which has occurred in the fixture.
-  - [Ethernet] used to indicate Ethernet connected.
-  - [menu rotation] used to rotate menu 180 degrees from current orientation.
-  - [slider control] used to recall slider system for setting desired value.
-  - [keyboard control] used to recall keyboard system for setting desired value.

After switching the fixture on, the screen shows the screen with the ROBE logo.



The green icon at the top right corner of the screen indicates the level of the display battery charging. If the whole icon is green, the battery is fully charged while the red icon indicates exhausted battery. The battery charges during fixture operation, its charging lasts cca 6 hours.

We recommend that the fixture should be in operation at least 7 hours per week to keep the battery fully charged. If you switch the fixture on and this screen will not appear till 1 minute, switch the fixture off and on again. If the screen lights, the battery is exhausted. In case the screen still does not light, the battery is faulty.

This is also indicated by an error message "Faulty battery" and if such an error message appears the battery should be replaced immediately. The lifetime of the battery is highly dependent on ambient temperature (and consequently on base temperature). If the maximum ambient temperatures (as recorded and displayed in menu: Information -> Fixture Temperatures -> Ambient Temperature -> Maximum NonRes.) are kept within the specified limits, the battery should last for at least two years. Should the ambient temperatures exceed the specified maximum temperature, the lifetime of the batteries could be considerably shortened even up to just one year or less and also result in physical damage (battery leakage) or unreliable fixture functions.

Damage caused by batteries failed due to exceeded maximum ambient temperature cannot be claimed under warranty terms.

Press the [ENTER/Display On] button to display the initial screen with current DMX address:

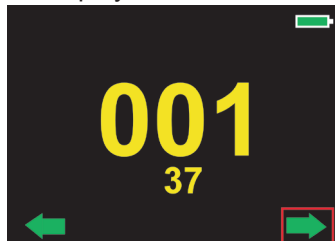

Press the [ENTER/Display On] button to enter the "Address" menu.

An item may be selected from a screen by pressing the [NEXT] or [PREV] buttons to scroll through list items.

Press [ENTER] to select the highlighted item.

**Before first fixture operation, set current date and time in the menu "Date & Time Settings" (menu path: Personality--> Date & Time Settings).**

As the fixture can be operated at wide range of ambient temperatures, suitable environment has to be maintained inside of the fixture. The following messages under DMX address inform you about fixture status.

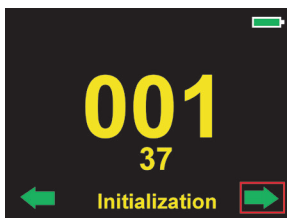

The fixture is waiting for finishing all reset procedures.  
Fixture does not respond to DMX.

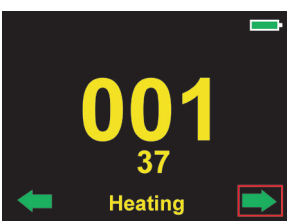

The fixture is waiting for reaching operating temperature of the fixture inside (inside temperature is below 0°C).  
Fixture does not respond to DMX.

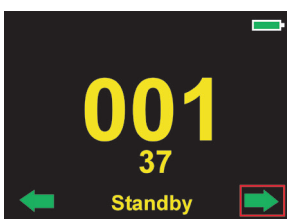

The fixture is in standby mode.  
Fixture effects does not respond to DMX, but display is active. Fixture sends its statuses and recorded physical values ( temperature, humidity, pressure) to the REAP.

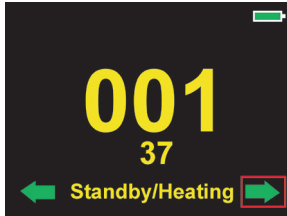

The fixture is in standby mode and inside of the fixture is heated (ambient temperature is below 0°C).  
 Fixture does not respond to DMX, but display is active. Fixture sends its statuses and recorded physical values ( temperature, humidity, pressure) to the REAP.

### Locking/unlocking the screen.

To lock the screen, display the screen with ROBE logo, touch the [ESCAPE] button and slide your finger clockwise in a circular track of 360° across buttons [ESCAPE] --> [NEXT] --> [ENTER/Display On] --> [PREV]--> [ESCAPE]. The sign "Buttons are locked" will appear on the screen. If this sign will not appear, repeat finger sliding again with a different speed.



To unlock the screen, touch the [ESCAPE] button and slide your finger clockwise in a circular track of 360° across buttons [ESCAPE] --> [NEXT] --> [ENTER/Display On] --> [PREV]--> [ESCAPE]. The sign "Buttons are locked" will disappear from the screen. If this sign still remains on the screen, repeat finger sliding again with a different speed.



## 10.1 Tab " Address"



**DMX Address** - Select the menu to set the DMX start address.

Blinking DMX address means that the fixture is either not receiving DMX data or that the set DMX address is higher than allowed, exceeding the DMX footprint of the set DMX mode.

**DMX Preset Channels** - The menu item offers you overview of DMX channels used in the fixture.

**Ethernet Settings** - The menu allows all needed settings for the Ethernet operation

### **Ethernet Mode**

**Disable** - The option disables Ethernet operation.

**Artnet** - Fixture receives Artnet protocol

**gMA1** - Fixture receives MANet 1 protocol

**gMA2** - Fixture receives MANet 2 protocol

**sACN** - Fixture receives sACN protocol

**Ethernet To DMX** - Fixture receives protocol from the Ethernet input and sends DMX data to its DMX output (fixture works as an "Ethernet/DMX converter", next fixture can be connected to its DMX output and you can build a standard DMX chain by connecting another fixtures. Only one fixture has to be connected to the Ethernet.

**IP Address/Net Mask** - Select this menu to set IP address. IP address is the Internet protocol address. The IP uniquely identifies any node (fixture) on a network.

There cannot be 2 fixtures with the same IP address on the network!

**Default IP Address** -Preset IP address, you can set up only first byte of IP address (2 or 10) e.g. **002.019.052.086**.

**Custom IP Address** - The option enables to set up all bytes of IP address.

**Net Mask** - The option enables to set up all bytes of Net Mask.

**ArtNet Universe** - Use this item to set a Universe (0-255). The Universe is a single DMX 512 frame of 512 channels.

**MANet Settings** - Use this menu to set parameters for MANet operation.

**MANet Universe I/II** - The value of this item can be set in range 1-256.

**MANet Session ID** - The value of this item can be set in range 1-32.

**sACN Settings** - Use this menu to set parameters for sACN operation.

**sACN Universe** - The value of this item can be set in range 1-32000.

## 10.2 Tab "Information"



**Fixture Times** - The menu provides readouts of fixture and LED module operation hours.

**Power On Time** - Select this menu to read the number of fixture operation hours.

**Total Hours** - The item shows the total number of the operation hours since the Robin iBOLT has been fabricated.

**Resettable Hours** - The item shows the number of the operation hours that the Robin iBOLT has been powered on since the counter was last reset.

In order to reset this counter to 0, touch the text box next to the item "Resettable Hours:"

**Fixture Temperatures** - The menu is used to view temperatures of the fixture's inside.

**Phosphor Wheel Temp.** - The menu shows temperatures on the laser phosphor wheel.

**Current** - A current temperature on the laser phosphor wheel.

**Maximum NonRes.** - A maximum temperature on the laser phosphor wheel since the fixture has been fabricated.

**Maximum Res.** - A maximum temperature on the laser phosphor wheel since the counter was last reset.

In order to reset counter to 0, touch desired text box under item "Max.Res."

**Laser Diode Temp.** - The menu shows temperatures on the heatsink of the laser light source.

**Current** - A current temperature on the heatsink of the laser light source.

**Maximum NonRes.** - A maximum temperature on the heatsink of the laser light source since the fixture has been fabricated.

**Maximum Res.** - A maximum temperature on the heatsink of the laser light source since the counter was last reset.

In order to reset counter to 0, touch desired text box under item "Max.Res."

**Driver Temp.** - The menu shows temperature on the laser unit control PCB in the fixture head.

**Current** - A current temperature on the laser unit control PCB.

**Maximum NonRes.** - A maximum temperature on the laser unit control PCB since the fixture has been fabricated.

**Maximum Res.** - A maximum temperature on the laser unit control PCB since the counter was last reset.

In order to reset this counter to 0, touch the text box next to the item "Maximum Res."

**PSU Temp.** - The menu shows temperature of power supply unit in the fixture base.

**Current** - A current temperature of power supply unit.

**Maximum NonRes.** - A maximum temperature of power supply unit since the fixture has been fabricated.

**Maximum Res.** - A maximum temperature of power supply unit since the counter was last reset.

In order to reset this counter to 0, touch the text box next to the item "Maximum Res."

**Base Temp.** - The menu shows temperature on the display PCB in the fixture base.

**Current** - A current temperature on the display PCB.

**Maximum NonRes.** - A maximum temperature on the display PCB since the fixture has been fabricated.

**Maximum Res.** - A maximum temperature on the display PCB since the counter was last reset.

In order to reset this counter to 0, touch the text box next to the item "Maximum Res."

**LIDAR Status** - After entering the menu, a distance from the fixture to the illuminated surface is displayed. As the fixture is equipped with two LIDARs on the head, two distance values are displayed.

**RAINS Status** - The menu item gives you information about environment in the fixture.

RAINS (Robe Automatic Ingress Neutralization System) manages humidity, temperature and pressure control using an active monitoring system to automatically remove any moisture detected within the fixture and provides permanent monitoring to ensure peak performance of the fixture.

Silica gel desiccants in the fixture arm

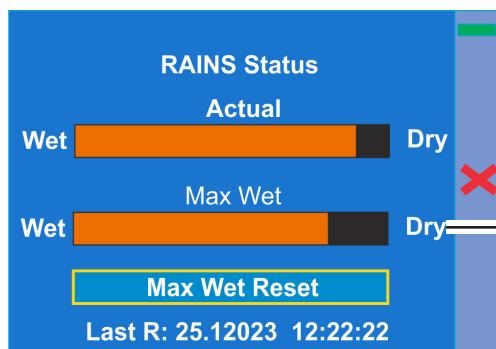

The bar chart **Actual** informs you about current humidity in the fixture. The bar chart changes depending on humidity, temperature and pressure in the fixture. The bar chart depends on current conditions in the fixture and can be different at start of fixture operation, after 10 minutes of its operating, after closing fixture dimmer etc.

The bar chart **MAX WET** informs you about maximum humidity achieved in the fixture since the chart was last reset. The bar chart also informs you about saturation of silica gel desiccants in the fixture arm with water and is deciding indicator for their checking and replacement.

The option **MAX WET reset** resets the bar chart MAX WET. Date and time of last reset is displayed below the option.

Examples of RAINS statuses:

**Dry desiccants in the fixture arm**

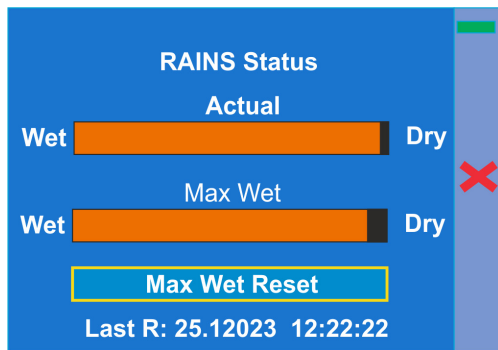

**Desiccants in the fixture arm partially saturated with water**

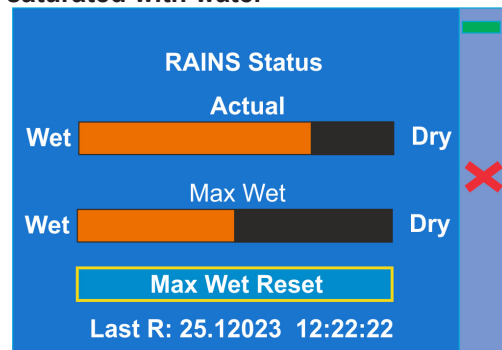

**Desiccants in the fixture arm fully saturated with water**

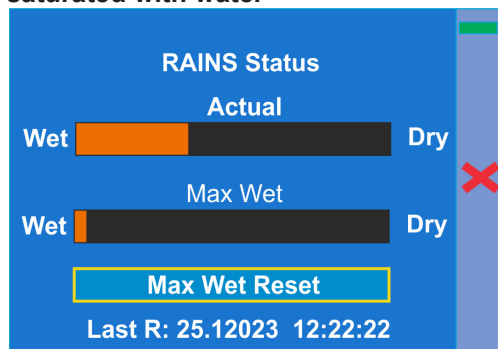

Silica gel desiccants in the fixture arm are saturated with water and should be replaced.

**After replacing them, reset the item MAX WET.**

It is not necessary to replace silica gels desiccants in plastic boxes in the fixture head and base. These desiccants should be checked (and replaced if it is needed) at removing head or base covers, e.g. at gobo replacement or some service intervention.

**Sensors Info** - The menu items shows you current conditions in the fixture head (at pressure sensor): temperature, relative humidity and pressure.

**DMX Values** - The menu items allows you to read DMX values of each channel received by the fixture.

**Wireless State** - The menu serves for reading of the wireless operation status.

**Unlink Wireless Adaptor** - The item serves for unlinking the fixture from a DMX transmitter.

If the wireless module is not installed in the fixture, message "Wireless Module Not Installed" will appear.

**Power Channel State** - Select this item to see current setting of the functions, which can be set by menu items in "Personality" as well as by DMX command at channel "Power/Special functions".

**Colour Functions State** - Select this item to see current setting of the colour functions, which can be set by menu items in "Personality" as well as by DMX command at channel "Colour functions".

**Software Version** - Select this item to read software versions of fixture processors for internal communication.

**Display System** - A display processor on the display board in the fixture base

**Module M** - a Pan/Tilt processor

**Module L** - a Laser source control processor

**Module C** - a Colour wheels control processor

**Module G** - a Gobo wheels control processor

**Module MB** - a Memory control processor

**Module H** - a Laser control processor (backup)

- Module O** - a Focus/Zoom control processor
- Module P** - a Prisms/frost control processor
- Module DL**- a Data Logger control module
- Module GR**- a Gyroscope control module
- Module FAN**- a Fans control module
- Module T** - a Focus/Zoom control processor (backup)
- Module T2** - a Prism/Frost control processor (backup )

**SW HW Version** - Select this item to read hardware versions of PCBs and their software versions.

**Display System** - A display processor on the display board in the fixture base

**Module M** - a Pan/Tilt processor

**Module L** - a Laser source control processor

**Module C** - a Colour wheels control processor

**Module G** - a Gobo wheels control processor

**Module MB** - a Memory control processor

**Module H** - a Laser control processor (backup)

**Module O** - a Focus/Zoom control processor

**Module P** - a Prisms/frost control processor

**Module DL**- a Data Logger control module

**Module GR**- a Gyroscope control module

**Module FAN**- a Fans control module

**Module T** - a Focus/Zoom control processor (backup)

**Module T2** - a Prism/Frost control processor (backup )

**Product IDs** - The menu is used to read the MAC Address, RDM UID and RDM Label.

**View Logs** - Use this menu to read fixture's data which have been recorded during fixture operation. This collected data allows easier troubleshooting.

**Fixture Errors** - Use this menu to read fixture errors which have occurred during fixture operation.

**Fixture States** - In the menu are recorded fixture states as power on and power off.

**Fixture Positions** - In the menu are recorded installation positions of the fixture:

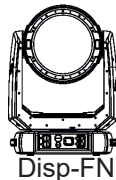

Disp-FN

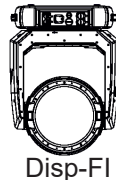

Disp-FI

**Fixture Temperatures** - In the menu are recorded temperatures which have exceeded defined levels.

**Sensor Logs** - In the menu item are recorded physical values in the fixture: temperature, relative humidity and pressure.

**Pressure Test Log** - In the menu item are recorded values related to executed pressure tests: date and time, temperature, pressure difference, duration of pressure test and its result.



## 10.3 Tab "Personality"



**DMX Preset Channels** - The menu item offers you overview of DMX channels used in the fixture.

**DMX Input**- Use the menu to select mode of DMX signal receiving.

**Wired** - DMX signal is received by means of the standard DMX cable.

**Wireless** - DMX signal is received by means of the inbuilt wireless module.

**Wireless In/XLR Out**- the fixture receives wireless DMX and sends the signal to its wired DMX output.

The fixture behaves as " Wireless/Wired" adapter.

The options "Wired" and "Wireless" are also stated in DMX chart (channel Power/Special functions).

Note. If the wireless module is not installed in the fixture, the following message will appear:

DMX Input Set to Wired

Wireless Module Missing

If the fixture is not connected to mains, the message "Not Available In Offline Mode" will appear after entering the menu DMX Input. To enter this menu, the fixture has to be connected to mains.

**Safety control**- Use the menu to switch the fixture to the Stage Mode or Sky Mode.

**SD Card** - Use the menu to disconnect SD card or format it.

**Pan/Tilt Settings** - Use the menu set behaviour of both pan and tilt movements.

**Pan Reverse** - The item allows to invert pan movement.

**Tilt Reverse** - The item allows to invert tilt movement.

**Pan/Tilt Feedback** - The item allows to return the moving head to the required pan/tilt position after changing the position by an external force if this option is set on.

Note. Be careful, the Pan/Tilt Feedback should be permanent On, the option Off is not suitable for standard operation and the head of the fixture can be damaged!

**Pan/Tilt mode** - Use this menu to set the mode of the pan/tilt movement

**Time mode** – The pan and tilt will move with different speeds and they will come at the same time to the end point of their tracks (pan and tilt use their optimal speeds).

Time of the pan/tilt movement (25.5 sec. max.) is set by the channel "Pan/Tilt speed, Pan/Tilt time".

**Speed Mode** - Both Pan and tilt will move with the same speed as adjusted at the channel "Pan/Tilt speed, Pan/Tilt time".

**Pan/Tilt EMS** - Built-in electronic motion stabilizer ensures precise position of the fixture's head during its movement and also reducing its swinging when the truss shakes.

**Follow Spot Mode** - If the function is activated, the pan/tilt motors perform on lower power and the head position can be controlled manually. You can choose from three levels of the pan/tilt "consistency": **soft**, **medium** and **hard**.

Note: reset of pan/tilt will not be executed if the fixture is in the Follow Spot Mode.

**Blackout Settings** - Use the menu if you need to close the light output under certain conditions which are described below

**Blackout During MC** - Blackout during movement correction. Set this option On if you wish to close light output during the time when the head goes to its correct position from which has been changed by an external force.

**Active Blackouts** - Use this menu if you wish to close the light output during effect changes.

**Pan/Tilt Moving** - The menu item enables you to close light output while the pan/tilt DMX values are changing.

**Gobo Wheel Moving** - The menu item enables you to close light output while gobo wheel is moving.

**Frequency Setup** - The function allows you to set the PWM (Pulse Width Modulation) output frequency of LEDs to 300Hz, 600Hz, 1200Hz or 2400Hz.

**Frequency Adjust** - The menu item allows you fine adjustment of the LED frequency around selected frequency.

**Auto Parking Pos.** - Automatic parking position. When this option is enabled, the fixture will automatically move to the Parking position whenever it is powered on and a DMX signal is missing or all DMX values are 0. Once a DMX signal is present, the Parking position will be automatically disabled. The menu "Manual Effect Control" in the tab "Manual Control" is inactive.

Note "Examples of screens with enabled Auto Parking Position.

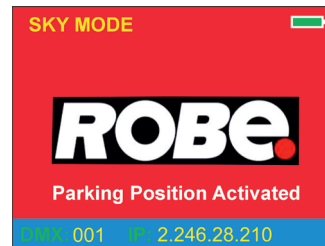
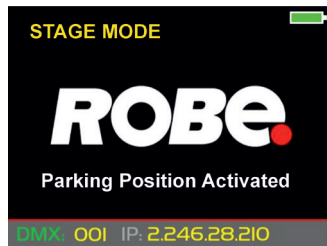

Function Parking position (channel 7, DMX values 126-129) moves the pan and tilt to the position (including movement of zoom to the front part of the head) in which the fixture head will always face down. Owing this position of the fixture head, there is not chance to burn internal parts of the head by the sun light.

**Init Effect Positions** - Use the menu to set all effects to the desired positions at which they will stay after switching the fixture on without DMX signal received.

**Reset Init Effect Pos.** - Use the menu to set all effects to the default (factory) positions.

**Screen Settings** - Use this menu to change the screen settings.

**Display Intensity** - The item allows to control the intensity of the screen (1-min., 10-max.).

**Screen saver Delay** - The item allows you to keep the screen on or to turn it off automatically after 1-10 minutes after last touch (or pressing any button on the control panel).

**Touchscreen Lock** - The item allows you to lock the screen after last touch (or pressing any button on the control panel). The time delay can be set in range of 1-10 minutes. To unlock the screen, press the [ENTER/Display On] button.

**Recalibrate Touchscreen** - The item starts calibration of the touch screen. Follow the instructions on the screen (only screen with direct access to the touchscreen).

**Display Orientation** - The menu allows to change display orientation.

**Normal** - Standard display orientation if the fixture is placed horizontally (e.g. on the ground).

**Inverted** - Inverted orientation (needed if the fixture is hanging on the truss).

**Auto** - The option activates a gravitation sensor for automatic screen orientation.

Note: **Auto** option is set as default. You change the display orientation by touching the icon  on the display, and the option set in the "Display Orientation" menu is temporarily overridden.

**Temperature unit** - Use the menu item to change temperature unit from °C to °F.

**Fan Settings** - Use the menu to set fans operation mode.

**Fan Mode** - Use the menu to set the fixture fans to max. power mode (option "**High**") or to the auto-control mode (option "**Auto**"). The third option "**Quiet**" allows you to set desired fan noise. The light output of the fixture is reduced at low speeds of fans.

**Quiet - Blackout Fan Off** - The menu item allows you to stop all fans in the fixture (option "**On**") when its light output is closed (shutter in range of 0-31 DMX or dimmer in 0 DMX).

**Dimmer Curve** - Use the menu to select desired dimmer curve: **Linear** or **Square Law**.

**Gobo Indexing** - The following three options define transition from gobo rotation to gobo indexing.

**Max. Speed & Shortcut** - Gobo goes from its rotation to desired indexed position with max. speed and via shortest track.

**Follow Speed & Direction** - Gobo goes from its rotation to desired indexed position with current speed and keeps a direction of rotation.

**Max. Speed & Follow Dir.** - Gobo goes from its rotation to desired indexed position with max. speed and keeps a direction of rotation.

**Date & Time Settings** - Use this menu to set current date and time for the fixture log system (menu "View Logs"). Set this menu items before first fixture operation.

**Default Settings** - The menu item allows to set all fixture parameters in this menu to the default (factory) values except item "DMX Input". Fixture is set to the Stage Mode, Auto Parking Position is enabled and dimmer is locked. i

**Memory Tools** - the menu item SD card allows you to allows you to do operations with SD card.

**SD card** - Internal SD card in the fixture base.

**SD State** - The menu item shows state of internal SD card

**Mount SD** - The menu item allows you to mount internal SD card to the system.

**Unmount SD** - The menu item allows you to unmount internal SD card from the system.

**Format SD** - The menu item allows you format internal SD card. The card has to be mounted to the system before formatted it.

**Password Protection** - allows to enter password in order to prevent unauthorized person from changing setting of the fixture. Password is set to 7623 and cannot be changed.

**Reset Web Password** - The menu item allows you to reset a password for access to the REAP (default password: 2479, user: robe).

## 10.4 Tab "Manual Control"



**Reset Functions** - The menu allows to reset the fixture either per function modules or all modules together.

**Total System Reset** - The item resets all function modules.

**Pan/Tilt Reset** - The item resets pan and tilt.

**Colour Reset** - The item resets colour wheel and CMY system.

**Gobo Reset** - The item resets rotating gobo wheel and static gobo wheel.

**Optics/Prism/Frost Res.** - The item resets zoom, focus, prisms and a frost.

**Manual Effect control** - Use the menu to control all fixture channels by means of the control panel.

## 10.5 Tab "Service"



**Pressure Test** - The menu item runs a procedure which checks the IP65 integrity of the fixture. The fixture has to be connected to mains and the head temperature (at pressure sensor) cannot be higher than 30°C. The pressure test lasts about 10 minutes and can be run at earliest 8 minutes after closing light output (shutter closed) of the fixture. The pressure test can be repeated at earliest 2 minutes after last pressure test.

For more details of pressure test please see the chapter Checking the IP65 integrity of the fixture.

**Adjust DMX Values** - The menu allows you to set all effects to desired positions before fine calibration of the effects .

**Calibrations** - This menu enables fine calibration of fixture effects and download default calibration values.

**Calibrate Effects** - The menu allows the fine adjustment of effects.

**Pan**- a pan position fine adjustment (value range: 0-255)

**Tilt** - a tilt position fine adjustment (value range: 0-255)

**Static Gobo** - a fine movement of static gobo wheel (value range: 0-255)

**Rot. Gobo Wheel 1** - a carousel 1 of rotating gobos fine movement (value range: 0-255)

**R. Gobo Index 1/1** - a fine movement of the rotating gobo 1 (value range: 0-255)

**R. Gobo Index 1/2** - a fine movement of the rotating gobo 2 (value range: 0-255)

**R. Gobo Index 1/3** - a fine movement of the rotating gobo 3 (value range: 0-255)

**R. Gobo Index 1/4** - a fine movement of the rotating gobo 4 (value range: 0-255)

**R. Gobo Index 1/5** - a fine movement of the rotating gobo 5 (value range: 0-255)

- R. Gobo Index 1/6** - a fine movement of the rotating gobo 6 (value range: 0-255)
- R. Gobo Index 1/7** - a fine movement of the rotating gobo 7 (value range: 0-255)
- R. Gobo Index 1/8** - a fine movement of the rotating gobo 8 (value range: 0-255)
- R. Gobo Index 1/9** - a fine movement of the rotating gobo 9 (value range: 0-255)
- Prism 1** - a prism wheel 1 fine movement (value range: 0-255)
- Prism 1 Rot 1** - fine rotation of prism 1 on prism wheel 1 (value range: 0-255)
- Prism 1 Rot 2** - fine rotation of prism 2 on prism wheel 1 (value range: 0-255)
- Prism 1 Rot 3** - fine rotation of prism 3 on prism wheel 1 (value range: 0-255)
- Prism 2** - a prism wheel 2 fine movement (value range: 0-255)
- Prism 2 Rot 1** - fine rotation of prism 1 on prism wheel 2 (value range: 0-255)
- Prism 2 Rot 2** - fine rotation of prism 2 on prism wheel 2 (value range: 0-255)
- Prism 2 Rot 3** - fine rotation of prism 3 on prism wheel (value range: 0-255)
- Zoom** - a zoom module fine movement (value range: 0-255)
- Focus** - a focus module fine movement (value range: 0-255)
- Frost** - a frost module fine movement (value range: 0-255)
- Colour Wheel** - a colour wheel fine movement (value range: 0-255)
- Colour Cyan** - a cyan flag fine movement (value range: 0-255)
- Colour Magenta** - a magenta flag fine movement (value range: 0-255)
- Colour Yellow** - an yellow flag fine movement (value range: 0-255)

*Calibration of the effects via the control board*

1. Disconnect DMX controller from the fixture and enter the "Calibrate Effects" menu.
2. Use the [up arrow] and [down arrow] to find "Pan" and press [Enter] to enter the fine effect adjustment screen.
3. Set desired value and save it by touching the [confirm].
4. Repeat steps 2 and 3 for next item
5. After calibrating all effects, touch the [confirm] to save all adjusted values to the fixture.

Calibration protocol:

| <b>Effect</b>     | <b>Channel</b> |
|-------------------|----------------|
| Pan               | channel 38     |
| Tilt              | channel 39     |
| Static gobol      | channel 40     |
| Rot. Gobo Wheel 1 | channel 41     |
| R. Gobo Index 1/1 | channel 42     |
| R. Gobo Index 1/2 | channel 43     |
| R. Gobo Index 1/3 | channel 44     |
| R. Gobo Index 1/4 | channel 45     |
| R. Gobo Index 1/5 | channel 46     |
| R. Gobo Index 1/6 | channel 47     |
| R. Gobo Index 1/7 | channel 48     |
| R. Gobo Index 1/8 | channel 49     |
| R. Gobo Index 1/9 | channel 50     |
| Prism 1           | channel 51     |
| Prism 1 Rot. 1    | channel 52     |
| Prism 1 Rot. 2    | channel 53     |
| Prism 1 Rot. 3    | channel 54     |
| Prism 2           | channel 55     |
| Prism 2 Rot. 1    | channel 56     |
| Prism 2 Rot. 2    | channel 57     |
| Prism 2 Rot. 3    | channel 58     |
| Zoom              | channel 59     |
| Focus             | channel 60     |
| Frost             | channel 61     |
| Colour wheel      | channel 62     |
| Cyan              | channel 63     |
| Magenta           | channel 64     |
| Yellow            | channel 65     |

**Calibrate Pan/Tilt EMS** - The menu item allows calibration of the pan/tilt electronic motion stabilizer.

Important: during this calibration any external force must not influence the fixture and the surface at which the fixture stands (or truss if the fixture hangs) has to be without movement, shake, strokes etc.

**Calibrate Pan/Tilt Reset** - The menu item is used for calibration of pan/tilt reset in factory and also has to be used in case of changing of pan or tilt motor or pan/tilt control PCB (RB3139 in the fixture yoke).

**Load Default Calibrations** - The item loads default (factory) calibration values.

**Rotating Gobos Change** - This menu makes changing of rotating gobos in the fixture easier.

**Gobo Carousel 1** - The menu allows movement of rotating gobos on the gobo carousel 1 to positions suitable for their changing.

**G1-Mg** - a movement of the gobo 1 (gobo holder with magnet) to the changing position.

**G2** - a movement of the gobo 2 to the changing position.

.

**Gobo Offset** - a gobo offset setting. The function allows fine swivelling of the gobo holder. The set value is valid for all gobos on the gobo carousel.

## 11. Software update

For software update of the fixture serves Robe Toolkit. The Robe Toolkit is a universal tool for Robe fixtures which includes Device Updater, Library Manager, Device Manager and simple DMX controller.

Please see the Toolkit user manual for more details about fixture update.

Software update of the iBolt cannot be done by means of standard Robe Uploader software.

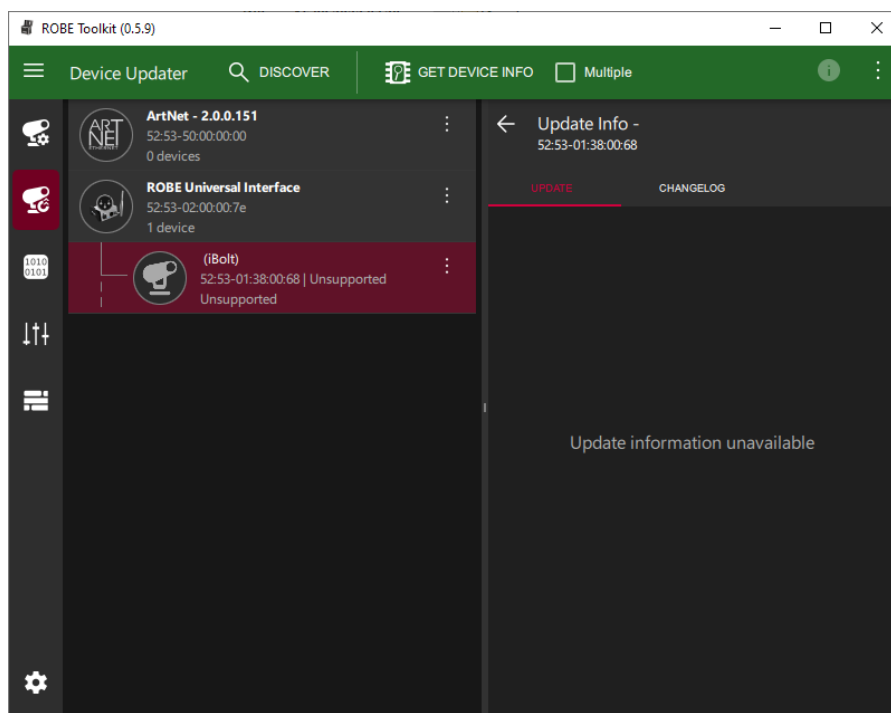

## 12. RDM

This fixture supports RDM operation. RDM (Remote Device Management) is a bi-directional communications protocol for use in DMX512 control systems, it is the new open standard for DMX512 device configuration and status monitoring.

The RDM protocol allows data packets to be inserted into a DMX512 data stream without adversely affecting existing non-RDM equipment. By using a special „Start Code,“ and by complying with the timing specifications for DMX512, the RDM protocol allows a console or dedicated RDM controller to send commands to and receive messages from specific moving lights.

RDM allows explicit commands to be sent to a device and responses to be received from it.

The list of commands for Robin iBOLT is the following:

| Parameter ID                | Discovery command | SET command | GET command |
|-----------------------------|-------------------|-------------|-------------|
| DISC_UNIQUE_BRANCH          | *                 |             |             |
| DISC_MUTE                   | *                 |             |             |
| DISC_UN_MUTE                | *                 |             |             |
| DEVICE_INFO                 |                   |             | *           |
| SUPPORTED_PARAMETERS        |                   |             | *           |
| SOFTWARE_VERSION_LABEL      |                   |             | *           |
| DMX_START_ADDRESS           |                   | *           | *           |
| IDENTIFY_DEVICE             |                   | *           | *           |
| DEVICE_MODEL_DESCRIPTION    |                   |             | *           |
| MANUFACTURER_LABEL          |                   |             | *           |
| DEVICE_LABEL                |                   | *           | *           |
| SENSOR_DEFINITION           |                   |             | *           |
| SENSOR_VALUE                |                   |             | *           |
| DISPLAY_INVERT              |                   | *           | *           |
| DISPLAY_LEVEL               |                   | *           | *           |
| PAN_INVERT                  |                   | *           | *           |
| TILT_INVERT                 |                   | *           | *           |
| DEVICE_RESET                |                   | *           |             |
| DMX_PERSONALITY             |                   | *           | *           |
| DMX_PERSONALITY_DESCRIPTION |                   |             | *           |
| STATUS_MESSAGES             |                   |             | *           |
| STATUS_ID_DESCRIPTION       |                   |             | *           |

RDM model ID for the Robin iBOLT is 0x0138.

## 13. Error and information messages

Error in the fixture is signalled by the yellow warning icon at the bottom line of the screen:



Use NEXT] or [PREV] button to highlight warning icon and press [ENTER] button to display error messages.

### **List of error and information messages:**

Note: capital letter X in the following messages means order of the effect in the fixture (e.g. Prism 1 Error 1 Prism 2 Error 1, and so on).

#### **Pan Error 1**

Mechanical end of the pan track was not detected.

#### **Pan Error 2**

Pan sensor error.

#### **Pan Error 3**

Pan feedback error.

#### **P/T Blackout Active**

Light output from the fixture was closed. This blackout was enforced by the following effect: pan or tilt.

#### **Pan Reset Active**

Pan reset is in progress and has not been fished yet.

#### **Tilt Error 1**

Mechanical end of the tilt track was not detected.

#### **Tilt Error 2**

Tilt sensor error.

#### **Tilt Error 3**

Tilt feedback error.

#### **Tilt Reset Active**

Tilt reset is in progress and has not been fished yet.

#### **P/T board EMS calibration needed**

The EMS system is not calibrated. Run the item "Calibrate Pan/Tilt EMS" in the tab "Service"

#### **Gyro board EMS calibration needed**

The EMS system is not calibrated. Run the item "Calibrate Pan/Tilt EMS" in the tab "Service"

#### **Cyan Error 1**

Magnetic/optic sensor was not detected.

#### **Cyan Error 2**

Magnetic/optic sensor permanently detects cyan flag.

#### **Cyan Blackout Active**

Light output from the fixture was closed. This blackout was enforced by the following effect: cyan flag.

#### **Cyan Reset Active**

Cyan flag reset is in progress and has not been fished yet.

#### **Magenta Error 1**

Magnetic/optic sensor was not detected.

**Magenta Error 2**

Magnetic/optic sensor permanently detects magenta flag.

**Magenta Blackout Active**

Light output from the fixture was closed. This blackout was enforced by the following effect: magenta flag.

**Magenta Reset Active**

Magenta flag reset is in progress and has not been fished yet.

**Yellow Error 1**

Magnetic/optic sensor was not detected.

**Yellow Error 2**

Magnetic/optic sensor permanently detects yellow flag.

**Yellow Blackout Active**

Light output from the fixture was closed. This blackout was enforced by the following effect: yellow flag.

**Yellow Reset Active**

Yellow flag reset is in progress and has not been fished yet.

**Colour Wheel X Error 1**

Magnetic/optic sensor was not detected on the colour wheel X.

**Colour Wheel X Error 2**

Magnetic/optic sensor permanently detects colour wheel X.

**CW X Blackout Active**

Light output from the fixture was closed. This blackout was enforced by the following effect: colour wheel X.

**CW X Reset Active**

Colour wheel X reset is in progress and has not been fished yet.

**Frost X Error 1**

Impact to the mechanical end of the frost X track was not detected.

**Frost X Error 4**

Incorrect detection of a frost X track. Impact to a mechanical obstruction was detected within running of the frost.

**Frost X Blackout Active**

Light output from the fixture was closed. This blackout was enforced by the following effect: frost module X.

**Frost X Reset Active**

Frost module X reset is in progress and has not been fished yet.

**Rot. Gobo Wheel X Err 1**

Magnetic/optic sensor of gobo carousel X was not detected.

**Rot. Gobo Wheel X Err 2**

Magnetic/optic sensor permanently detects gobo carousel X.

**RG Wheel X Blackout Active**

Light output from the fixture was closed. This blackout was enforced by the following effect: gobo carousel X.

**RG Wheel X Reset Active**

Gobo carousel X reset is in progress and has not been fished yet.

**Rot. Gobo X Err 1**

Magnetic/optic sensor was not detected on the rotating gobo on the gobo carousel X.

**Rot. Gobo X Err 2**

Magnetic/optic sensor permanently detects rotating gobo on the gobo carousel X.



**RG X Blackout Active**

Light output from the fixture was closed. This blackout was enforced by the following effect: gobo with magnet on the gobo carousel X.

**RG X Reset Active**

Gobo reset on the gobo carousel X is in progress and has not been fished yet.

**Static Gobo Err. 1**

Magnetic/optic sensor was not detected.

**Static Gobo Err. 2**

Magnetic/optic sensor permanently detects static gobo wheel.

**SG Blackout Active**

Light output from the fixture was closed. This blackout was enforced by the following effect: static gobo wheel.

**SG Reset Active**

Static gobo wheel reset is in progress and has not been fished yet.

**Zoom Error 1**

Impact to the mechanical end of the zoom track was not detected.

**Zoom Error 4**

Incorrect detection of a zoom track. Impact to a mechanical obstruction was detected within running of the zoom.

**F/Z Blackout Active**

Light output from the fixture was closed. This blackout was enforced by the following effect: zoom or focus.

**Zoom Reset Active**

Zoom reset is in progress and has not been fished yet.

**Focus Error 1**

Impact to the mechanical end of the focus module track was not detected.

**Focus Error 4**

Incorrect detection of a focus track. Impact to a mechanical obstruction was detected within running of the focus module.

**Focus Reset Active**

Focus reset is in progress and has not been fished yet.

**Prism X Wheel Error 1**

Impact to the mechanical end of the prism module X track was not detected.

**Prism X Wheel Error 4**

Incorrect detection of a prism module X track. Impact to a mechanical obstruction was detected within running of the prism module X.

**Prism Blackout Active**

Light output from the fixture was closed. This blackout was enforced by prism module(s).

**Prism X Wheel Reset Active**

Prism module X reset is in progress and has not been fished yet.

**Prism X Error 1**

Magnetic/optic sensor was not detected at prism wheel X.

**Prism X Error 2**

Magnetic/optic sensor permanently detects prism wheel X

**Prism X Reset Active**

Prism wheel X reset is in progress and has not been fished yet.

**MT sensor com Err**

Motion and temperature sensor (LIS2DTW12) does not communicate with a control processor.

**PROC X COMM ERR (e.g. PROC 2 COMM ERR)**

Internal communication error - some PCB in the fixture is faulty.

**Too Much Humidity in Device**

To remove the message, reset the bar chart Max.Wet in the menu RAINS Status (tab Information) and check the silica gel desiccants in the fixture arm.

**Valve Seal Error**

The valve in fixture arm or coil in the valve is defective or there is a connection problem between the valve and head, check cable connector at valve.

**Base Fan Error**

One or both fans in the fixture base are disconnected from their control PCB or are faulty and have to be replaced.

**P/T Fan Error**

Small fan in the fixture yoke is disconnected from its control PCB or is faulty and has to be replaced.

**Color Fan Error**

Small blower cooling colour wheel and gobo wheels in the fixture head is disconnected from its control PCB or is faulty and has to be replaced.

## 14. NFC

The fixture supports NFC (Near-Field Communication). Using the mobile phone application ROBE COM you can read and set the Robin iBOLT parameters (DMX address, IP address...etc.), get information about temperatures, operation hours, RDM identification etc.

The NFC point is situated on the front panel of fixture's base.

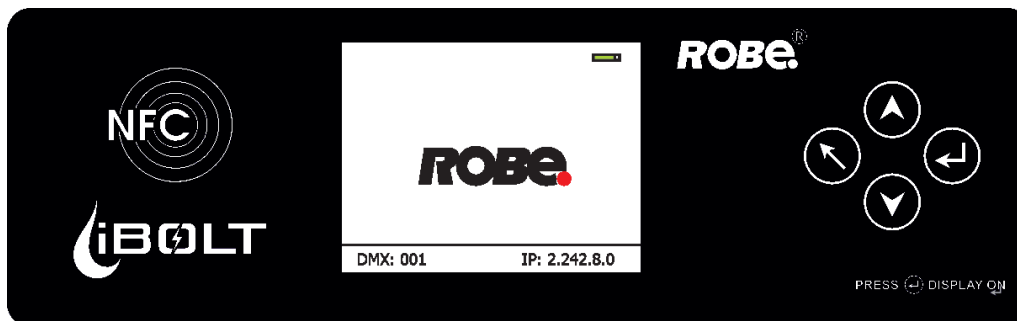

Download and install the ROBE COM from Google Play (for Android 5.0 and higher) or App Store (for iOS 12.0 and higher) to your mobile phone. Your mobile phone has to support NFC.

Hold the mobile phone on the side of the fixture base, if NFC connection is OK, discovered fixture will appear on the screen, after touching the fixture name the following menu items will appear:

- DMX/RDM settings
- Ethernet settings
- Blackout settings
- Colour settings
- Display settings
- Standalone settings
- Pan/Tilt settings
- Other settings
- Software versions
- Device hours
- Device temperatures

Touch desired menu item to enter its submenu.

## 15. Cleaning

### **DANGER !**

***Always disconnect the fixture from mains before starting any cleaning work.***

Regular cleaning will not only ensure the maximum light output, but will also allow the fixture to function reliably throughout its life.

The frequency of cleaning depends on the environment in which the fixture operates: damp, smoky or particularly dirty environments can cause greater accumulation of dirt on the fixture housing.

The front glass cover of the head will require cleaning on a monthly basis. A soft lint-free cloth dampened with a solution of water and a mild detergent is recommended, under no circumstances should alcohol, solvents or abrasives be used!

Stains caused by hard water (water that has high mineral content) can be effectively removed by means of non - abrasive descaler (e.g. EverStar descaler).

## 16. Maintenance

***Do not do maintenance in a damp environment (e.g. rain, snowfall)!***

**DANGER !**

***Always disconnect the fixture from mains before starting any maintenance work.***

In order to ensure the fixture remains in good condition and does not fail prematurely, we recommend regular maintenance.

The following points have to be considered during fixture inspection:

- All outside covers and screws should be checked for damages, scratches or corrosion.
- All connectors and its rubber caps should be checked for damages or sediments.
- All screws and fasteners has to be securely tightened. Check for any deformation on the housing and rigging points. Damaged rigging points or unsecured rigging could cause the fixture to fall and seriously injure people.
- Electric power supply cable must not show any damage or material fatigue.
- Fans and heatsink should be checked for sediments or dirt/debris accumulation.

User can do the following operations:

- Gobo replacement
- Silica gel desiccants replacement
- Main fuse replacement
- Battery replacement
- Lubrication of internal parts of the fixture

Another maintenance and service operations should be carried out by trained technician only. If you need any spare parts, please order genuine parts from your local Robe distributor.

In case of problem with smooth running of CMY colour mixing system, lubricate sliding bars of CMY flags. As lubricant we recommend ÅRONIX silicone oil 500 cSt - it is a medium viscosity lubricant, release agent, high temperature oil.

Fixture metal covers are made of material resistant to corrosion, potential damages of covers (like scratches, abrasions) are only appearance defects and will not cause corrosion of covers.

To repair small damages of fixture metal covers (e.g. scratches), you can use a paint intended for non-rusting metal surfaces (like aluminium, copper...). The paint can be applied to surface by means of a small brush or by spraying.

Use the paint with the same colour and sheen as has your cover. The paint can perform as undercoat or top-coat, it doesn't matter.

**Do not remove fixture covers in smoky or particularly dirty environment (e.g. with fog machines)**

**IMPORTANT** The fixture head should be uncovered as short time as possible (about 1-2 hours depending on air humidity) otherwise silica gel in small boxes in the fixture head may become damp.

If you have removed head cover and you need to interrupt your work for longer time (hours, days), we recommend to place the head cover on the head and fasten it provisionally by means of two screws, next possibility is unscrewing small boxes with silica gel from the head and put it to a sealed container with limited access of air (e.g. sealed plastic bag).

The same rule should be kept for silica gel desiccants in the fixture base in case of service intervention (at removing bottom base cover).

### **Replacing the fuse.**

Before replacing the fuse, disconnect the fixture from mains.

1. Using a flat-blade screwdriver, unscrew (anti-clockwise) the metal cover of the fuse compartment from the rear panel of the base.
2. Unscrew the fuse holder (anti-clockwise) and remove the blown fuse from the fuse holder.
3. Place a good fuse (only the same type and rating) into the fuse holder and screw the fuseholder back.
4. Screw the metal cover of the fuse compartment back to the rear panel, use a tightening torque 2.5Nm.

### Replacing the battery.

Before replacing the battery, disconnect the fixture from mains.

1. Using a flat-blade screwdriver, unscrew (anti-clockwise) the metal cover of battery compartment from rear panel of the base.
2. Loosen (anti-clockwise) the battery holder cap.
3. Remove the exhausted battery from the battery holder.
4. Place a new battery (only the same type) into the battery holder (Negative (-) inside, Plus (+) outside).
5. Place back the battery holder cap and tighten it.
6. Screw the metal cover of battery compartment back to the rear panel of the base, use a tightening torque 2.5Nm .

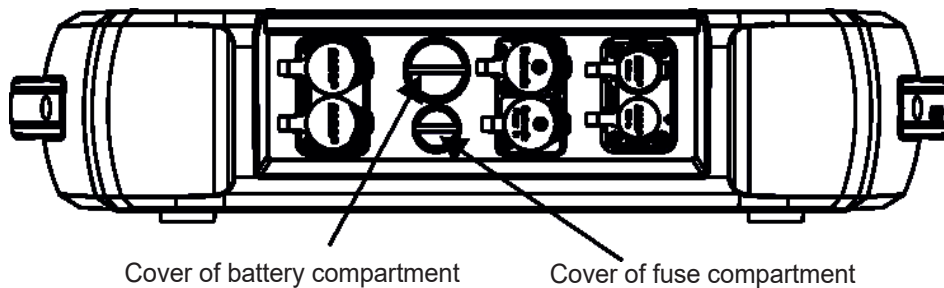

### Changing pan/tilt motors or pan/tilt driver.

In case of change of pan motor or tilt motor or pan/tilt control PCB (RB 3138 in the fixture yoke), you have to run the procedure Calibrate Pan/Tilt Reset in the tab "Service" (tab Service--> Calibrations --> Calibrate Pan/Tilt Reset)

## 16.1 Fixture watertight covers and torques of covers screws

Keep values of torques as stated on pictures below otherwise leakage issues can occur!

*Run the procedure Pressure Test (Service --> Pressure Test) after replacing any watertight cover!*

### Bottom base cover

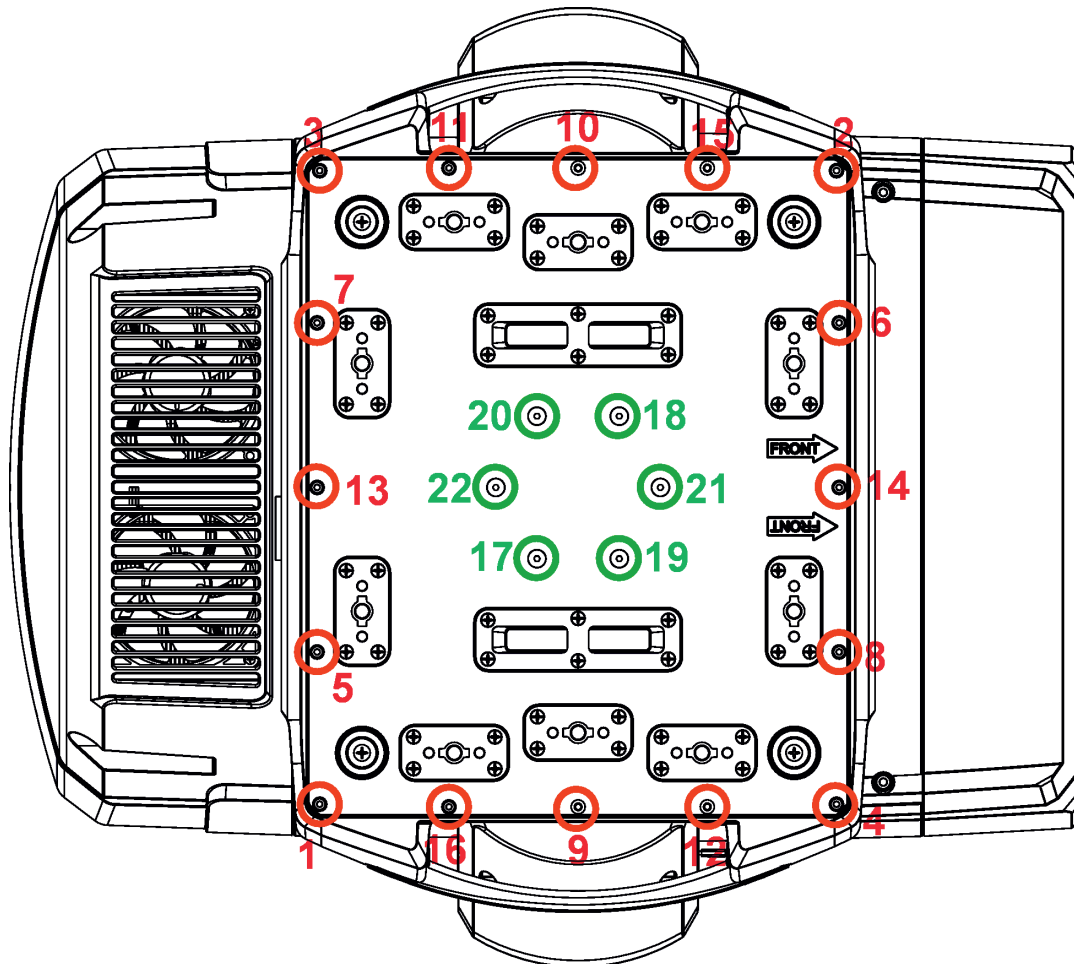

Screws must be tightened  
in the order 1-->16  
17-->22.

- 16 x hex socket head screw M4x14  
Tightening torque\*: 2.5 Nm
- 6 x flat head screw M5x18 with rubber ring  
Tightening torque\*: 2.5 Nm

\* Tighten all screws in two steps:  
Step 1 - use tightening torque 0.5Nm (pre-tightening)  
Step 2- use tightening torque 2.5Nm (final tightening)

**Carefully check the gasket for signs of deformities or damages and if it is correctly placed before screwing the bottom base cover back. The gasket is part of the base.  
Do not forget to connect grounding wire between chassis and base cover.**

## Head covers (on both sides of the head)

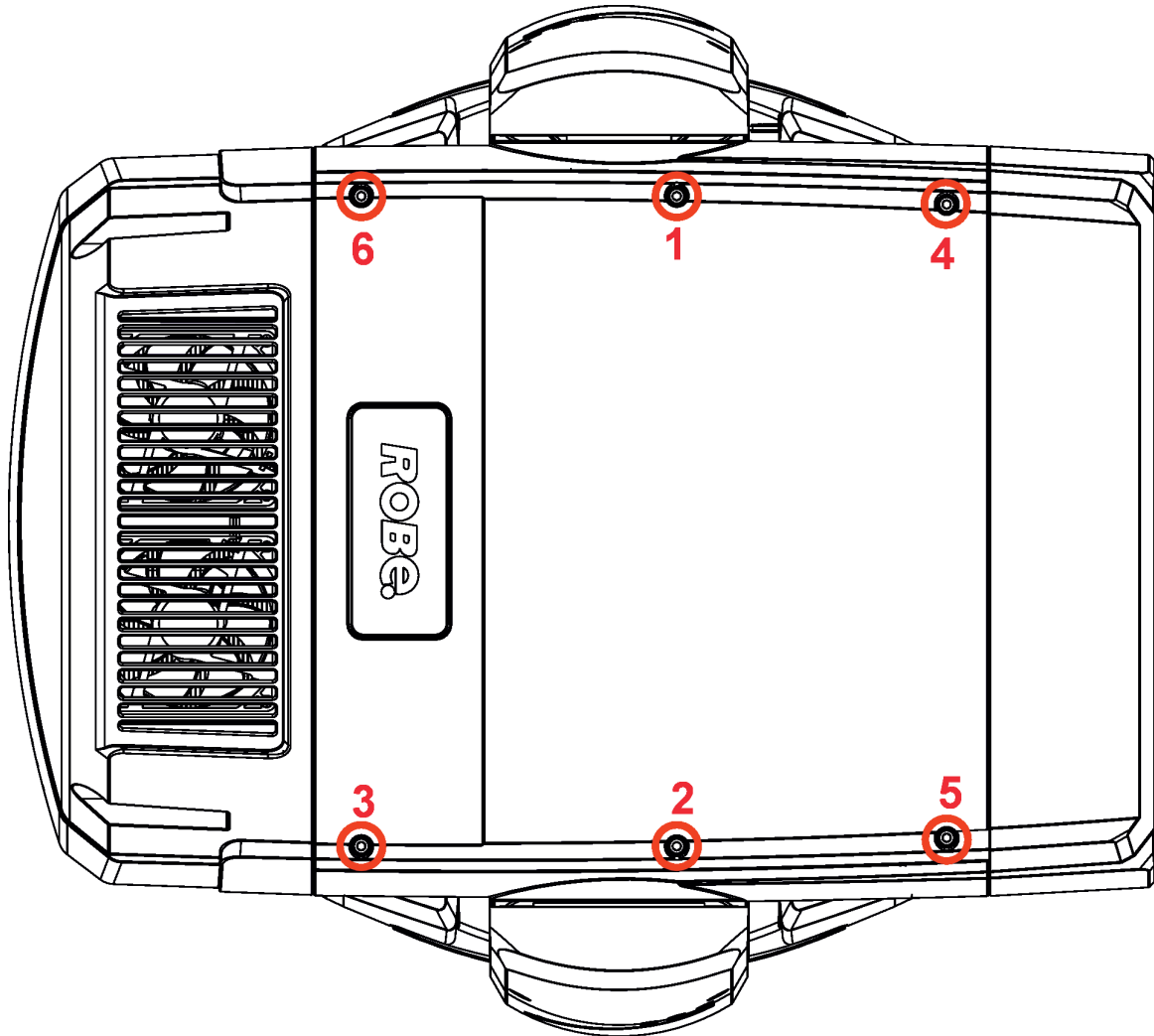

Screws must be tightened  
in the order 1-->6

6 x hex socket head screw M5x16  
Tightening torque\*: 2.5 Nm

\* Tighten all screws in two steps:

Step 1 - use tightening torque 0.5Nm (pre-tightening)

Step 2- use tightening torque 2.5Nm (final tightening)

**Carefully check the gasket for signs of deformities or damages and if it is correctly placed before screwing head covers back. The gasket is part of the head cover.**

**Do not forget to connect grounding wire between chassis and head cover.**

## Yoke cover

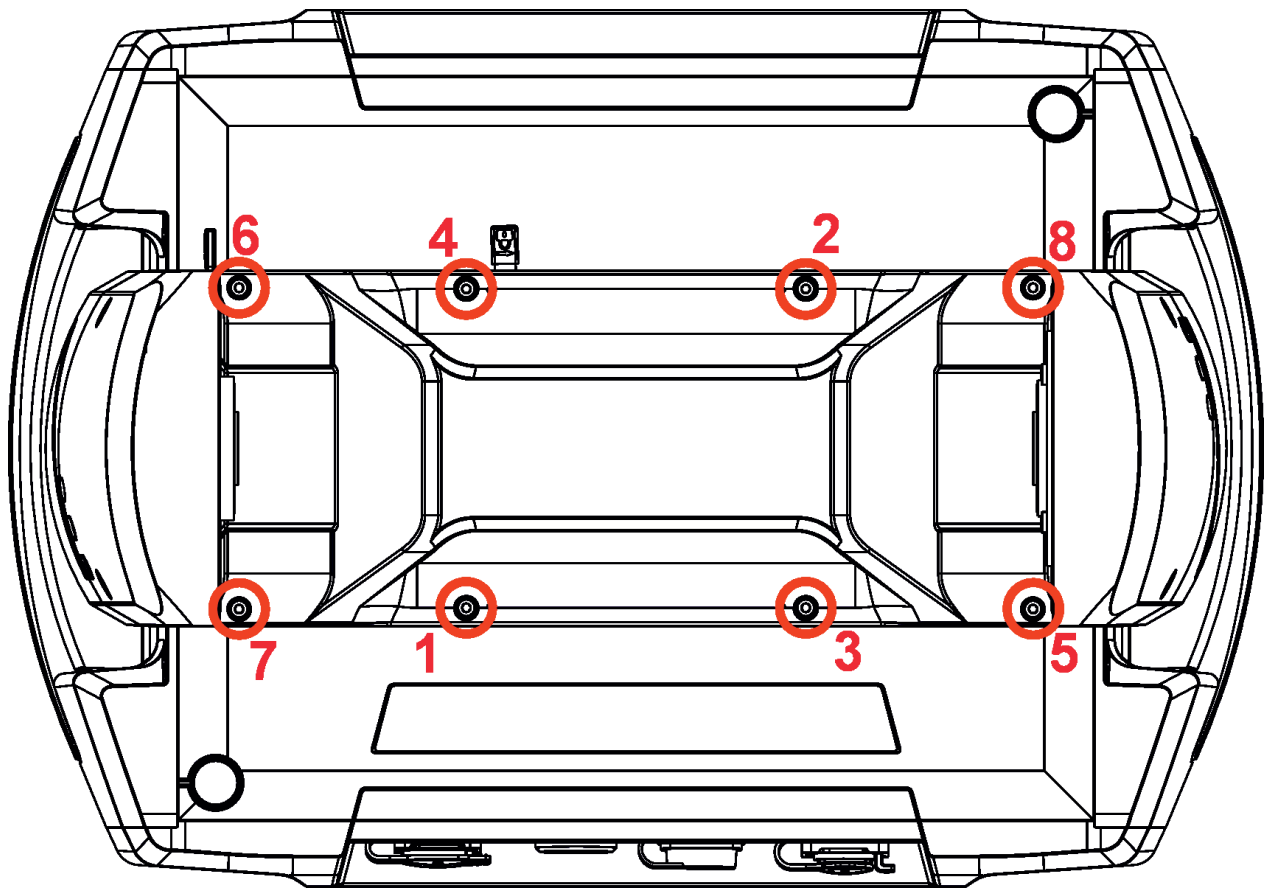

Screws must be tightened  
in the order 1-->8,

8 x hex socket head screw M4x8  
Tightening torque\*: 2.5 Nm

\* Tighten all screws in two steps:  
Step 1 - use tightening torque 0.5Nm (pre-tightening)  
Step 2- use tightening torque 2.5Nm (final tightening)

**Carefully check the gasket for signs of deformities or damages and if it is correctly placed before screwing the yoke cover back. The gasket is part of the yoke cover.  
Do not forget to connect grounding wire between chassis and yoke cover.**



## Cover of laser section

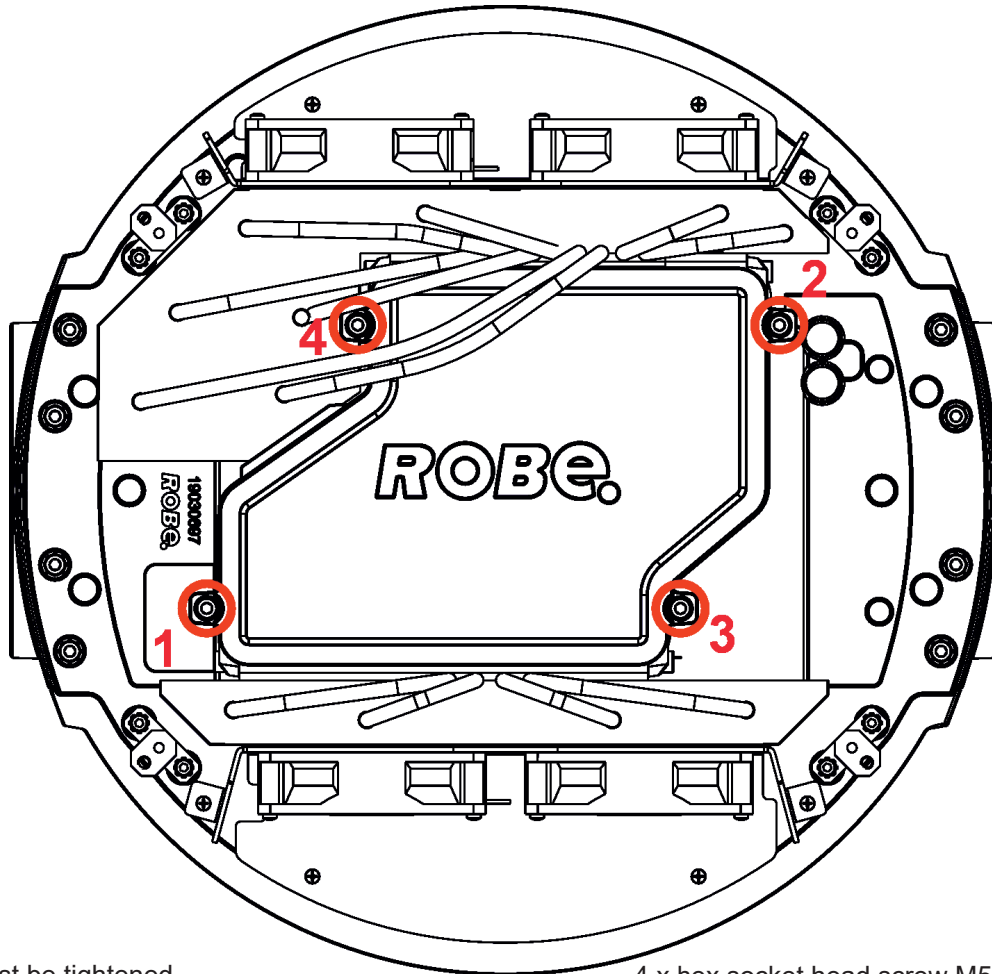

Screws must be tightened  
in the order 1-->4,

4 x hex socket head screw M5x12  
Tightening torque\*: 2.5 Nm

\* Tighten all screws in two steps:  
Step 1 - use tightening torque 0.5Nm (pre-tightening)  
Step 2- use tightening torque 2.5Nm (final tightening)

**Carefully check the gasket for signs of deformities or damages and if it is correctly placed before screwing the cover of laser source back. The gasket is part of the laser source cover.  
Do not forget to connect grounding wire between chassis and cover of laser source.**

## 16.2 Torques of Pan/Tilt motors screws

In case of change of pan motor or tilt motor or pan/tilt control PCB (RB 3138 in the fixture yoke), you have to run the procedure Calibrate Pan/Tilt Reset in the tab "Service" (tab Service--> Calibrations --> Calibrate Pan/Tilt Reset).

### Tilt motor

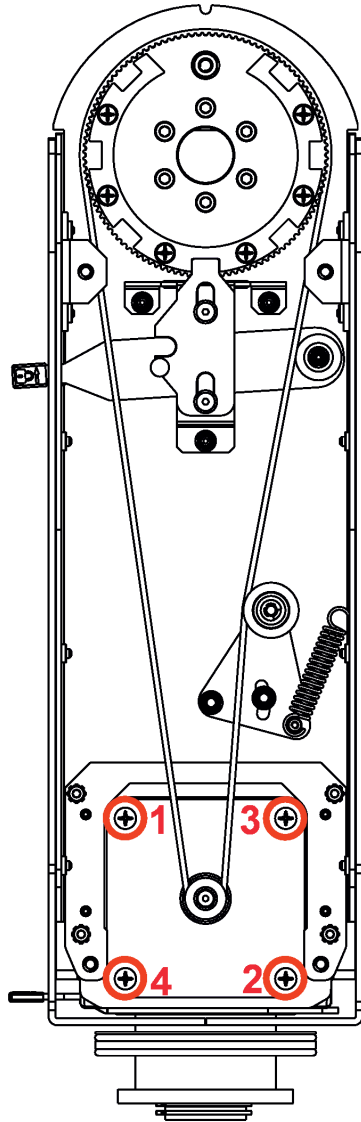

4 x flat head screw M5x16 (stainless)  
with sealing ring 5x1.5  
Tightening torque\*: 2.5 Nm

Screws must be tightened in the order 1-->4,  
Use LOXEAL 55.03 (nut locking threadsealing)  
on each screw

\* Tighten all screws in two steps:  
Step 1 - use tightening torque 0.5Nm  
(pre-tightening)  
Step 2- use tightening torque 2.5Nm  
(final tightening)

### Pan motor

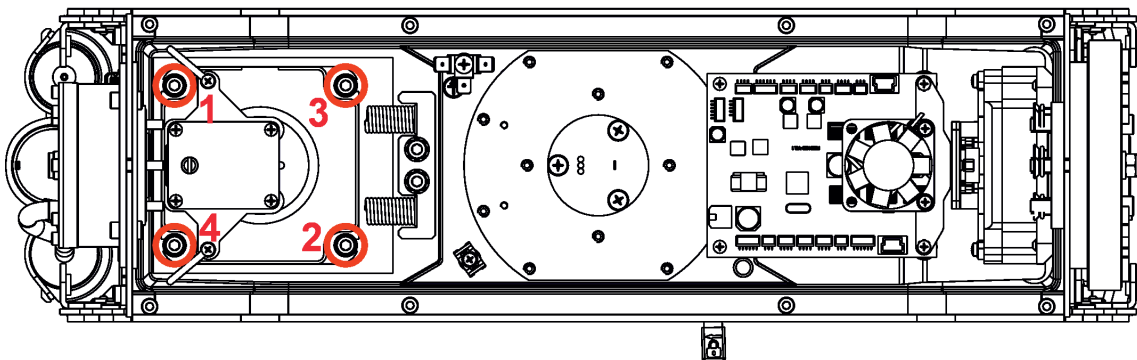

4 x hex socket head screw M5x20 (stainless) with  
washer  
Tightening torque\*: 2.5 Nm

Screws must be tightened in the order 1-->4.  
Use LOXEAL 55.03 (nut locking threadsealing)  
on each screw

\* Tighten all screws in two steps:  
Step 1 - use tightening torque 0.5Nm (pre-tightening)  
Step 2- use tightening torque 2.5Nm (final tightening)

## 16.3 Checking and replacing the silica gel desiccants

The silica gel desiccants are used for humidity indication in the fixture. Dry silica gel has an orange colour, if it is saturated with water, its colour changes to dark grey. If most of silica gel changed colour to dark grey, it has to be replaced.

***Unplug the fixture from mains before checking/replacing silica gel desiccant!  
Do not check/replace silica gel desiccant in a damp environment (e.g. rain, snowfall)!***

***Spare desiccants from factory are packaged in a protective foil. Take desiccants out of the protective foil immediately before replacing them in the fixture!  
Silica gel may become damp if it is exposed to wet air for longer time.***

***Silica gel is not under warranty!***

Desiccants are placed in the fixture on the following places:

fixture head - 2 x small box with silica gel

fixture arm (without tilt lock) - 2 x tube with silica gel

fixture base - 1 x small box with silica gel

Total weight of silica gel filling in the fixture is 350 g.

### Fixture head

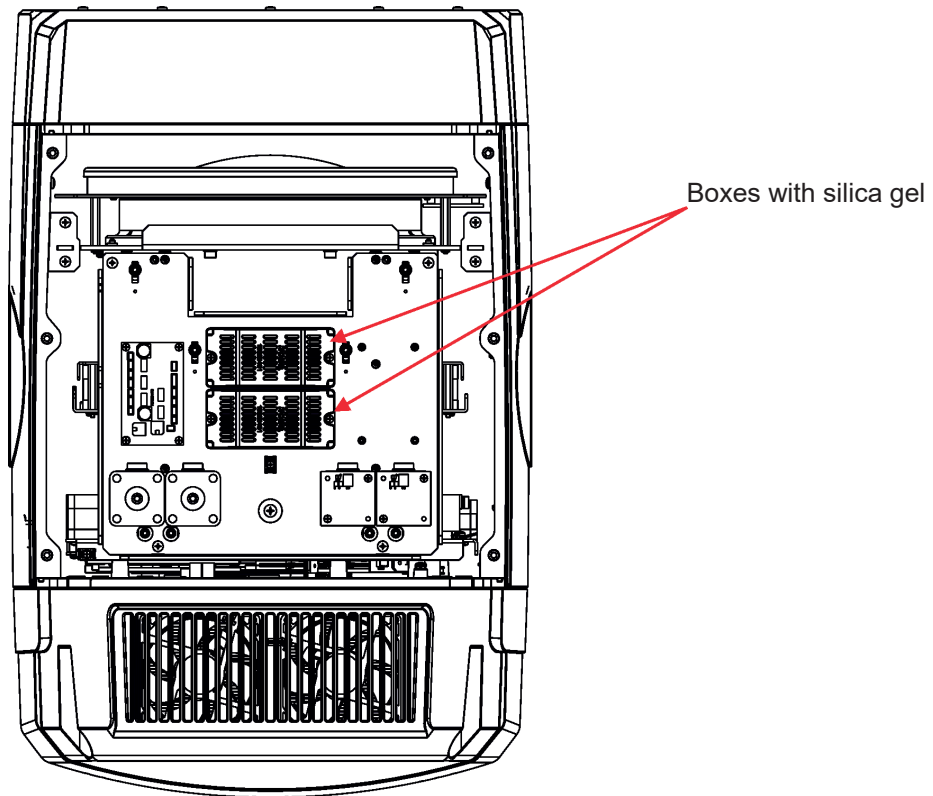

### Fixture base

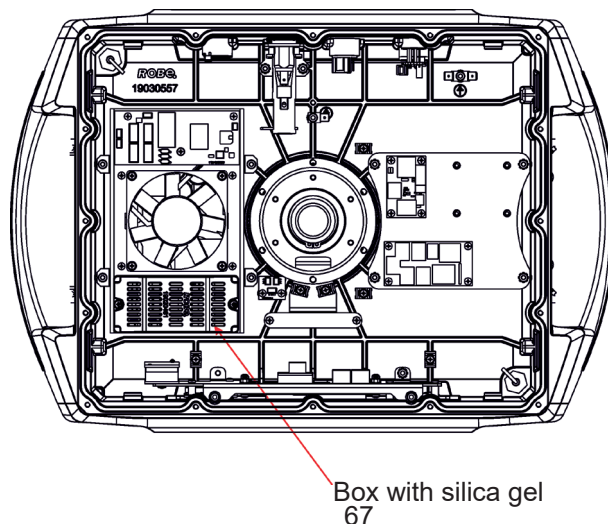

Box with silica gel  
67

Each silica gel box is fastened in the fixture by means of two screws.

Example:

Dry silica gel

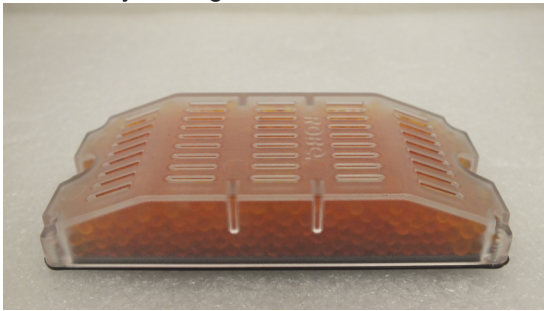

Silica gel saturated with water

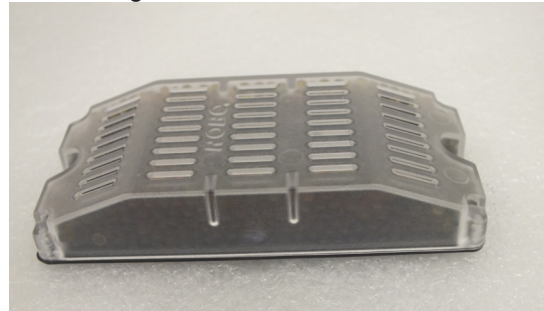

The silica gel desiccants in the fixture head should be checked (and alternatively replaced) at removing head covers, e.g. at gobos change.

The silica gel desiccants in the fixture base should be checked (and alternatively replaced) at removing bottom cover e.g. at service intervention.

**After checking/replacing boxes with silica gel do not forget to connect grounding wire between chassis and base cover (head cover) at placing the covers back.**

**After checking/replacing boxes with silica gel, run the procedure Pressure Test (Service -->Pressure Test).**

**If the pressure test is not OK, check if all screws of head covers (base cover) are correctly tightened.**

#### Fixture arm

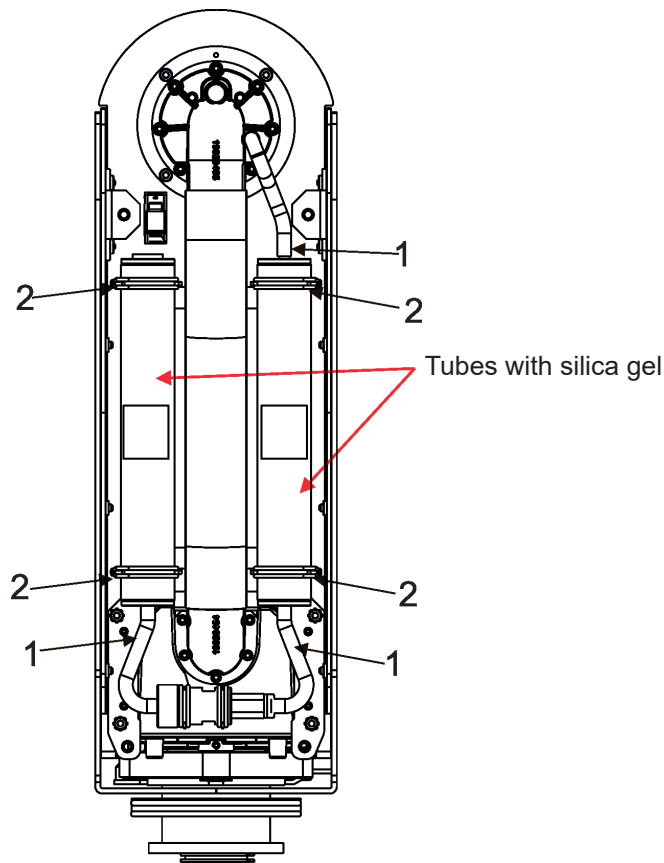

To change the tube with silica gel:

1. Disconnect the fixture from mains.
  2. Remove the arm cover.
  3. Disconnect the hosepipe(s) (1) from the tube with silica gel.
  4. Stick out the rubber rings (2) and remove the tube with silica gel.
  5. Insert the new tube with silica gel and secure it by means of the rubber rings (2).
  6. Connect the hosepipe(s) (1) to the tube with silica gel.
  7. Screw the arm cover back.
  8. **After connecting the fixture to mains, reset the MAX WET chart (tab Information-->RAINS Status) and run the procedure Pressure Test (tab Service -->Pressure Test).**
- If the pressure test failed, check if hose-pipes are correctly put on the tubes with silica gel.

Example of dry silica gel and silica gel saturated with water:

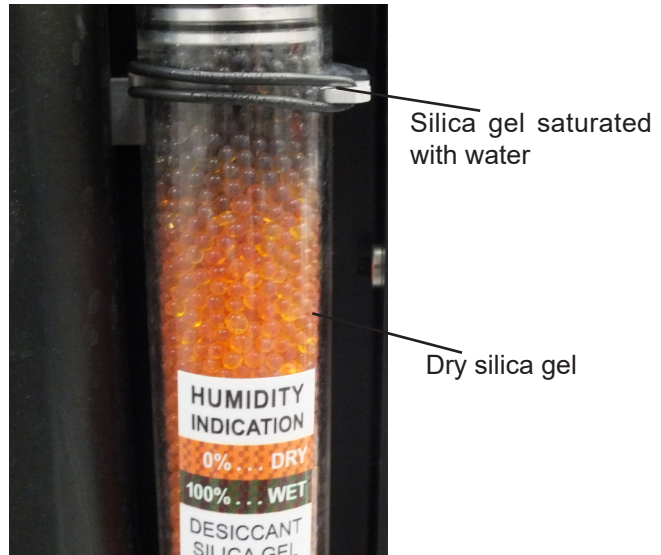

- State of desiccants in the fixture arm can be checked:
- visually by unscrewing the cover of fixture arm
- via fixture display (tab Information, option RAINS Status):

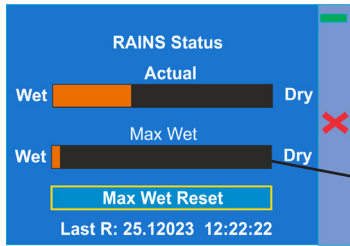

- remotely by means of the Robe Ethernet Access Portal (REAP):

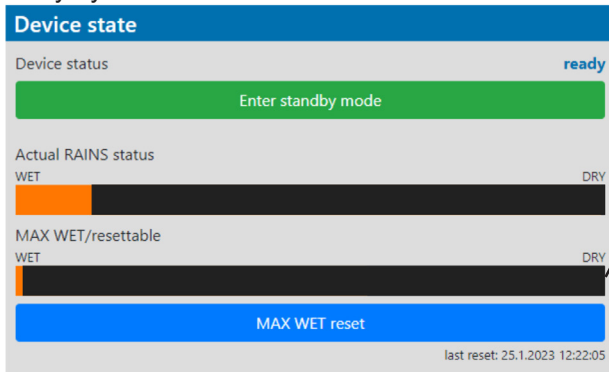

The chart MAX WET is decisive for replacing desiccants in the fixture arm. If the chart has changed to black colour, desiccants have to be replaced.

It is not necessary to replace silica gels desiccants in plastic boxes in the fixture head and base. These desiccants should be checked (and replaced if it is needed) at removing head or base covers, e.g. at gobo replacement or some service intervention.

In case that silica gel in the fixture arm is fully saturated with water, the warning message "**Too Much Humidity in Device**" will appear on the fixture display (yellow warning icon) and also in the Robe Ethernet Access Portal (Logs screen).

Example



## 16.4 Disposing of the product

To preserve the environment please dispose or recycle this product at the end of its life according to the local regulations and codes.

# 17. Robe Ethernet Access Portal (REAP)

Before running the REAP, your computer needs to be connected to the fixture (s) through the means of Ethernet wired network and a network switch. The computer needs to have configured network settings in order to be able to communicate with the fixture(s) through the network. The Ethernet network connection (Local LAN) typically needs to be set to 2.x.x.x address, the computer IP address has to be set to 2.x.x.x (for example 2.247.136.20) with netmask 255.0.0.0. On the fixture make sure to use the default 2.x.x.x IP address as provided. You do not need change any IP settings on the fixture, there is no need to set the fixture into Art-Net mode.

Type the IP address of the Robin iBOLT to your web browser, e.g. http://2.248.16.0, enter the user name: **robe** and the password: **2479**, the **Status screen** of the Robin iBOLT will appear.

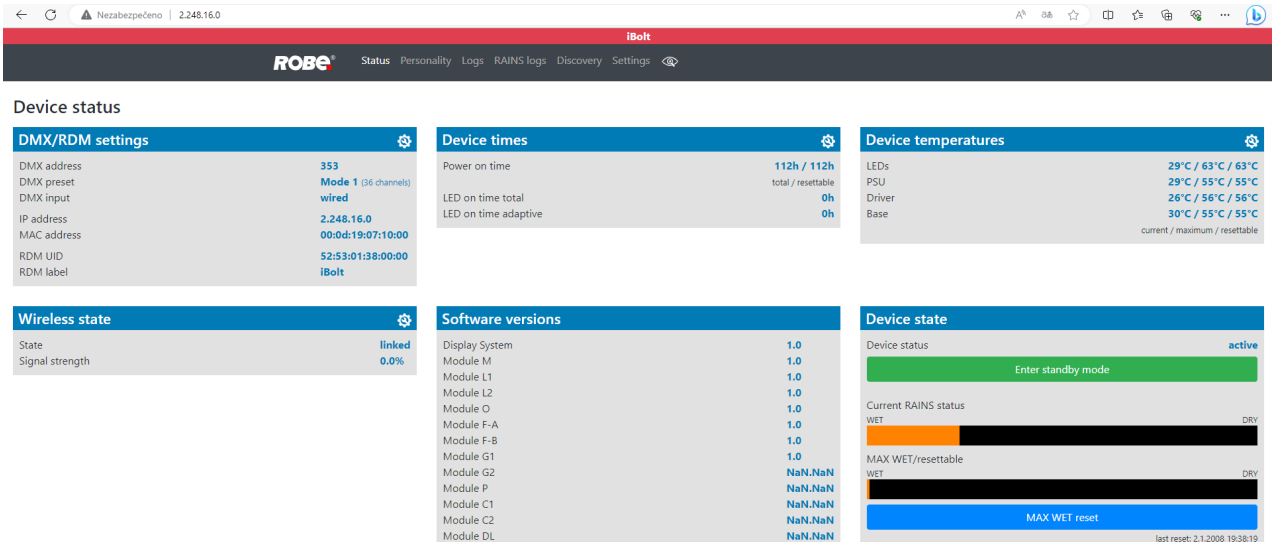

This screen gives you a fast overview of fixture settings and environment in the fixture. The icon  allows you to change some values in a corresponding table.

Example for DMX/RDM settings:

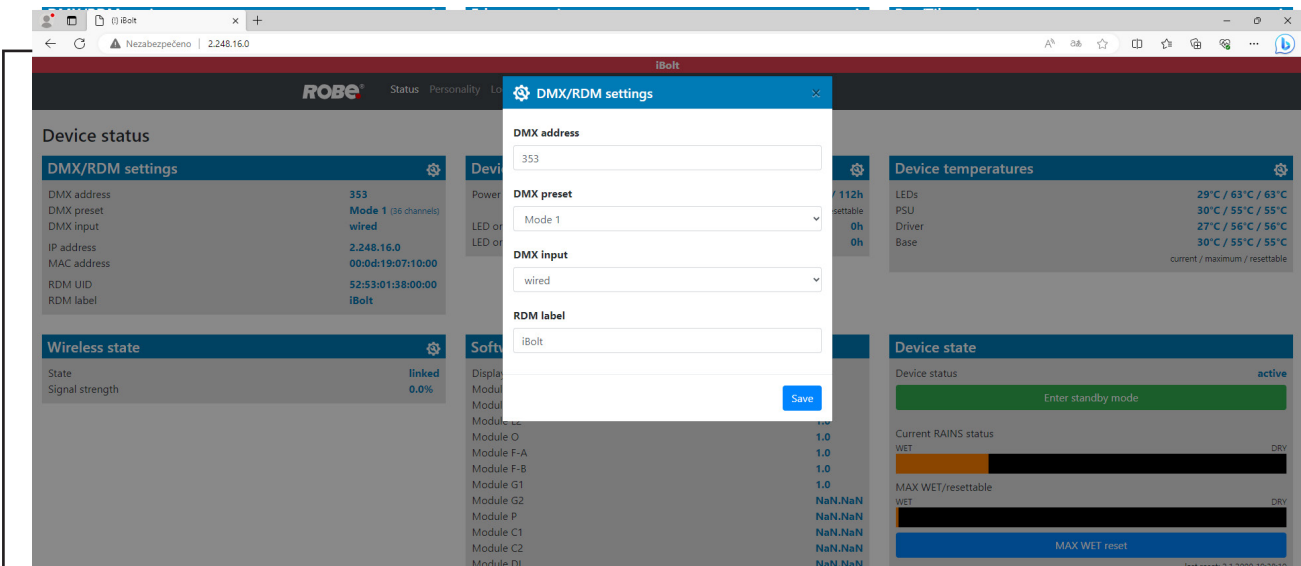

Note.

The background colour of the top row of the Status screen with the name and RDM label of the fixture denotes state of the fixture:



fixture is ready for operation

fixture does not communicate with computer

fixture with error message(s)

The table "Device state" gives you information about fixture and environment in the fixture.

Device status: **ready** - all fixture resets successfully passed and the fixture is ready for operation.

**initialization** - fixture is waiting for fixture reset

**heating** - fixture is waiting for reaching operating temperature of the fixture inside (temperature in the fixture is below 0°C).

**standby** - the fixture is in standby mode

**standby/heating** - the fixture is in standby mode and inside of the fixture is heated

The bar chart **Actual RAINS status** informs you about current humidity in the fixture. The bar chart changes depending on humidity, temperature and pressure in the fixture. The bar chart depends on current conditions in the fixture and can be different at start of fixture operation, after 10 minutes of its operating, after closing fixture dimmer etc.

RAINS (Robe Automatic Ingress Neutralization System) manages humidity, temperature and pressure control using an active monitoring system to automatically remove any moisture detected within the fixture and provides permanent monitoring to ensure peak performance of the fixture.

The bar chart **MAX WET/resettable** informs you about maximum humidity achieved in the fixture since the chart was last reset. The bar chart also informs you about saturation of silica gel desiccants in the fixture arm with water and is deciding indicator for their checking and replacement.

The blue button **MAX WET reset** resets the bar chart MAX WET/resettable. Date and time of last reset is displayed below this button.

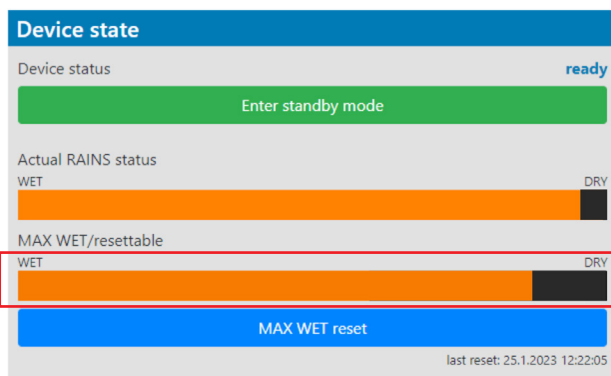

Silica gel desiccants in the fixture arm



Examples of the table "Device state":

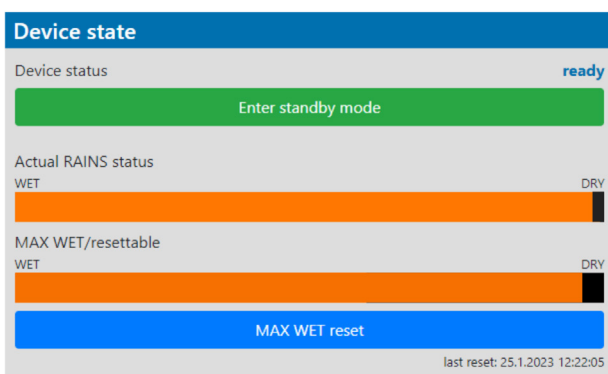

Dry desiccants

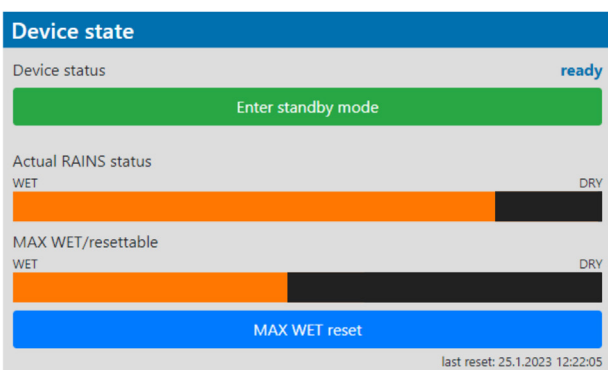

Desiccants partially saturated with water

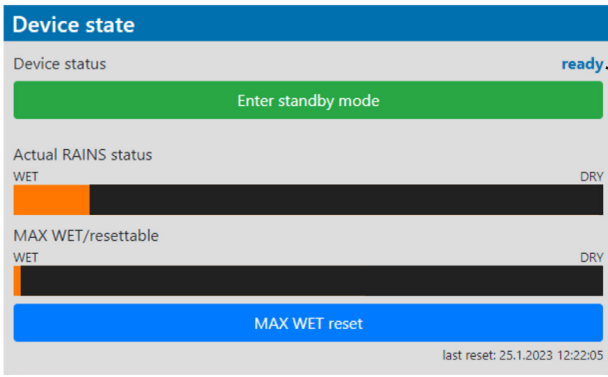

Device status **ready** means, that all fixture resets are OK and the fixture is ready for operation. It does not assess state of desiccants or result of pressure test!

**Desiccants fully saturated with water**

Silica gel desiccants in the fixture arm should be replaced.

**After replacing them, reset MAX WET resettable bar chart.**

It is not necessary to replace silica gels desiccants in plastic boxes in the fixture head and base. These desiccants should be checked (and replaced if it is needed) at removing head or base covers, e.g. at gobo replacement or some service intervention.

The option **Enter standby mode** allows you to switch the fixture to Standby mode.

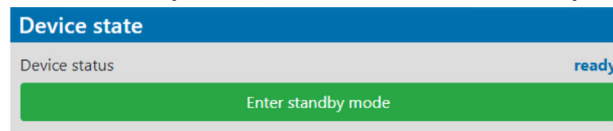

Note: Standby mode helps conserve power when a fixture is not in use, without fully powering it off. In the Standby mode, all fixture motors and fans are deactivated and light output is closed. For more information about Standby mode please see the chapter Standby mode.

The option **Escape standby mode** allows you to switch the fixture to standard operating mode.

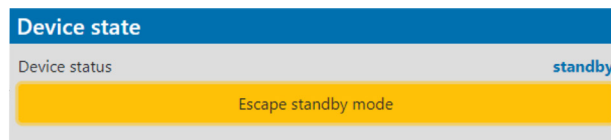



The **Personality** screen allows you to set fixture behaviour and run a pressure test.

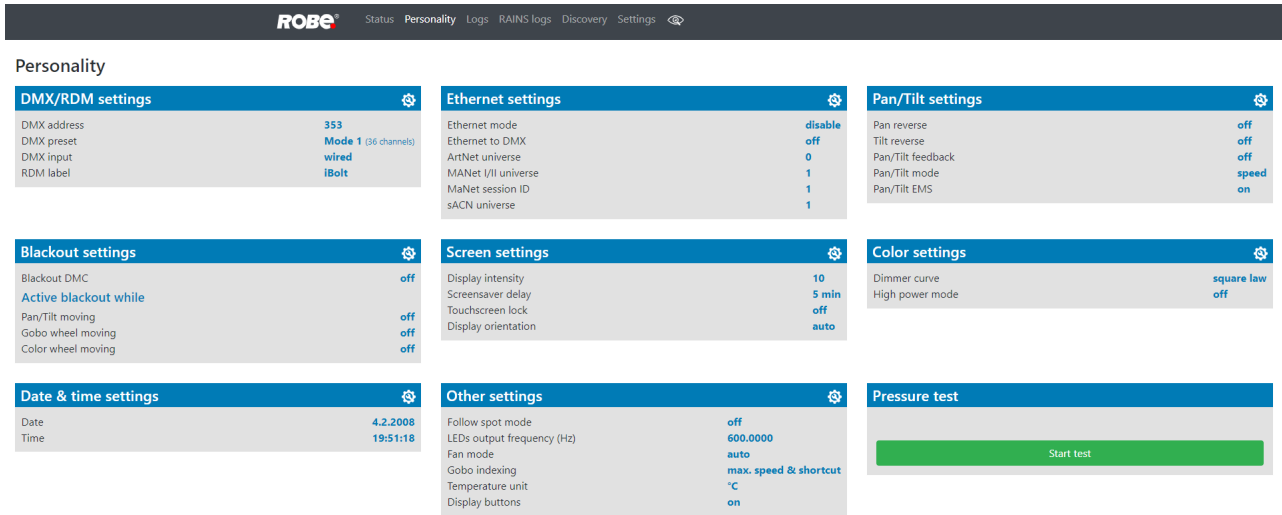

The icon  allows you to change values in a corresponding table.

Example for Pan/Tilt settings:

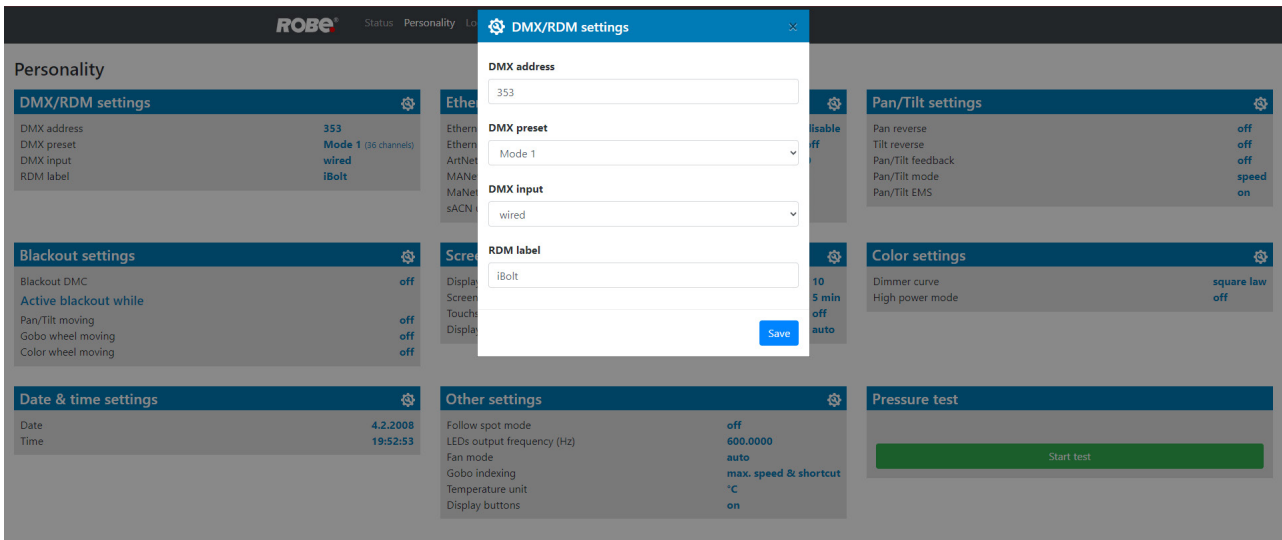

The table "Pressure test " with green button **Start test** allows you to run a procedure which checks IP65 integrity of the fixture. The fixture has to be connected to mains and the head temperature (at pressure sensor) cannot be higher than 30°C. The pressure test lasts about 5 minutes and can be run at earliest 10 minutes after closing light output (shutter closed) of the fixture. The pressure test can be repeated at earliest 2 minutes after last pressure test.

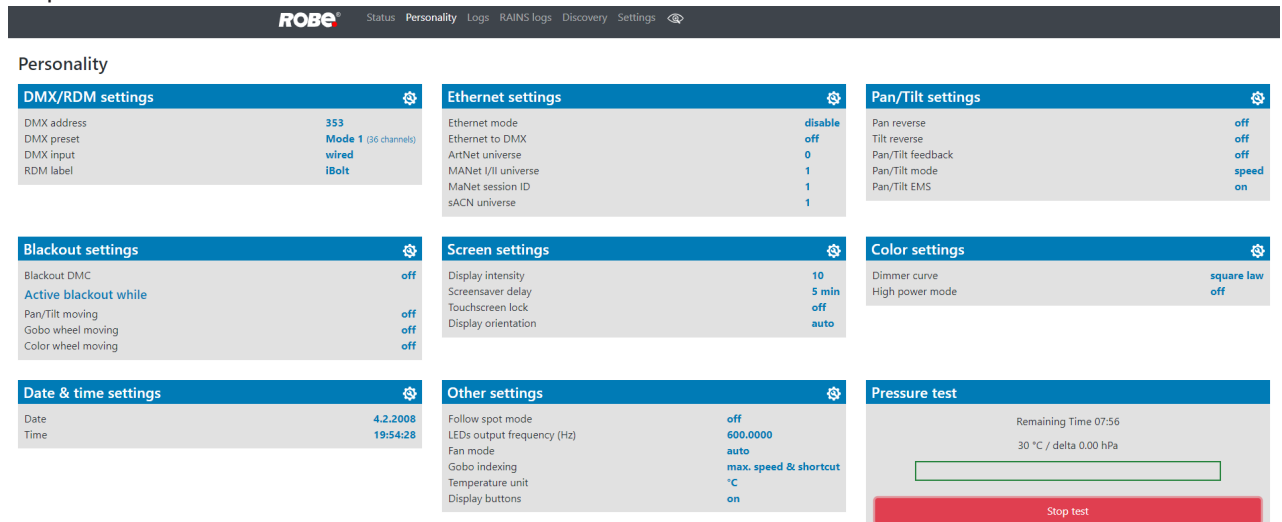

Examples of pressure test messages:

Pressure test is 10 minutes delayed due to fixture cooling

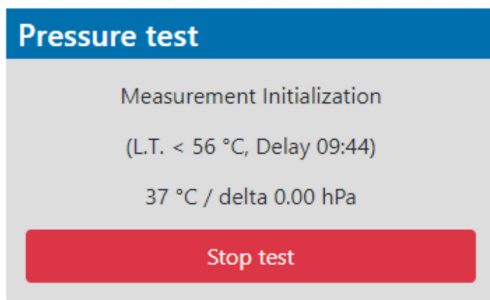

Pressure test is running

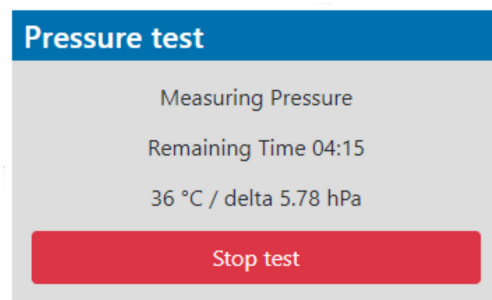

Pressure test passed

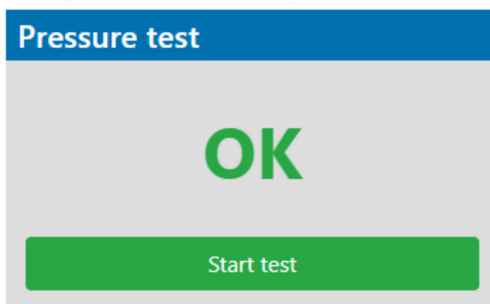

Pressure test failed

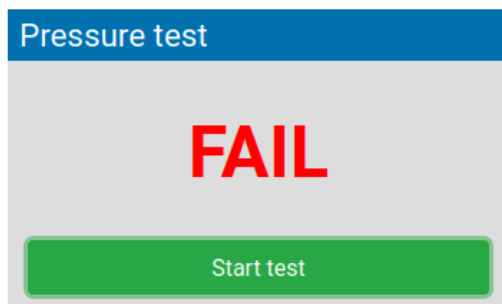

The **screen Logs** displays operating information of the fixture which have been saved.

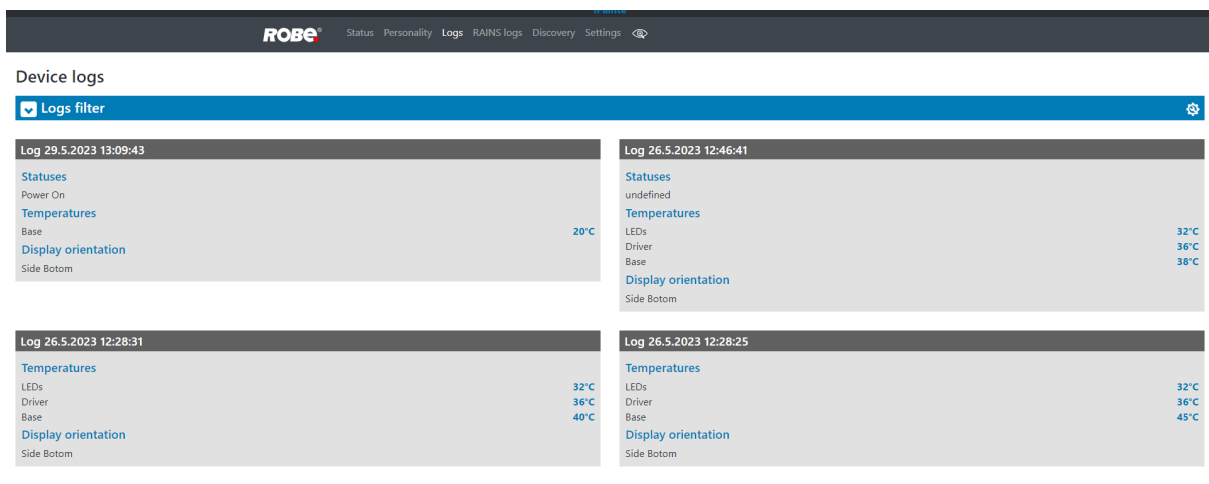

The icon  offers you two options:

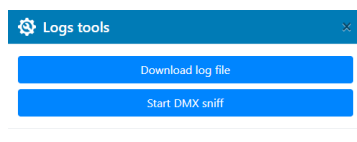

"Download log file" - the option allows you to download the log file to computer, name of the log file is: file-abcd.log, where abcd is a fixture ID (e.g. file-015e.log).

"Start DMX sniff" - the option starts saving coming DMX values to the file, the file name is DMX\_sniffer.log).

The option **Logs filter** allows you to select desired group of recorded errors and recorded operating values.

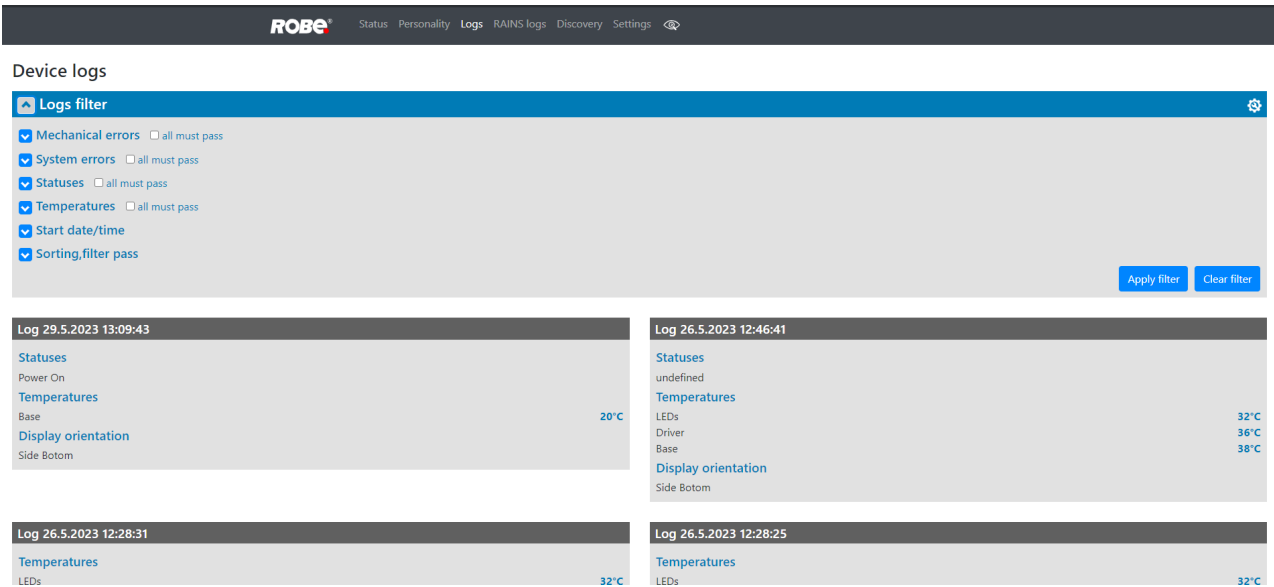

**Device logs**

**Logs filter**

- Mechanical errors  all must pass
- System errors  all must pass
- Statuses  all must pass
- Temperatures  all must pass
- Start date/time
- Sorting,filter pass

Apply filter Clear filter

**Log 29.5.2023 13:09:43**

Statuses  
Power On

Temperatures  
Base 20°C  
Display orientation  
Side Botom

**Log 26.5.2023 12:46:41**

Statuses  
undefined

Temperatures  
LEDs 32°C  
Driver 36°C  
Base 38°C  
Display orientation  
Side Botom

**Log 26.5.2023 12:28:31**

Temperatures  
LEDs 32°C

**Log 26.5.2023 12:28:25**

Temperatures  
LEDs 32°C

### Expanded menu **Logs filter**

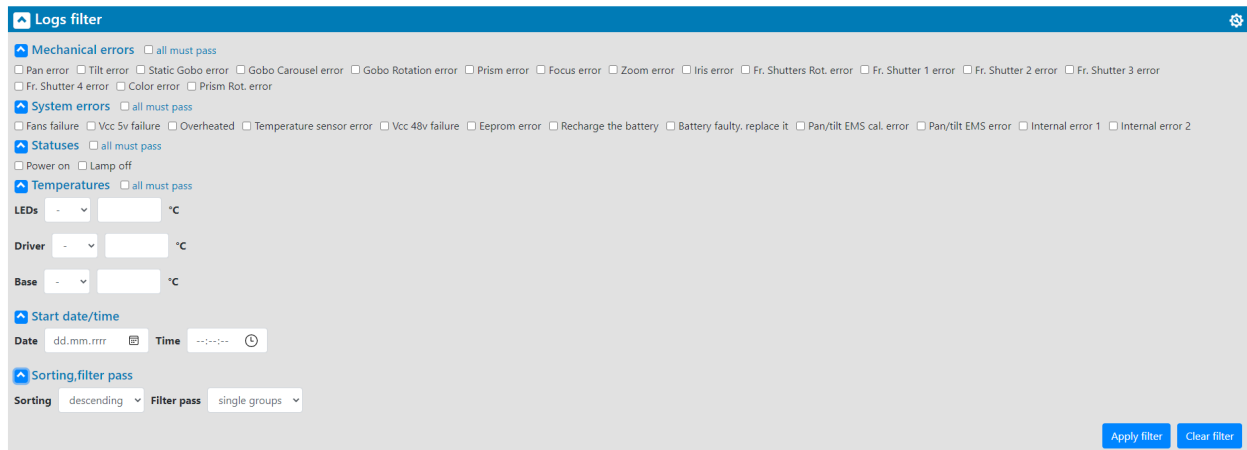

**Logs filter**

- Mechanical errors  all must pass
  - Pan error  Tilt error  Static Gobo error  Gobo Carousel error  Gobo Rotation error  Prism error  Focus error  Zoom error  Iris error  Fr. Shuttters Rot. error  Fr. Shutter 1 error  Fr. Shutter 2 error  Fr. Shutter 3 error  Fr. Shutter 4 error  Color error  Prism Rot. error
- System errors  all must pass
  - Fans failure  Vcc 5v failure  Overheated  Temperature sensor error  Vcc 48v failure  Eeprom error  Recharge the battery  Battery faulty, replace it  Pan/tilt EMS cal. error  Pan/tilt EMS error  Internal error 1  Internal error 2
- Statuses  all must pass
  - Power on  Lamp off
- Temperatures  all must pass
  - LEDs  °C
  - Driver  °C
  - Base  °C
- Start date/time
  - Date  Time
- Sorting,filter pass
  - Sorting  Filter pass

Apply filter Clear filter

If the option "all must pass" is checked, only logs which contain all selected errors will be displayed.  
 Menu "Sorting filter pass" --> option "single groups" means that logs which contain at least one selected error will be displayed.  
 Menu "Sorting, filter pass" option "all groups" means that logs which contain all selected error will be displayed.

The screen **RAINS Logs** offers you a list of physical values recorded by sensors inside the head.

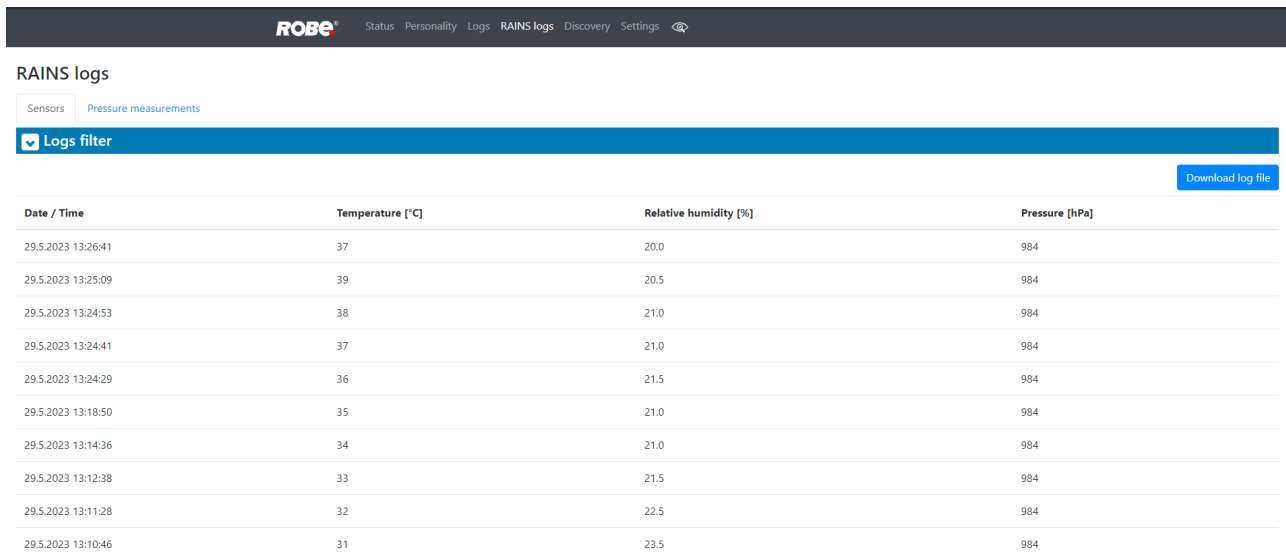

**RAINS logs**

Sensors Pressure measurements

**Logs filter**

Download log file

| Date / Time        | Temperature [°C] | Relative humidity [%] | Pressure [hPa] |
|--------------------|------------------|-----------------------|----------------|
| 29.5.2023 13:26:41 | 37               | 20.0                  | 984            |
| 29.5.2023 13:25:09 | 39               | 20.5                  | 984            |
| 29.5.2023 13:24:53 | 38               | 21.0                  | 984            |
| 29.5.2023 13:24:41 | 37               | 21.0                  | 984            |
| 29.5.2023 13:24:29 | 36               | 21.5                  | 984            |
| 29.5.2023 13:18:50 | 35               | 21.0                  | 984            |
| 29.5.2023 13:14:36 | 34               | 21.0                  | 984            |
| 29.5.2023 13:12:38 | 33               | 21.5                  | 984            |
| 29.5.2023 13:11:28 | 32               | 22.5                  | 984            |
| 29.5.2023 13:10:46 | 31               | 23.5                  | 984            |

You can select range of temperature, humidity and pressure in desired time interval.

The screenshot shows the 'RAINS logs' section of the interface. At the top, there are navigation links: 'Sensors', 'Pressure measurements', and 'Logs filter'. The 'Logs filter' panel includes fields for 'Start date' and 'End date' (both in 'dd.mm.yyyy' format), and dropdown menus for 'Temperature' (with a unit of °C), 'Relative humidity' (with a unit of %), and 'Pressure' (with a unit of hPa). There are 'Apply filter' and 'Clear filter' buttons. Below the filter panel is a 'Download log file' button. The main area contains a table with the following data:

| Date / Time        | Temperature [°C] | Relative humidity [%] | Pressure [hPa] |
|--------------------|------------------|-----------------------|----------------|
| 29.5.2023 13:26:41 | 37               | 20.0                  | 984            |
| 29.5.2023 13:25:09 | 39               | 20.5                  | 984            |
| 29.5.2023 13:24:53 | 38               | 21.0                  | 984            |

Tab Pressure measurements shows history of pressure tests.

The screenshot shows the 'Sensors' section with the 'Pressure measurements' tab selected. There is a 'Download measurements file' button. Below it is a table with the following data:

| Date / Time        | Temperature [°C] | Relative humidity [%] | Pressure [hPa] | Pressure difference [hPa] | Duration [m:s] | Result |
|--------------------|------------------|-----------------------|----------------|---------------------------|----------------|--------|
| 11.1.2023 14:59:17 | 47               | 8.5                   | 991            | 7.03                      | 03:26          | OK     |
| 10.1.2023 09:45:47 | 27               | 11.0                  | 988            | 7.28                      | 02:32          | OK     |

If you have two and more iBOLTs, the **Discovery** screen allows you to show all connected iBOLTs in network. Click on the blue button Discover and fixtures connected in the network will be displayed.

The screenshot shows the 'Discovery' screen. It has a 'Discover (4)' button and an 'Apply selection' button. Below these are checkboxes for column selection: DMX address, DMX preset, RDM UID, IP address, Head temperature [°C], Relative humidity [%], RAINS (max wet), Last pressure test, and Device status. The main table lists the following fixtures:

| Device            | DMX address | DMX preset            | RDM UID           | IP address   | RAINS (max wet) | Device status |
|-------------------|-------------|-----------------------|-------------------|--------------|-----------------|---------------|
| iBolt             | 353         | Mode 1 (36 channels)  | 52:53:01:38:00:00 | 2.248.16.0   | [Error icon]    | active        |
| iBeam 350         | 1           | Mode 1 (22 channels)  | 52:53:01:33:00:43 | 2.247.220.67 | [Warning icon]  | active        |
| iForte - iForte 3 | 1           | Mode 1 (54 channels)  | 52:53:01:2c:00:1a | 2.247.136.26 | [Warning icon]  | active        |
| iTetra2           | 1           | Mode 6 (128 channels) | 52:53:01:34:00:2a | 2.247.216.42 | [Warning icon]  | active        |

The background colour in the device row denotes state of the fixture:

- indicates "server fixture"(fixture of which IP address you have written to your WEB browser).
- indicates fixture ready for operation.
- indicates fixture which does not communicate with computer or "server fixture".
- indicates fixture with error messages.

Example: Fixture which do not communicate with computer are indicated by yellow background.

| Device            | DMX address | DMX preset           | RDM UID           | IP address    | RAINS (max wet) | Device status |
|-------------------|-------------|----------------------|-------------------|---------------|-----------------|---------------|
| iPainte           | 221         | Mode 1 (44 channels) | 52:53:01:35:00:25 | 2.247.196.37  |                 | disconnected  |
| iSpider           | 1           | Mode 1 (49 channels) | 52:53:01:1c:00:0e | 2.246.236.14  |                 | active        |
| iSpider           | 1           | Mode 1 (49 channels) | 52:53:01:1c:03:d8 | 2.246.239.216 |                 | active        |
| iForte - iForte 3 | 1           | Mode 1 (54 channels) | 52:53:01:2c:00:1a | 2.247.136.26  |                 | active        |
| iForte - iForte 1 | 1           | Mode 1 (54 channels) | 52:53:01:2c:00:13 | 2.247.136.19  |                 | active        |

If the option Move devices with warning to top is checked, fixtures with some error will be displayed on the top of fixture list.

The option Columns selection allows you to check desired items which will be displayed in columns. Max. 6 items can be selected. After checking desired items, click on the blue button Apply selection to activate selection. Icons allows you to order values in the column in descending or ascending order.

Note: The values of the fixture in the first blue row ("server fixture") will not be included into ordering.

Example.

The screenshot shows the ROBE Discovery interface. At the top, there are navigation tabs: Status, Personality, Logs, RAINS logs, Discovery, Settings. Below the tabs, there are several settings sections:

- Discovery**: Includes a checkbox for "Move devices with warning to top" (checked) and a "Discover (4)" button.
- Columns selection (max. 7 items)**: A list of checkboxes for various data points: DMX address, DMX preset, RDM UID, IP address, Head temperature [°C], Relative humidity [%], RAINS (max wet), Last pressure test, and Device status. The "Device status" checkbox is checked.
- Apply selection**: A blue button to confirm the column selection.

Below the settings is a table of fixtures:

| Device            | DMX address | DMX preset            | RDM UID           | IP address   | RAINS (max wet) | Device status |
|-------------------|-------------|-----------------------|-------------------|--------------|-----------------|---------------|
| iBolt             | 353         | Mode 1 (36 channels)  | 52:53:01:38:00:00 | 2.248.16.0   |                 | active        |
| iForte - iForte 3 | 1           | Mode 1 (54 channels)  | 52:53:01:2c:00:1a | 2.247.136.26 |                 | active        |
| iBeam 350         | 1           | Mode 1 (22 channels)  | 52:53:01:33:00:43 | 2.247.220.67 |                 | active        |
| iTetra2           | 1           | Mode 6 (128 channels) | 52:53:01:34:00:2a | 2.247.216.42 |                 | active        |

The **screen Settings** allows you to change password to REAP.

The screenshot shows the ROBE Settings interface. A "Site settings" dialog box is open over the Discovery table. The dialog box has the following sections:

- Password settings**: Includes fields for "Old password", "New password", and "New password check".
- Save**: A blue button at the bottom right of the dialog box.

The background Discovery table is partially visible, showing the same fixture list as in the previous screenshot.

The icon serves for identification of the fixture in a group of fixtures. After clicking on the icon, the fixture's head will start to move.



Gobos order:

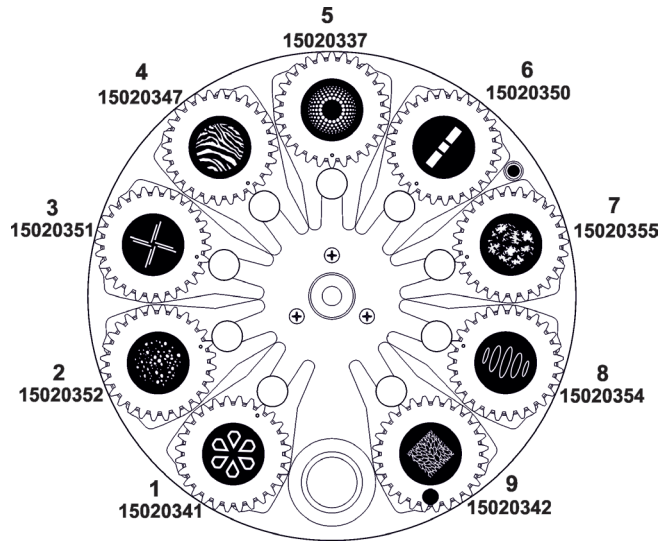

**Prism wheel 1**

- 1- Rotating 6-facet linear prism with continuous rotation in both directions
- 2- Rotating 6-facet linear multicoloured prism with continuous rotation in both directions
- 3- Rotating 8-facet 12° circular prism with continuous rotation in both directions

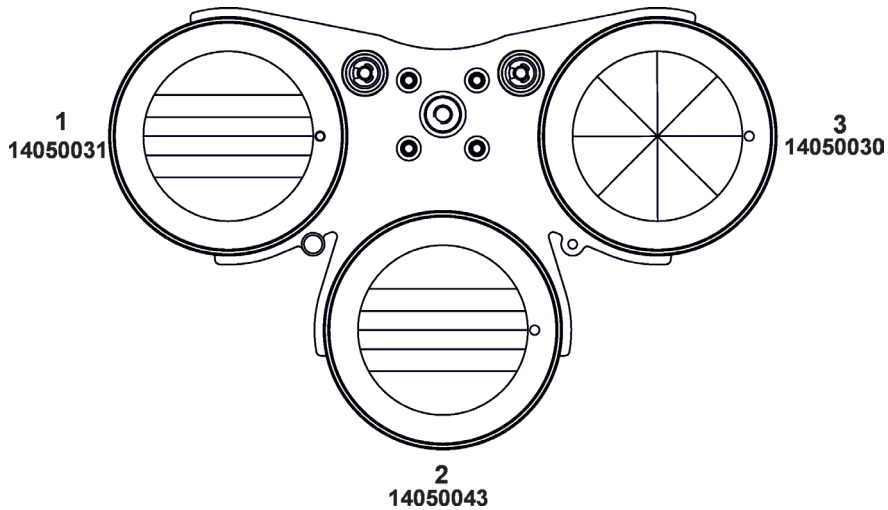

**Prism wheel 2**

- 1- Rotating 6-facet linear prism with continuous rotation in both directions
- 2- Rotating 32-facet circular prism with continuous rotation in both directions
- 3- Rotating 8-facet 18° circular prism with continuous rotation in both directions

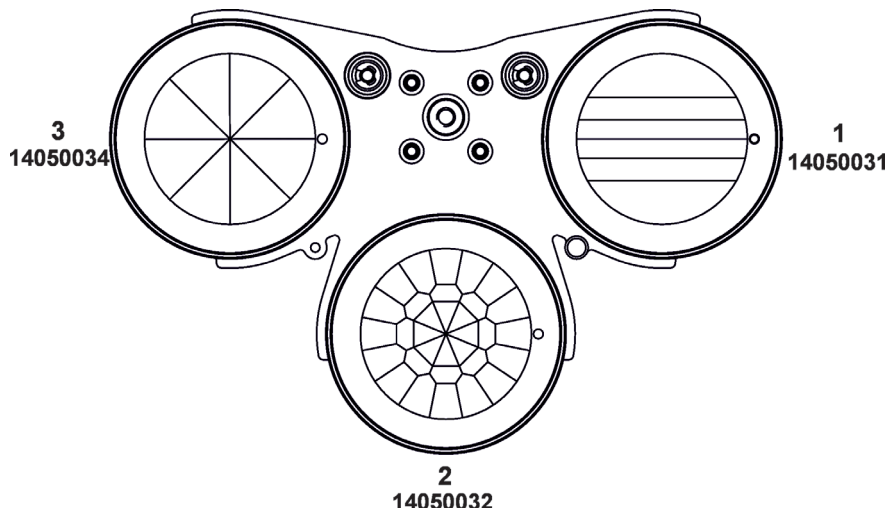

**Zoom**

Motorized zoom 0.4° - 8.5°

**Focus**

Motorized focus.

**Strobe**

Strobe effect with variable speed (0.3 - 20Hz)

**Dimmer**

Smooth dimmer from 0 - 100 %

**Pan/Tilt**

Pan movement range 540°  
Tilt movement range 265°  
16 bit movement resolution  
Pan continual rotation  
Automatic Pan/Tilt position correction  
Pan/Tilt electronic motion stabilizer  
Remotely controllable speed of pan/tilt

**Control**

Graphic screen for fixture setting and addressing  
Gravitation sensor for auto screen positioning  
Readout fixture usage, receiving DMX values, temperatures, etc  
Built-in analyzer for easy fault finding, error messages  
Supported protocols: USITT DMX 512, RDM, ArtNet, MA Net, MA Net2, sACN  
1 DMX mode (37 control channels)  
REAP™ - Robe Ethernet Access Portal

**Wireless DMX/RDM module type RW 001**

Supported protocols: full RDM support, CRMX , W-DMX™ G2, G3,G4 and G4S  
Operational frequency range: 2402-2480 MHz  
Output power: 100 mW  
Receiver sensitivity (0.1% BER): -93 dBm  
Crystal Clock Frequency : 16.0 MHz

**Max. number of fixtures in Ethernet IN/Out line**

8

**Connection**

DMX data in/out: 2 x IP65 Locking 5-pin XLR connector Seetronic  
Ethernet: 2 x IP65 RJ45 connector Seetronic  
Power: IP65 power connector Seetronic

**Rigging**

Mounting points: 2 pairs of 1/4-turn locks  
Mounting horizontally or vertically via two Omega holders

**Temperatures**

Minimum/Maximum ambient operating temperature : -50°C/+50°C  
Maximum housing temperature : 70° C



## Thermal hazard distances

### Sky mode

Min. distance from flammable surface: 0.5 m  
Min. distance from illuminated surface: 45 m

### Stage mode

Min. distance from flammable surface: 0.5 m  
Min. distance from illuminated surface depends on setting on the channel Safety control (channel 8, DMX range of 45-58):

| <u>Stage mode safe distance</u>    | <u>Min. distance from illuminated surface</u> |
|------------------------------------|---|
| Stage mode safe distance from 10 m | min. 7 m                                      |
| Stage mode safe distance from 20 m | min. 16 m                                     |
| Stage mode safe distance from 30 m | min. 22 m                                     |
| Stage mode safe distance from 40 m | min. 31 m                                     |
| Stage mode safe distance from 50 m | min. 35 m                                     |
| Stage mode safe distance from 60 m | min. 38 m                                     |
| Stage mode safe distance from 70 m | min. 41 m                                     |

## Retinal thermal hazard distance

### Sky mode

min. 80 m

### Stage mode

Retinal thermal hazard distance depends on setting on the channel Safety control (channel 8, DMX range of 45-58):

| <u>Stage mode safe distance</u>    | <u>Retinal thermal hazard</u> |
|------------------------------------|-------------------------------|
| Stage mode safe distance from 10 m | min. 10 m                     |
| Stage mode safe distance from 20 m | min. 20 m                     |
| Stage mode safe distance from 30 m | min. 30 m                     |
| Stage mode safe distance from 40 m | min. 40 m                     |
| Stage mode safe distance from 50 m | min. 50 m                     |
| Stage mode safe distance from 60 m | min. 60 m                     |
| Stage mode safe distance from 70 m | min. 70 m                     |

## Total heat dissipation

max. 1790 BTU/h (calculated)

## Ingress protection rating

IP65

## Weight

54.4 kg (120 lbs)

## Desiccants

Total weight of all silica gel fillings in the fixture is 350 g

## Accessories

1 x Omega adaptor CL-regular 2 pcs in box (P/N 10980033)  
1 x Power cable including powerCON TRUE1 In connector  
1 x Lens cover for iBOLT (P/N 10981075)

## Optional accessories

(P/N 10980033) Omega Adaptor CL-regular 2 pcs  
(P/N 17030386) Doughty Trigger Clamp  
(P/N 99011964) Safety wire 100 kg

## Dimensions (mm)

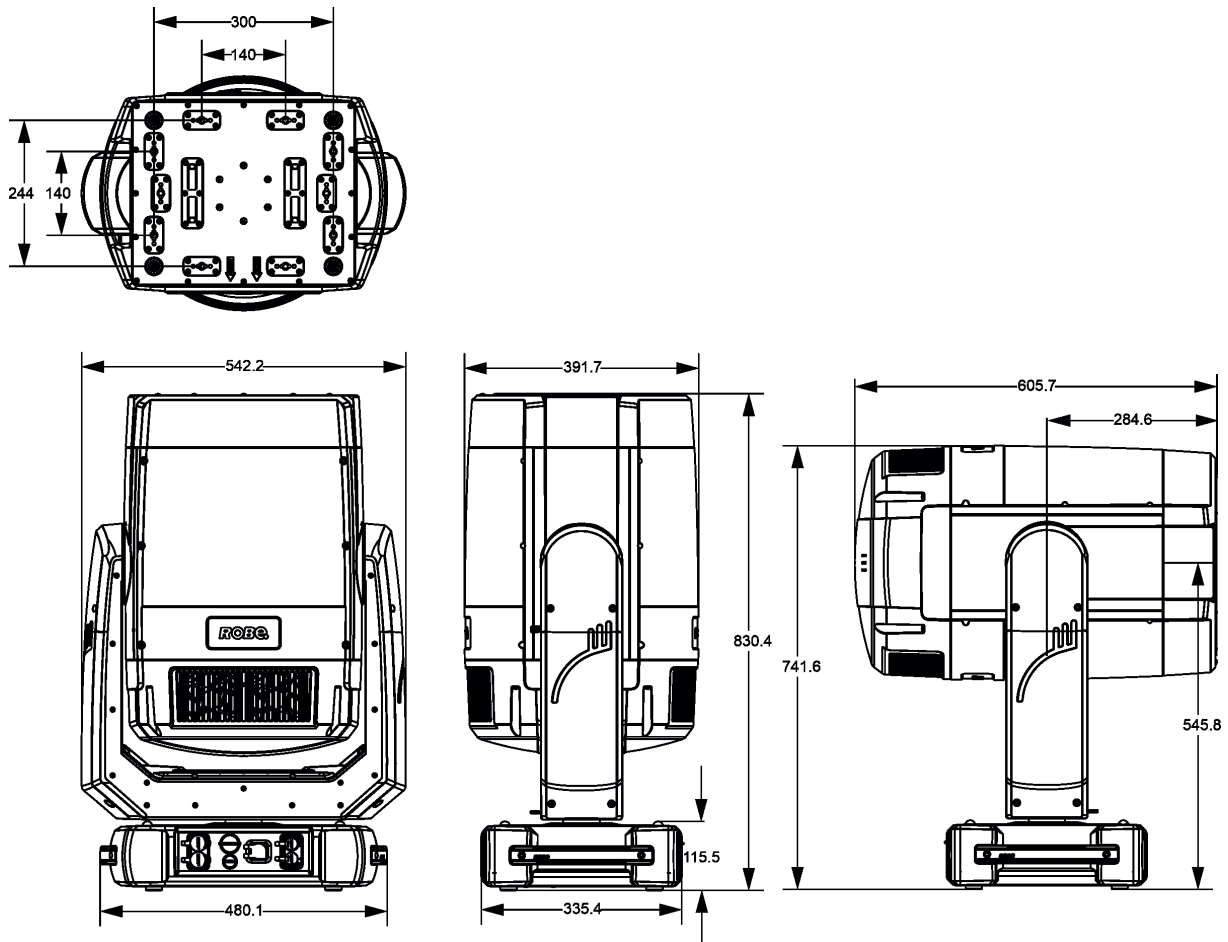

## 19. ChangeLog

This section summarizes changes in the user manual.

| Version of the manual | Date of issue | Description of changes  |
|-----------------------|---------------|---|
| 1.1                   | 13/12/2023    | Dmx chart ver. 1.4 - Leds ring removed                              |
| 1.2                   | 08/02/2024    | DMX chart ver. 1.8  |
| 1.3                   | 28/02/2024    | Sky mode added to display menu                                      |
| 1.4                   | 04/03/2024    | Safety instructions changed   |
| 1.5                   | 27/03/2024    | Stage mode added  |
| 1.6                   | 05/04/2024    | Safety instructions changed   |
| 1.7                   | 15/04/2024    | Safety instructions added   |
| 1.8                   | 20/04/2024    | Safety instructions changed   |
| 1.9                   | 29/04/2024    | Loader Case manipulation added                                      |
| 2.0                   | 17/05/2024    | DMX chart ver. 2.2  |
| 2.1                   | 22/05/2024    | Sky a Stage mode behaviour changed                                  |
| 2.2                   | 27/06/2024    | Safety instructions changed   |
| 2.3                   | 09/08/2024    | Retinal thermal hazard distance in Sky mode changed                 |
| 2.4                   | 27/08/2024    | Pressure test temperature change to 30°C.                           |
| 2.5                   | 05/12/2024    | Min.ambient temperature changed                                     |
| 2.6                   | 16/01/2025    | Zoom/focus restricted combinations                                  |
| 2.7                   | 25/02/2025    | Stage mode distance and pan/tilt for Sky mode zone definition added |
| 2.8                   | 05/03/2025    | Safety warning in the chapter "4.7 Stage mode and Sky mode" changed |

March 5, 2025

Copyright © 2023-2025 Robe Lighting - All rights reserved

All Specifications subject to change without notice

Made in CZECH REPUBLIC by ROBE LIGHTING s.r.o. Palackeho 416/20 CZ 75701 Valasske Mezirici



DMX protocol

| <b>Robin iBOLT™ - DMX protocol</b>  |                  |  |                        |
|---|------------------|--|------------------------|
| <b>The iBolt cannot be programmed in the Stage mode and then used in the Sky mode and vice versa.</b> |                  |  |                        |
| Version: 2.5 Mode 1-Standard 16-bit   |                  |  |                        |
| <b>Mode/Total channels</b>  |                  | <b>Function</b>  | <b>Type of control</b> |
| <b>1/37</b>   | <b>DMX Value</b> |  |                        |
| <b>1</b>  |                  | <b>Pan</b>   |                        |
|   | 0 - 255          | Pan movement by 540°/360° (128=default)  | proportional           |
| <b>2</b>  |                  | <b>Pan Fine</b>  |                        |
|   | 0 - 255          | Fine control of pan movement (0=default)   | proportional           |
| <b>3</b>  |                  | <b>Tilt</b>  |                        |
|   | 0 - 255          | Tilt movement by 265° (128=default)  | proportional           |
| <b>4</b>  |                  | <b>Tilt fine</b>   |                        |
|   | 0 - 255          | Fine control of tilt movement (0=default)  | proportional           |
| <b>5</b>  |                  | <b>Pan control</b>   |                        |
|   | 0                | Pan range 540°, shortcut Off (0=default)   | step                   |
|   | 1                | Pan range 360°, shortcut On  | step                   |
|   | 2-127            | No function (Pan range 540°, shortcut Off)   |                        |
|   | 128-189          | Continuous rotation fast -> slow , Forwards  | proportional           |
|   | 190-193          | Stop rotation  | step                   |
|   | 194-255          | Continuous rotation slow -> fast , Backwards   | proportional           |
| <b>6</b>  |                  | <b>Pan/Tilt speed , Pan/Tilt time</b>  |                        |
|   | 0                | Standard mode (0=default)  | step                   |
|   | 1                | Max. Speed Mode  | step                   |
|   |                  | <b>Pan/Tilt speed mode</b>   |                        |
|   | 2 - 255          | Speed from max. to min.  | proportional           |
|   |                  | <b>Pan/Tilt time mode</b>  |                        |
|   | 2 - 255          | Time from 0.2 s to 25.5 sec.   | proportional           |
| <b>7</b>  |                  | <b>Power/Special functions</b>   |                        |
|   | 0 - 1            | No function (0=default)<br><i>To activate following functions (2-129DMX), stop in DMX value for at least 3 s and shutter must be closed at least 3 sec. („Shutter,Strobe“ channel 35 must be at range: 0-31 DMX). Corresponding menu items are temporarily overridden.</i> |                        |
|   | 2-3              | DMX input: Wired DMX *   | step                   |
|   | 4-5              | DMX input: Wireless DMX *  | step                   |
|   |                  | <i>* function is active only 10 seconds after switching the fixture on</i>   |                        |
|   | 6-21             | Reserved   |                        |
|   | 22-23            | Standby mode: On (fixture effects are deactivated, light output is closed)   | step                   |
|   | 24-25            | Standby mode: Off  | step                   |
|   | 26-27            | Pressure test: On ( fixture does not respond to DMX during the test except values 28-29 (Pressure test Off))   | step                   |
|   | 28-29            | Pressure test: Off   | step                   |
|   | 30-41            | Reserved   |                        |
|   | 42-43            | Graphic display: On  | step                   |
|   | 44-45            | Graphic display: Off   | step                   |
|   | 46-47            | Pan/Tilt mode: Speed   | step                   |
|   | 48-49            | Pan/Tilt mode: Time  | step                   |
|   | 50-51            | Quiet mode: Fans On at blackout  | step                   |
|   | 52-53            | Quiet mode: Fans Off at blackout   | step                   |

DMX protocol

| Mode/Total channels |           | Function   | Type of control |
|---------------------|-----------|--|-----------------|
| 1/37                | DMX Value |  |                 |
|                     | 54-121    | Reserved   |                 |
|                     | 122-123   | Dimmer curve: Linear   | step            |
|                     | 124-125   | Dimmer curve: Square law   | step            |
|                     | 126-127   | Parking position: On   | step            |
|                     | 128-129   | Parking position: Off  | step            |
|                     |           | <u>To activate following functions (130-255 DMX), stop in DMX value for at least 3 seconds.</u>  |                 |
|                     | 130-131   | Total fixture reset (including pan/tilt)   | step            |
|                     | 132-133   | Pan/Tilt reset   | step            |
|                     | 134-135   | Colour wheels reset  | step            |
|                     | 136-137   | Gobo wheels reset  | step            |
|                     | 138-139   | Zoom/Focus/prisms/frost reset  | step            |
|                     | 140-217   | Reserved   |                 |
|                     |           | <i>The following three commands define transition from gobo rotation to gobo indexing:</i>   |                 |
|                     | 218-219   | Gobo indexing: Maximum speed and shortcut  | step            |
|                     | 220-221   | Gobo indexing: Follow speed and direction  | step            |
|                     | 222-223   | Gobo indexing: Maximum speed and follow direction  | step            |
|                     | 224-225   | Reserved   |                 |
|                     | 226       | Dimmer activation*   | step            |
|                     |           | <i>*To activate DIMMER of the fixture, select the option on this channel and set the channel <b>Safety control</b> at 39-40 DMX. Stop at DMX values for at least 3 seconds at the same time on the two channels. Activation is needed only for new fixture or if DIMMER was deactivated by DMX command on the channel 8.</i> |                 |
|                     | 227-233   | Reserved   |                 |
|                     | 234-235   | Fans mode: Auto  | step            |
|                     | 236-237   | Fans mode: High  | step            |
|                     | 238-239   | Reserved   |                 |
|                     | 240 - 255 | Fans mode: Quiet - fan noise control from min. to max.   | proportional    |
| <b>8</b>            |           | <b>Safety control</b>  |                 |
|                     | 0-2       | Lidar is Off<br><i>If Lidar is active, the light output from the fixture is automatically closed if some obstacle (person, object) appears in the light beam in selected distance from the fixture. Stop at DMX values for at least 3 seconds to activate desired Lidar distance. Default value in the fixture is 5m.</i>    | step            |
|                     | 3-4       | Lidar is active to 2 m   | step            |
|                     | 5-6       | Lidar is active to 5 m (5=default)   | step            |
|                     | 7-8       | Lidar is active to 10 m  | step            |
|                     | 9-10      | Lidar is active to 15 m  | step            |
|                     | 11-12     | Lidar is active to 20 m  | step            |
|                     | 13-14     | Lidar is active to 25 m  | step            |
|                     | 15-16     | Lidar is active to 30 m  | step            |
|                     | 17-18     | Lidar is active to 35 m  | step            |
|                     | 19-20     | Lidar is active to 40 m  | step            |
|                     | 21-22     | Lidar is active to 45 m  | step            |
|                     | 23-24     | Lidar is active to 50 m  | step            |
|                     | 25-26     | Lidar is active to 55 m  | step            |

DMX protocol

| Mode/Total channels |           | Function   | Type of control |
|---------------------|-----------|--|-----------------|
| 1/37                | DMX Value |  |                 |
|                     | 27-28     | Lidar is active to 60 m  | step            |
|                     | 29-30     | Lidar is active to 65 m  | step            |
|                     | 31-32     | Lidar is active to 70 m  | step            |
|                     | 33-34     | Lidar is active to 75 m  | step            |
|                     | 35-36     | Lidar is active to 80 m  | step            |
|                     | 37-38     | Dimmer deactivation  | step            |
|                     | 39-40     | Dimmer activation*   | step            |
|                     |           | <i>*To activate DIMMER of the fixture, select the option on this channel and set the channel <b>Power/Special functions</b> at 226 DMX. Stop at DMX values for at least 3 seconds at the same time on the two channels. Activation is needed only for new fixture or if DIMMER was deactivated by DMX command (37-38) on this channel.</i> |                 |
|                     | 41-42     | Sky mode On  | step            |
|                     | 43-44     | Reserved   |                 |
|                     |           | <i>To set Stage Mode safe distance, stop at DMX value for at least 3 seconds. Default value set in the fixture is 40 m.</i>  |                 |
|                     | 45-46     | Stage mode safe distance from 10 m   | step            |
|                     | 47-48     | Stage mode safe distance from 20 m   | step            |
|                     | 49-50     | Stage mode safe distance from 30 m   | step            |
|                     | 51-52     | Stage mode safe distance from 40 m   | step            |
|                     | 53-54     | Stage mode safe distance from 50 m   | step            |
|                     | 55-56     | Stage mode safe distance from 60 m   | step            |
|                     | 57-58     | Stage mode safe distance from 70 m   | step            |
|                     |           | <i>To set functions stated below, stop at DMX value for at least 3 seconds.</i>  |                 |
|                     | 59-60     | Tilt min. (full intensity zone definition)**   | step            |
|                     | 61-62     | Tilt max. (full intensity zone definition)**   | step            |
|                     | 63-64     | Pan min. (full intensity zone definition)**  | step            |
|                     | 65-66     | Pan max. (full intensity zone definition)**  | step            |
|                     | 67-68     | Limited intensity zone Cut-off (fixture default)***  | step            |
|                     | 69-70     | Limited intensity zone Stage mode from 10 m  | step            |
|                     | 71-72     | Limited intensity zone Stage mode from 20 m  | step            |
|                     | 73-74     | Limited intensity zone Stage mode from 30 m  | step            |
|                     | 75-76     | Limited intensity zone Stage mode from 40 m  | step            |
|                     | 77-78     | Limited intensity zone Stage mode from 50 m  | step            |
|                     | 79-80     | Limited intensity zone Stage mode from 60 m  | step            |
|                     | 81-82     | Limited intensity zone Stage mode from 70 m  | step            |
|                     | 83-84     | Reset to default (P/T intensity zone)**  | step            |
|                     |           | <i>** 4 flashes per second for a period of three seconds indicate saving of Pan or Tilt value or Reset to default (P/T intensity zone).</i>  |                 |
|                     |           | <i>*** The option Cut-off is set as Default in the fixture after setting items Tilt min./Tilt max and Pan min./Pan max.</i>  |                 |
|                     | 85-255    | Raw DMX  |                 |
| <b>9</b>            |           | <b>Colour wheel</b>  |                 |
|                     |           | <b>Continual positioning</b>   |                 |
|                     | 0         | Open/white (0=default)   | proportional    |
|                     | 9         | Deep Red   | proportional    |
|                     | 18        | Deep Blue  | proportional    |

DMX protocol

| <b>Mode/Total channels</b> |                  | <b>Function</b>   | <b>Type of control</b> |
|----------------------------|------------------|---|------------------------|
| <b>1/37</b>                | <b>DMX Value</b> |   |                        |
|                            | 27               | Yellow  | proportional           |
|                            | 37               | Light green   | proportional           |
|                            | 46               | Magenta   | proportional           |
|                            | 55               | Lavender  | proportional           |
|                            | 64               | Pink  | proportional           |
|                            | 73               | Dark green  | proportional           |
|                            | 82               | CTO 2700K   | proportional           |
|                            | 91               | Blue  | proportional           |
|                            | 101              | Orange  | proportional           |
|                            | 110              | CTO 3200K   | proportional           |
|                            | 119              | UV (Congo blue)   | proportional           |
|                            | 128-129          | White   | step                   |
|                            |                  | <b>Positioning</b>  |                        |
|                            | 130-134          | Deep Red  | step                   |
|                            | 135-138          | Deep Blue   | step                   |
|                            | 139-143          | Yellow  | step                   |
|                            | 144-147          | Light green   | step                   |
|                            | 148-152          | Magenta   | step                   |
|                            | 153-157          | Lavender  | step                   |
|                            | 158-161          | Pink  | step                   |
|                            | 162-166          | Dark green  | step                   |
|                            | 167-171          | CTO 2700K   | step                   |
|                            | 172-176          | Blue  | step                   |
|                            | 177-180          | Orange  | step                   |
|                            | 181-185          | CTO 3200K   | step                   |
|                            | 186-189          | UV (Congo blue)   | step                   |
|                            | 190-215          | Forwards rainbow effect from fast to slow                 | proportional           |
|                            | 216-217          | No rotation   | step                   |
|                            | 218-243          | Backwards rainbow effect from slow to fast                | proportional           |
|                            | 244-249          | Reserved  |                        |
|                            | 250-255          | Auto random colour selection from fast to slow            | proportional           |
| <b>10</b>                  |                  | <b>Colour wheel - fine positioning</b>                    |                        |
|                            | 0 - 255          | Fine positioning (0=default)                              | proportional           |
| <b>11</b>                  |                  | <b>Cyan</b>   |                        |
|                            | 0 - 255          | Cyan from min. saturation --> full cyan (0=default)       | proportional           |
| <b>12</b>                  |                  | <b>Magenta</b>  |                        |
|                            | 0 - 255          | Magenta from min. saturation --> full magenta (0=default) | proportional           |
| <b>13</b>                  |                  | <b>Yellow</b>   |                        |
|                            | 0 - 255          | Yellow from min. saturation --> full yellow (0=default)   | proportional           |
| <b>14</b>                  |                  | <b>Virtual colour wheel</b>                               |                        |
|                            |                  | <i>The following channels are disabled: 9-13</i>          |                        |
|                            | 0                | No function (0=default)                                   | step                   |
|                            | 1-2              | Filter 4 (Medium Bastard Amber)                           | step                   |
|                            | 3-4              | Filter 10 (Medium Yellow)                                 | step                   |
|                            | 5-6              | Filter 19 (Fire)  | step                   |
|                            | 7-8              | Filter 26 (Bright Red)                                    | step                   |
|                            | 9-10             | Filter 58 (Lavender)                                      | step                   |
|                            | 11-12            | Filter 68 (Sky Blue)                                      | step                   |

DMX protocol

| <b>Mode/Total channels</b> |                  | <b>Function</b>                | <b>Type of control</b> |
|----------------------------|------------------|--------------------------------|------------------------|
| <b>1/37</b>                | <b>DMX Value</b> |                                |                        |
|                            | 13-14            | Filter 71 (Tokyo Blue)         | step                   |
|                            | 15-16            | Filter 79 (Just Blue)          | step                   |
|                            | 17-18            | Filter 88 (Lime Green)         | step                   |
|                            | 19-20            | Filter 90 (Dark Yellow Green)  | step                   |
|                            | 21-22            | Filter 100 (Spring Yellow)     | step                   |
|                            | 23-24            | Filter 101 (Yellow)            | step                   |
|                            | 25-26            | Filter 102 (Light Amber)       | step                   |
|                            | 27-28            | Filter 103 (Straw)             | step                   |
|                            | 29-30            | Filter 104 (Deep Amber)        | step                   |
|                            | 31-32            | Filter 105 (Orange)            | step                   |
|                            | 33-34            | Filter 106 (Primary Red)       | step                   |
|                            | 35-36            | Filter 111 (Dark Pink)         | step                   |
|                            | 37-38            | Filter 115 (Peacock Blue)      | step                   |
|                            | 39-40            | Filter 116 (Medium Blue-Green) | step                   |
|                            | 41-42            | Filter 117 (Steel Blue)        | step                   |
|                            | 43-44            | Filter 118 (Light Blue)        | step                   |
|                            | 45-46            | Filter 119 (Dark Blue)         | step                   |
|                            | 47-48            | Filter 120 (Deep Blue)         | step                   |
|                            | 49-50            | Filter 121 (Filter Green)      | step                   |
|                            | 51-52            | Filter 128 (Bright Pink)       | step                   |
|                            | 53-54            | Filter 131 (Marine Blue)       | step                   |
|                            | 55-56            | Filter 132 (Medium Blue)       | step                   |
|                            | 57-58            | Filter 134 (Golden Amber)      | step                   |
|                            | 59-60            | Filter 135 (Deep Golden Amber) | step                   |
|                            | 61-62            | Filter 136 (Pale Lavender)     | step                   |
|                            | 63-64            | Filter 137 (Special Lavender)  | step                   |
|                            | 65-66            | Filter 138 (Pale Green)        | step                   |
|                            | 67-68            | Filter 139 (Primary Green)     | step                   |
|                            | 69-70            | Filter 141 (Bright Blue)       | step                   |
|                            | 71-72            | Filter 147 (Apricot)           | step                   |
|                            | 73-74            | Filter 148 (Bright Rose)       | step                   |
|                            | 75-76            | Filter 152 (Pale Gold)         | step                   |
|                            | 77-78            | Filter 154 (Pale Rose)         | step                   |
|                            | 79-80            | Filter 157 (Pink)              | step                   |
|                            | 81-82            | Filter 158 (Deep Orange)       | step                   |
|                            | 83-84            | Filter 162 (Bastard Amber)     | step                   |
|                            | 85-86            | Filter 164 (Flame Red)         | step                   |
|                            | 87-88            | Filter 165 (Daylight Blue)     | step                   |
|                            | 89-90            | Filter 169 (Lilac Tint)        | step                   |
|                            | 91-92            | Filter 170 (Deep Lavender)     | step                   |
|                            | 93-94            | Filter 172 (Lagoon Blue)       | step                   |
|                            | 95-96            | Filter 179 (Chrome Orange)     | step                   |
|                            | 97-98            | Filter 180 (Dark Lavender)     | step                   |
|                            | 99-100           | Filter 181 (Congo Blue)        | step                   |
|                            | 101-102          | Filter 197 (Alice Blue)        | step                   |
|                            | 103-104          | Filter 201 (Full C.T. Blue)    | step                   |
|                            | 105-106          | Filter 202 (Half C.T. Blue)    | step                   |
|                            | 107-108          | Filter 203 (Quarter C.T. Blue) | step                   |

DMX protocol

| <b>Mode/Total channels</b> |                  | <b>Function</b>   | <b>Type of control</b> |
|----------------------------|------------------|---|------------------------|
| <b>1/37</b>                | <b>DMX Value</b> |   |                        |
|                            | 109-110          | Filter 204 (Full C.T. Orange)                             | step                   |
|                            | 111-112          | Filter 205 (Half C.T. Orange)                             | step                   |
|                            | 113-114          | Filter 206 (Quarter C.T. Orange)                          | step                   |
|                            | 115-116          | Filter 247 (Filter Minus Green)                           | step                   |
|                            | 117-118          | Filter 248 (Half Minus Green)                             | step                   |
|                            | 119-120          | Filter 281 (Three Quarter C.T. Blue)                      | step                   |
|                            | 121-122          | Filter 285 (Three Quarter C.T. Orange)                    | step                   |
|                            | 123-124          | Filter 352 (Glacier Blue)                                 | step                   |
|                            | 125-126          | Filter 353 (Lighter Blue)                                 | step                   |
|                            | 127-128          | Filter 715 (Cabana Blue)                                  | step                   |
|                            | 129-130          | Filter 778 (Millennium Gold)                              | step                   |
|                            | 131-132          | Filter 793 (Vanity Fair)                                  | step                   |
|                            | 133-255          | Reserved  |                        |
| <b>15</b>                  |                  | <b>CMY and Colour wheel time</b>                          |                        |
|                            | 0                | Function is off (0=default)                               | step                   |
|                            | 1 - 255          | Time of CMY and Colour wheel movement (0.1sec-->25.5sec.) | proportional           |
| <b>16</b>                  |                  | <b>Zoom/Focus/Prism time</b>                              |                        |
|                            | 0                | Function is off (0=default)                               | step                   |
|                            | 1 - 255          | Time of zoom/focus movement (0.1 sec-->25.5 sec.)         | proportional           |
|                            | 1-50             | Time of prism movement (0.1 sec-->5 sec.)                 | proportional           |
| <b>17</b>                  |                  | <b>Static gobo wheel</b>                                  |                        |
|                            | 0-3              | Open/hole   | step                   |
|                            |                  | <b><u>Positioning</u></b>                                 |                        |
|                            | 4-9              | Gobo 1  | step                   |
|                            | 10-15            | Gobo 2  | step                   |
|                            | 16-21            | Gobo 3  | step                   |
|                            | 22-27            | Gobo 4  | step                   |
|                            | 28-33            | Gobo 5  | step                   |
|                            | 34-39            | Gobo 6  | step                   |
|                            | 40-45            | Gobo 7  | step                   |
|                            | 46-51            | Gobo 8  | step                   |
|                            | 52-57            | Gobo 9  | step                   |
|                            | 58-63            | Gobo 10   | step                   |
|                            | 64-69            | Beam reducer 1  | step                   |
|                            | 70-75            | Beam reducer 2  | step                   |
|                            | 76-81            | Beam reducer 3  | step                   |
|                            | 82-87            | Beam reducer 4  | step                   |
|                            |                  | <b><u>Shaking gobos from slow to fast</u></b>             |                        |
|                            | 88-95            | Gobo 1  | proportional           |
|                            | 96-103           | Gobo 2  | proportional           |
|                            | 104-111          | Gobo 3  | proportional           |
|                            | 112-119          | Gobo 4  | proportional           |
|                            | 120-127          | Gobo 5  | proportional           |
|                            | 128-135          | Gobo 6  | proportional           |
|                            | 136-143          | Gobo 7  | proportional           |
|                            | 144-151          | Gobo 8  | proportional           |
|                            | 152-159          | Gobo 9  | proportional           |
|                            | 160-167          | Gobo 10   | proportional           |



DMX protocol

| <b>Mode/Total channels</b> |                  | <b>Function</b>   | <b>Type of control</b> |
|----------------------------|------------------|---|------------------------|
| <b>1/37</b>                | <b>DMX Value</b> |   |                        |
|                            | 168-175          | Beam reducer 1  | proportional           |
|                            | 176-183          | Beam reducer 2  | proportional           |
|                            | 184-191          | Beam reducer 3  | proportional           |
|                            | 192-199          | Beam reducer 4  | proportional           |
|                            | 200-201          | Open/hole   | step                   |
|                            | 202 - 222        | Forwards gobo wheel rotation from fast to slow                        | proportional           |
|                            | 223 - 243        | Backwards gobo wheel rotation from slow to fast                       | proportional           |
|                            | 244 - 249        | Reserved  |                        |
|                            | 250 - 255        | <i>Auto random gobo selection from fast to slow</i>                   | proportional           |
| <b>18</b>                  |                  | <b>Rotating gobo wheel</b>  |                        |
|                            |                  | <i>When rotating gobos are used, the channel Frost is not active.</i> |                        |
|                            |                  | <i>Index - set indexing on channel 20</i>                             |                        |
|                            | 0                | Open/Hole (default)   | step                   |
|                            | 1-4              | Hole (flat field)   | step                   |
|                            | 5-7              | Gobo 1  | step                   |
|                            | 8-10             | Gobo 2  | step                   |
|                            | 11-13            | Gobo 3  | step                   |
|                            | 14-16            | Gobo 4  | step                   |
|                            | 17-19            | Gobo 5  | step                   |
|                            | 20-22            | Gobo 6  | step                   |
|                            | 23-25            | Gobo 7  | step                   |
|                            | 26-28            | Gobo 8  | step                   |
|                            | 29-31            | Gobo 9  | step                   |
|                            |                  | <i>Rotation - set rotation on channel 20</i>                          |                        |
|                            | 32-34            | Gobo 1  | step                   |
|                            | 35-37            | Gobo 2  | step                   |
|                            | 38-40            | Gobo 3  | step                   |
|                            | 41-43            | Gobo 4  | step                   |
|                            | 44-46            | Gobo 5  | step                   |
|                            | 47-49            | Gobo 6  | step                   |
|                            | 50-52            | Gobo 7  | step                   |
|                            | 53-55            | Gobo 8  | step                   |
|                            | 56-59            | Gobo 9  | step                   |
|                            |                  | <b>Continual positioning</b>  |                        |
|                            |                  | <i>Index - set indexing on channel 20</i>                             |                        |
|                            | 60               | Open/hole   | proportional           |
|                            | 67               | Gobo 1  | proportional           |
|                            | 74               | Gobo 2  | proportional           |
|                            | 81               | Gobo 3  | proportional           |
|                            | 88               | Gobo 4  | proportional           |
|                            | 95               | Gobo 5  | proportional           |
|                            | 102              | Gobo 6  | proportional           |
|                            | 109              | Gobo 7  | proportional           |
|                            | 116              | Gobo 8  | proportional           |
|                            | 123              | Gobo 9  | proportional           |
|                            | 130              | Open/hole   | proportional           |
|                            |                  | <b>Continual positioning</b>  |                        |
|                            |                  | <i>Rotation - set rotation on channel 20</i>                          |                        |

DMX protocol

| <b>Mode/Total channels</b> |                  | <b>Function</b>   | <b>Type of control</b> |
|----------------------------|------------------|---|------------------------|
| <b>1/37</b>                | <b>DMX Value</b> |   |                        |
|                            | 131              | Open/hole   | proportional           |
|                            | 138              | Gobo 1  | proportional           |
|                            | 145              | Gobo 2  | proportional           |
|                            | 152              | Gobo 3  | proportional           |
|                            | 159              | Gobo 4  | proportional           |
|                            | 166              | Gobo 5  | proportional           |
|                            | 173              | Gobo 6  | proportional           |
|                            | 180              | Gobo 7  | proportional           |
|                            | 187              | Gobo 8  | proportional           |
|                            | 194              | Gobo 9  | proportional           |
|                            | 201              | Open/hole   | proportional           |
|                            | 202 - 222        | Forwards gobo wheel rotation from fast to slow                | proportional           |
|                            | 223 - 243        | Backwards gobo wheel rotation from slow to fast               | proportional           |
|                            | 244 - 249        | Reserved  |                        |
|                            | 250 - 255        | Auto random gobo selection from fast to slow                  | proportional           |
| <b>19</b>                  |                  | <b>Rotating gobo wheel - fine positioning</b>                 |                        |
|                            | 0 - 255          | Fine positioning (0=default)                                  | proportional           |
| <b>20</b>                  |                  | <b>Rot. Gobo indexing/rotation</b>                            |                        |
|                            |                  | <i>Gobo indexing - set position on channel 18</i>             |                        |
|                            | 0 - 255          | Gobo indexing (128=default)                                   | proportional           |
|                            |                  | <i>Gobo rotation - set position on channel 18</i>             |                        |
|                            | 0                | No rotation   | step                   |
|                            | 1 - 127          | Forwards gobo rotation from fast to slow                      | proportional           |
|                            | 128              | No rotation (128=default)                                     | step                   |
|                            | 129 - 255        | Backwards gobo rotation from slow to fast                     | proportional           |
| <b>21</b>                  |                  | <b>Rot. Gobo indexing/rotation - fine</b>                     |                        |
|                            | 0-255            | Fine indexing/rotation (0=default)                            | proportional           |
| <b>22</b>                  |                  | <b>Prism wheel 1</b>  |                        |
|                            |                  | <i>This wheel is blocked If Rotating gobo wheel &gt;0 DMX</i> |                        |
|                            | 0 - 3            | Open position/hole (0=default)                                | step                   |
|                            |                  | <i>Index - set indexing on channel 23</i>                     |                        |
|                            | 4-7              | Prism 1 - 6-facet linear                                      | step                   |
|                            | 8-11             | Prism 2 - 6-facet linear multicoloured                        | step                   |
|                            | 12-15            | Prism 3 - 8-facet 12° circular                                | step                   |
|                            |                  | <i>Rotation - set rotation on channel 23</i>                  |                        |
|                            | 16-19            | Prism 1 - 6-facet linear                                      | step                   |
|                            | 20-23            | Prism 2 - 6-facet linear multicoloured                        | step                   |
|                            | 24-27            | Prism 3 - 8-facet 12° circular                                | step                   |
|                            | 28-255           | Reserved  |                        |
| <b>23</b>                  |                  | <b>Prism wheel 1 indexing/rotation</b>                        |                        |
|                            |                  | <i>Prism indexing - set position on channel 22</i>            |                        |
|                            | 0 - 255          | Prism indexing  | proportional           |
|                            |                  | <i>Prism rotation - set position on channel 22</i>            |                        |
|                            | 0                | No rotation   | step                   |
|                            | 1 - 127          | Forwards prism rotation from fast to slow                     | proportional           |
|                            | 128              | No rotation (128=default)                                     | step                   |
|                            | 129-255          | Backwards prism rotation from slow to fast                    | proportional           |
| <b>24</b>                  |                  | <b>Prism wheel 2</b>  |                        |

DMX protocol

| <b>Mode/Total channels</b> |                  | <b>Function</b>   | <b>Type of control</b> |
|----------------------------|------------------|---|------------------------|
| <b>1/37</b>                | <b>DMX Value</b> |   |                        |
|                            | 0 - 3            | Open position/hole (0=default)  | step                   |
|                            |                  | <b><i>Index - set indexing on channel 25</i></b>                                |                        |
|                            | 4-7              | Prism 1 - 6-facet linear  | step                   |
|                            | 8-11             | Prism 2 - 32-facet circular   | step                   |
|                            | 12-15            | Prism 3 - 8-facet 18° circular  | step                   |
|                            |                  | <b><i>Rotation - set rotation on channel 25</i></b>                             |                        |
|                            | 16-19            | Prism 1 - 6-facet linear  | step                   |
|                            | 20-23            | Prism 2 - 32-facet circular   | step                   |
|                            | 24-27            | Prism 3 - 8-facet 18° circular  | step                   |
|                            | 28-255           | Reserved  |                        |
| <b>25</b>                  |                  | <b>Prism wheel 2 indexing/rotation</b>  |                        |
|                            |                  | <b><i>Prism indexing - set position on channel 24</i></b>                       |                        |
|                            | 0 - 255          | Prism indexing  | proportional           |
|                            |                  | <b><i>Prism rotation - set position on channel 24</i></b>                       |                        |
|                            | 0                | No rotation   | step                   |
|                            | 1 - 127          | Forwards prism rotation from fast to slow                                       | proportional           |
|                            | 128              | No rotation (128=default)   | step                   |
|                            | 129-255          | Backwards prism rotation from slow to fast                                      | proportional           |
| <b>26</b>                  |                  | <b>Pattern selection</b>  |                        |
|                            |                  | <i>Following channels are not active: Prism Wheel 1/2, Prism Wheel 1/2 rot.</i> |                        |
|                            | 0-3              | Open position/hole (0=default)  | step                   |
|                            |                  | <b><i>Index - set indexing on channel 27</i></b>                                |                        |
|                            | 4-5              | Pattern 1   | step                   |
|                            | 6-7              | Pattern 2   | step                   |
|                            | 8-9              | Pattern 3   | step                   |
|                            | 10-11            | Pattern 4   | step                   |
|                            | 12-13            | Pattern 5   | step                   |
|                            | 14-15            | Pattern 6   | step                   |
|                            | 16-17            | Pattern 7   | step                   |
|                            | 18-19            | Pattern 8   | step                   |
|                            | 20-21            | Pattern 9   | step                   |
|                            | 22-23            | Pattern 10  | step                   |
|                            | 24-25            | <i>Pattern 11</i>   | step                   |
|                            | 26-27            | <i>Pattern 12</i>   | step                   |
|                            |                  | <b><i>Rotation - set rotation on channel 27</i></b>                             |                        |
|                            | 28-29            | Pattern 1   | step                   |
|                            | 30-31            | Pattern 2   | step                   |
|                            | 32-33            | Pattern 3   | step                   |
|                            | 34-35            | Pattern 4   | step                   |
|                            | 36-37            | Pattern 5   | step                   |
|                            | 38-39            | Pattern 6   | step                   |
|                            | 40-41            | Pattern 7   | step                   |
|                            | 42-43            | Pattern 8   | step                   |
|                            | 44-45            | Pattern 9   | step                   |
|                            | 46-47            | Pattern 10  | step                   |
|                            | 48-49            | <i>Pattern 11</i>   | step                   |
|                            | 50-51            | <i>Pattern 12</i>   | step                   |
|                            |                  | <b><i>Dynamic patterns-set rotation on channel 27</i></b>                       |                        |

DMX protocol

| <b>Mode/Total channels</b> |                  | <b>Function</b>  | <b>Type of control</b> |
|----------------------------|------------------|--|------------------------|
| <b>1/37</b>                | <b>DMX Value</b> |  |                        |
|                            | 52-53            | Pattern 13   | step                   |
|                            | 54-55            | Pattern 14   | step                   |
|                            | 56-57            | Pattern 15   | step                   |
|                            | 58-59            | Pattern 16   | step                   |
|                            | 60-61            | Pattern 17   | step                   |
|                            | 62-63            | Pattern 18   | step                   |
|                            | 64-65            | <i>Pattern 19</i>  | step                   |
|                            | 66-67            | <i>Pattern 20</i>  | step                   |
|                            | 68-255           | Raw DMX  | proportional           |
| <b>27</b>                  |                  | <b>Pattern rotation and indexing</b>   |                        |
|                            |                  | <i>Following channels are not active: Prism Wheel 1/2, Prism Wheel 1/2 rot.</i>  |                        |
|                            |                  | <b>Pattern indexing - set position on channel 26</b>   |                        |
|                            | 0 - 255          | Pattern indexing   | proportional           |
|                            |                  | <b>Pattern rotation - set position on channel 26</b>   |                        |
|                            | 0                | No rotation  | step                   |
|                            | 1 - 127          | Forwards pattern rotation from fast to slow  | proportional           |
|                            | 128              | No rotation (128=default)  | step                   |
|                            | 129-255          | Backwards pattern rotation from slow to fast   | proportional           |
| <b>28</b>                  |                  | <b>SpektraBeam (Beam effects)</b>  |                        |
|                            |                  | <i>When SpektraBeam is used, the following channels are not active: Zoom, Prism Wheel 1/2, Prism Wheel 1/2 rot., Static gobo, Rot. Gobo gobo, Rot. Gobo Rotation (for Effects 13,14,15 only: Cyan, Magenta, Yellow )</i> |                        |
|                            |                  | <b>All effects were done at max. zoom (0 DMX) and focus = 211 DMX</b>  |                        |
|                            | 0 - 3            | Open position/hole (0=default)   | step                   |
|                            |                  | <b>Index - set indexing on channel 29</b>  |                        |
|                            | 4-5              | Effect 1   | step                   |
|                            | 6-7              | Effect 2   | step                   |
|                            | 8-9              | Effect 3   | step                   |
|                            | 10-11            | Effect 4   | step                   |
|                            | 12-13            | Effect 5   | step                   |
|                            | 14-15            | Effect 6   | step                   |
|                            | 16-17            | Effect 7   | step                   |
|                            | 18-19            | Effect 8   | step                   |
|                            | 20-21            | Effect 9   | step                   |
|                            | 22-23            | Effect 10  | step                   |
|                            | 24-25            | Effect 11  | step                   |
|                            | 26-27            | Effect 12  | step                   |
|                            |                  | <i>Effects 13, 14, 15 block Cyan, Magenta and Yellow channels</i>  |                        |
|                            | 28-29            | Effect 13  | step                   |
|                            | 30-31            | Effect 14  | step                   |
|                            | 32-33            | Effect 15  | step                   |
|                            |                  | <b>Rotation - set rotation on channel 29</b>   |                        |
|                            | 34-35            | Effect 1   | step                   |
|                            | 36-37            | Effect 2   | step                   |
|                            | 38-39            | Effect 3   | step                   |
|                            | 40-41            | Effect 4   | step                   |
|                            | 42-43            | Effect 5   | step                   |
|                            | 44-45            | Effect 6   | step                   |

DMX protocol

| Mode/Total channels |           | Function   | Type of control |
|---------------------|-----------|--|-----------------|
| 1/37                | DMX Value |  |                 |
|                     | 46-47     | Effect 7   | step            |
|                     | 48-49     | Effect 8   | step            |
|                     | 50-51     | Effect 9   | step            |
|                     | 52-53     | Effect 10  | step            |
|                     | 54-55     | Effect 11  | step            |
|                     | 56-57     | Effect 12  | step            |
|                     |           | <i>Effects 13, 14, 15 block Cyan, Magenta and Yellow channels</i>  |                 |
|                     | 58-59     | Effect 13  | step            |
|                     | 60-61     | Effect 14  | step            |
|                     | 62-63     | Effect 15  | step            |
|                     | 64-255    | Reserved   |                 |
| <b>29</b>           |           | <b>SpektraBeam rotation and indexing</b>   |                 |
|                     |           | <i>When SpektraBeam is used, the following channels are not active: Zoom, Prism Wheel 1/2, Prism Wheel 1/2 rot., Static gobo, Rot. Gobo gobo, Rot. Gobo Rotation (for Effects 13,14,15 only: Cyan, Magenta, Yellow )</i> |                 |
|                     |           | <b>SpektraBeam effect indexing - set position on channel 28</b>  |                 |
|                     | 0 - 255   | SpektraBeam effect indexing  | proportional    |
|                     |           | <b>SpektraBeam effect rotation - set position on channel 28</b>  |                 |
|                     | 0         | No rotation  | step            |
|                     | 1 - 127   | Forwards SpektraBeam effect rotation from fast to slow   | proportional    |
|                     | 128       | No rotation (128=default)  | step            |
|                     | 129-255   | Backwards SpektraBeam effect rotation from slow to fast  | proportional    |
| <b>30</b>           |           | <b>Frost</b>   |                 |
|                     | 0-3       | Open (0=default)   | step            |
|                     | 4-7       | 100% Frost   | step            |
|                     | 8-255     | Reserved   | proportional    |
| <b>31</b>           |           | <b>Zoom****</b>  |                 |
|                     | 0 - 255   | Zoom from max. to min.beam angle (128=default)   | proportional    |
| <b>32</b>           |           | <b>Zoom - fine</b>   |                 |
|                     | 0-255     | Fine zooming (0=default)   | proportional    |
| <b>33</b>           |           | <b>Focus****</b>   |                 |
|                     | 0 - 255   | Continuous adjustment from far to near (128=default)   | proportional    |
| <b>34</b>           |           | <b>Focus - fine</b>  |                 |
|                     | 0- 255    | Fine focusing (0=default)  | proportional    |
| <b>35</b>           |           | <b>Shutter/ strobe</b>   |                 |
|                     | 0 - 31    | Shutter closed   | step            |
|                     | 32 - 63   | Shutter open (32=default)  | step            |
|                     | 64 - 95   | Strobe-effect from slow to fast  | proportional    |
|                     | 96 - 127  | Shutter open   | step            |
|                     | 128 - 143 | Opening pulse in sequences from slow to fast   | proportional    |
|                     | 144 - 159 | Closing pulse in sequences from fast to slow   | proportional    |
|                     | 160 - 191 | Shutter open   | step            |
|                     | 192 - 223 | Random strobe-effect from slow to fast   | proportional    |
|                     | 224 - 254 | Shutter open   | step            |
|                     | 255       | Shutter closed   | step            |
| <b>36</b>           |           | <b>Dimmer intensity</b>  |                 |
|                     | 0 - 255   | Dimmer intensity from 0% to 100% (0=default)   | proportional    |
| <b>37</b>           |           | <b>Dimmer intensity - fine</b>   |                 |

DMX protocol

| <b>Mode/Total channels</b>  |                  | <b>Function</b>          | <b>Type of control</b> |
|---|------------------|--------------------------|------------------------|
| <b>1/37</b>   | <b>DMX Value</b> |                          |                        |
|   | 0 - 255          | Fine dimming (0=default) | proportional           |
| <b>**** The iBolt's internal safety system does not allow some combinations of zoom and focus, please see</b> |                  |                          |                        |
| <b>the User manual, chapter " 4.8 Allowed zoom/focus positions".</b>  |                  |                          |                        |
| Copyright © 2023 -2025 Robe Lighting s.r.o. - All rights reserved   |                  |                          |                        |
| All Specifications subject to change without notice   |                  |                          |                        |