

ROBE

T15 PCTM

T15 FresnelTM

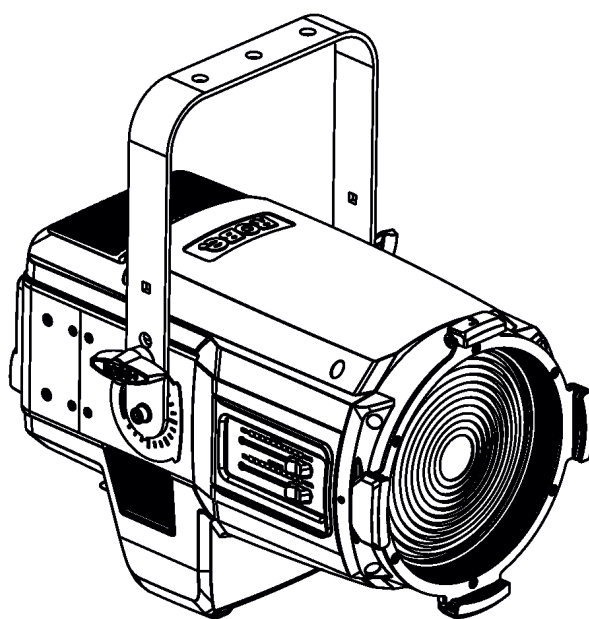

ROBE
Innovative
Technology

QR code for user manual



USER MANUAL

ROBE[®] lighting s.r.o. • Czech Republic • www.robe.cz

Version 1.0

T15 PC

T15 Fresnel

Table of contents

1. Safety instructions	3
2. Operating determination	4
3. Fixture exterior view and control elements	6
4. Installation	7
4.1 Connection to the mains	7
4.2 Changing the front lens	8
4.3 Barndoors module installation	9
4.4 Yoke length change	10
4.5 Pole operated yoke installation	11
4.6 Rigging the fixture	15
4.7 DMX-512 connection	17
4.8 Ethernet connection	18
4.9 Wireless DMX operation	19
5. Remotely controllable functions	20
5.1 Colour influencing functions	20
5.2 Motorized effect functions	22
6. Control menu map	23
7. Control menu	26
7.1 Simple mode	27
7.3 Standard mode	30
7.3.1 DMXA (Addressing)	30
7.3.2 Info (Fixture information)	30
7.3.3 Pers(Personality)	31
7.3.4 Manual Control (Manual)	33
7.3.5 Test program (Test Prg)	33
7.3.6 Stand-alone (St Alone)	33
7.3.7 Reset	34
7.3.8 Special functions (Special)	34
8. RDM	37
9. Robe Ethernet Access Portal (REAP)	37
10. Error and information messages	38
11. Technical Specifications	39
12. Maintenance and cleaning	41
12.1 Disposing of the product	42
13. ChangeLog	42
14. Appendix	43
14.1 Changing the LED light source	43
14.2 Obtaining information about the LED light source by mobile phone	47

CAUTION!

***Keep this device away from rain and moisture!
Unplug mains lead before opening the housing!***

**FOR YOUR OWN SAFETY, PLEASE READ THIS USER MANUAL CAREFULLY
BEFORE YOU INITIAL START - UP!**

1. Safety instructions

Please use only an original ROBE packaging (paper box, loader case or foam shell) for transporting the device, otherwise potential damage of the device during its transport will not subject to warranty.

CAUTION!

***Be careful with your operations.
With a high voltage you can suffer
a dangerous electric shock when touching the wires!***

This device has left our premises in absolutely perfect condition. In order to maintain this condition and to ensure a safe operation, it is absolutely necessary for the user to follow the safety instructions and warning notes written in this manual.

The manufacturer will not accept liability for any resulting damages caused by the non-observance of this manual or any unauthorized modification to the device.

Please consider that damages caused by manual modifications to the device are not subject to warranty.

Make sure that the available voltage is not higher than stated on the rear panel.

WARNING! This unit does not contain an ON/OFF switch. Always disconnect power input cable to completely remove power from unit when not in use or before cleaning or servicing the unit.

Make sure that the power cord is never crimped or damaged by sharp edges. Check the device and the power-cord from time to time.

Always disconnect from the mains, when the device is not in use or before cleaning it. Only handle the power-cord by the plug. Never pull out the plug by tugging the power cord.

This device falls under protection class I. Therefore it is essential to connect the yellow/green conductor to earth. The electric connection, repairs and servicing must be carried out by a qualified employee.

Do not connect this device to a dimmer pack.

Do not touch the device's housing bare hands during its operation (housing becomes hot)!

For replacement use fuses of same type and rating only.

***LED light emission. Risk of eye injury.
Do not look straight at the fixture's LED source during operation. The intense light beam may damage your eyes.***

***Do not view the light output with optical instruments or any device that may concentrate the beam.
The light source contains blue LEDs.***

CAUTION! Risk group 2, RG-2



2. Operating determination

This device is a moving head for creating decorative effects and was designed for indoor use only. This device is for professional use only. It is not for household use.

If the device has been exposed to drastic temperature fluctuation (e.g. after transportation), do not switch it on immediately. The arising condensation water might damage your device. Leave the device switched off until it has reached room temperature.

When choosing the installation spot, please make sure that the device is not exposed to extreme heat, moisture or dust. There should not be any cables lying around. You endanger your own and the safety of others!

Make sure that the area below the installation place is blocked when rigging, derigging or servicing the fixture.

Always fix the fixture with an appropriate safety wire. Fix the safety wire at the correct hole only.

Only operate the fixture after having checked that the housing is firmly closed and all screws are tightly fastened.

The maximum ambient temperature 45°C must never be exceeded.

CAUTION!

The front lens has to be replaced when it is obviously damaged, so that its function is impaired, e. g. due to cracks or deep scratches!

Operate the device only after having familiarized with its functions. Do not permit operation by persons not qualified for operating the device. Most damages are the result of unprofessional operation!

Do not block the front objective lens with any object when the fixture is under operation.

The fixture housing never must be covered with cloth or other materials.

Please use the original packaging if the device is to be transported.

Please consider that unauthorized modifications on the device are forbidden due to safety reasons!

If this device will be operated in any way different to the one described in this manual, the product may suffer damages and the guarantee becomes void. Furthermore, any other operation may lead to dangers like short-circuit, burns, electric shock, burns etc.

CAUTION!

To avoid damage of the internal parts of the fixture head, never let the sunlight lights directly to the front lens , even when the fixture is not working !

The product (covers and cables) must not be exposed to a high frequency electromagnetic field higher than 3V/m.

Immunity of the equipment is designed according to the standard EN 55035 Electromagnetic compatibility of multimedia equipment - Immunity requirements

Emission of the equipment complies with the standard EN55032 Electromagnetic compatibility of multimedia equipment – Emission Requirements according to class B.

This device complies with part 15 of the FCC Rules. Operation is subject to the following two conditions: (1) This device may not cause harmful interference, and (2) this device must accept any interference received, including interference that may cause undesired operation.

Changes or modifications not expressly approved by the party responsible for compliance could void the user's authority to operate the equipment.

The [Device] wireless operation is safe and complies to RF Exposure requirements

This equipment has been tested and found to comply with the limits for a Class B digital device, pursuant to part 15 of the FCC Rules. These limits are designed to provide reasonable protection against harmful interference in a residential installation. This equipment generates, uses and can radiate radio frequency energy and, if not installed and used in accordance with the instructions, may cause harmful interference to radio communications. However, there is no guarantee that interference will not occur in a particular installation. If this equipment does cause harmful interference to radio or television reception, which can be determined by turning the equipment off and on, the user is encouraged to try to correct the interference by one or more of the following measures:

- Reorient or relocate the receiving antenna.
- Increase the separation between the equipment and receiver.
- Connect the equipment into an outlet on a circuit different from that to which the receiver is connected.
- Consult the dealer or an experienced radio/TV technician for help.

3. Fixture exterior view and control elements

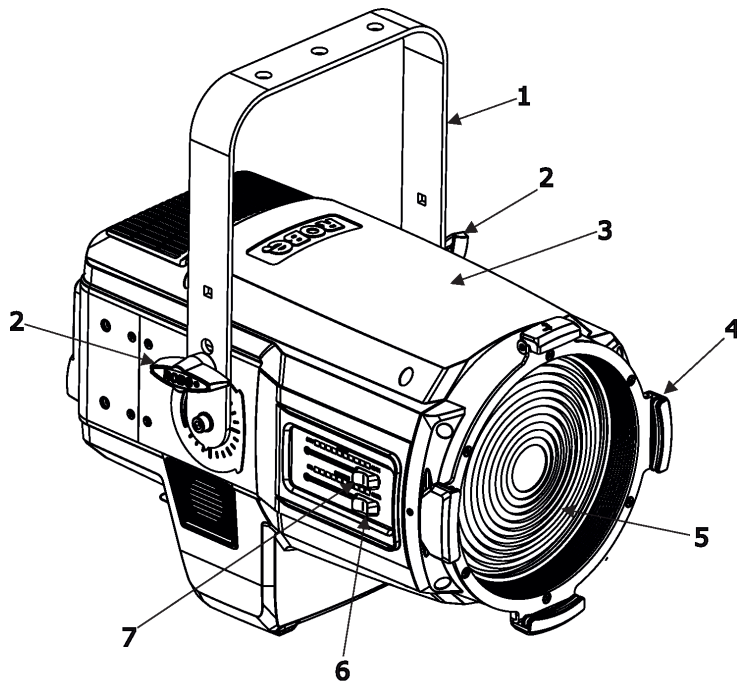

- 1 - Mounting yoke
- 2 - Tilt locks
- 3 - Top cover
- 4 - Gel frame adaptor
- 5 - Front lens (Fresnel or PC)
- 6 - Fader Intensity
- 7 - Fader Zoom

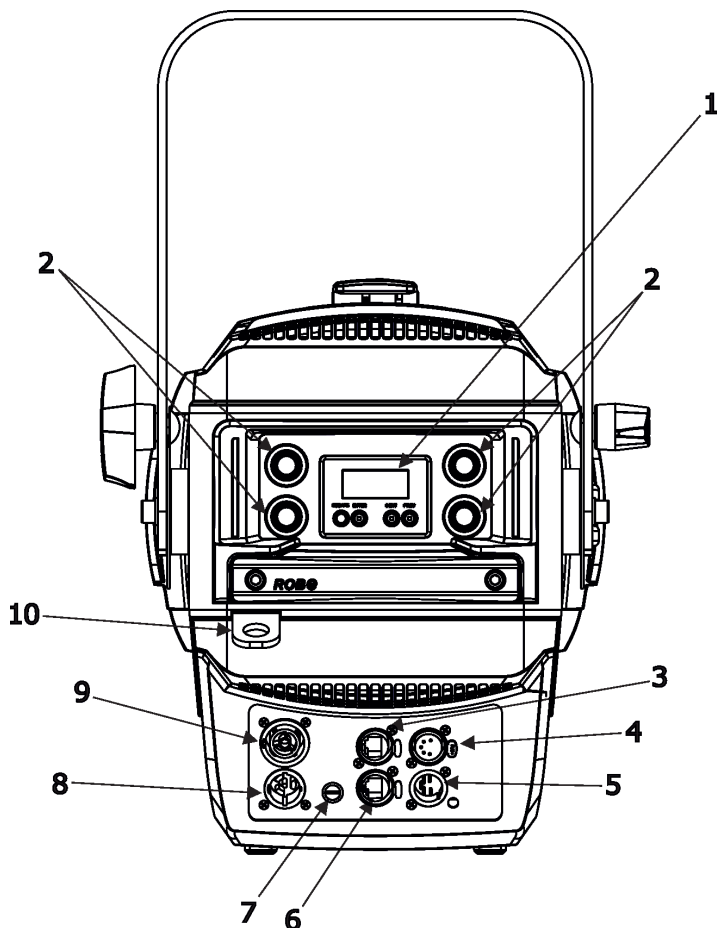

Rear side of the fixture

- 1 - Display
- 2 - control knobs
- 3 - Ethernet Out (EP version only)
- 4 - 5-pin DMX Out
- 5 - 5-pin DMX In
- 6 - Ethernet In
- 7 - Fuse holder
- 8 - Power In (PowerCon True 1)
- 9 - Power Out (PowerCon True 1)
- 9 - Power Out (PowerCon True 1)
- 10 - Attachment point for safety wire
- 11 - Yoke
- 12 - Framing shutters lock

4. Installation



Fixtures must be installed by a qualified electrician in accordance with all national and local electrical and construction codes and regulations.

4.1 Connection to the mains

For protection from electric shock, the fixture must be earthed!

The fixture is equipped with auto-switching power supply that automatically adjusts to any 50-60Hz AC power source from 100-240 Volts.

Power cable is enclosed to the fixture. If you need to install a power plug on the power cable to allow connection to power outlets, install a grounding-type (earthed) plug, following the plug manufacturer's instructions. If you have any doubts about proper installation, consult a qualified electrician.

Core (EU)	Core (US)	Connection	Plug Terminal Marking
Brown	Black	Live	L
Light blue	White	Neutral	N
Yellow/Green	Green	Earth	PE/GND

This device falls under class one and must be earthed (grounded).

Design of the ROBIN T15 allows you to connect several fixtures to AC mains power in one interconnected daisy chain using power input and throughput connectors. Needed daisy chain cords are stated in the chapter "Technical specifications"

Maximum number of linked fixtures depends on input voltage:

CE:

7 fixtures at power supply= 230V

6 fixtures at power supply= 208V

4 fixtures at power supply= 120V

US:

5 fixtures at power supply= 230V

5 fixtures at power supply= 208V

3 fixtures at power supply= 120V

Real numbers of fixtures may differ from values stated above as you have to take into account the length of supply cables, circuit breaker etc. at projecting of the fixtures installation Do not overload the supply line and connecting leads.

4.2 Changing the front lens

***Install the front lens with the device unplug from mains.
The front lens is heavy!***

1. Disconnect the fixture from mains and allow it to cool.
2. Loosen four screws (2) on the lens module (1), loosen the securing wire (3) and remove the lens module (1), e.g. PC lens module from the fixture. Be careful, the lens module is heavy!
3. Place the new lens module e.g. Fresnel lens module on the fixture, screw the securing wire (3) and fasten the lens module by means of the four screws (2). Check that all screws are fully tightened.

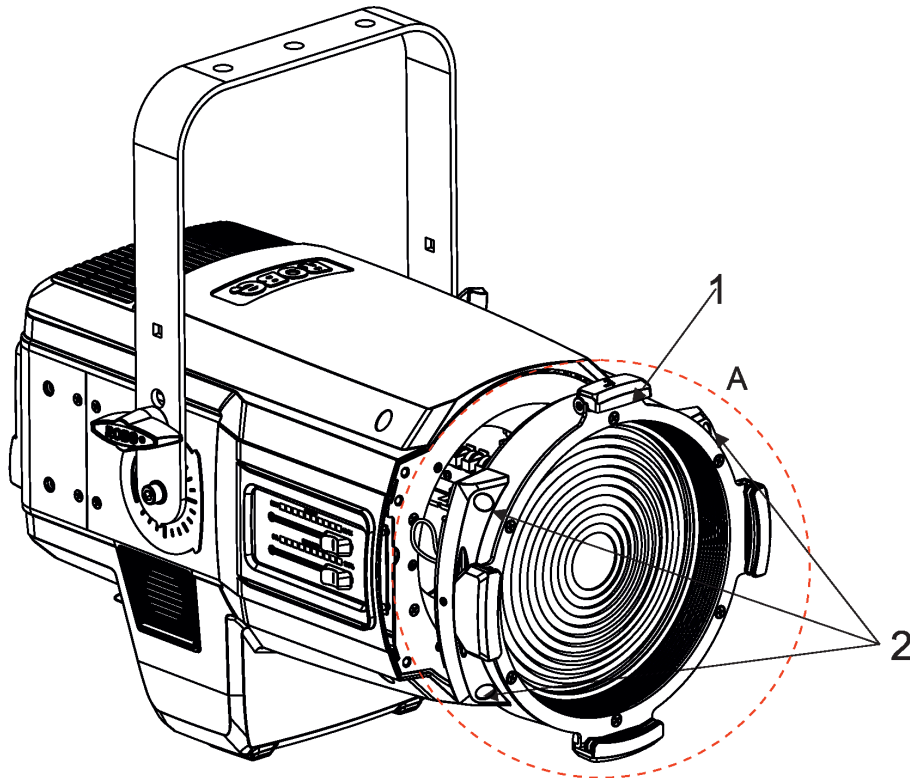

Detail A

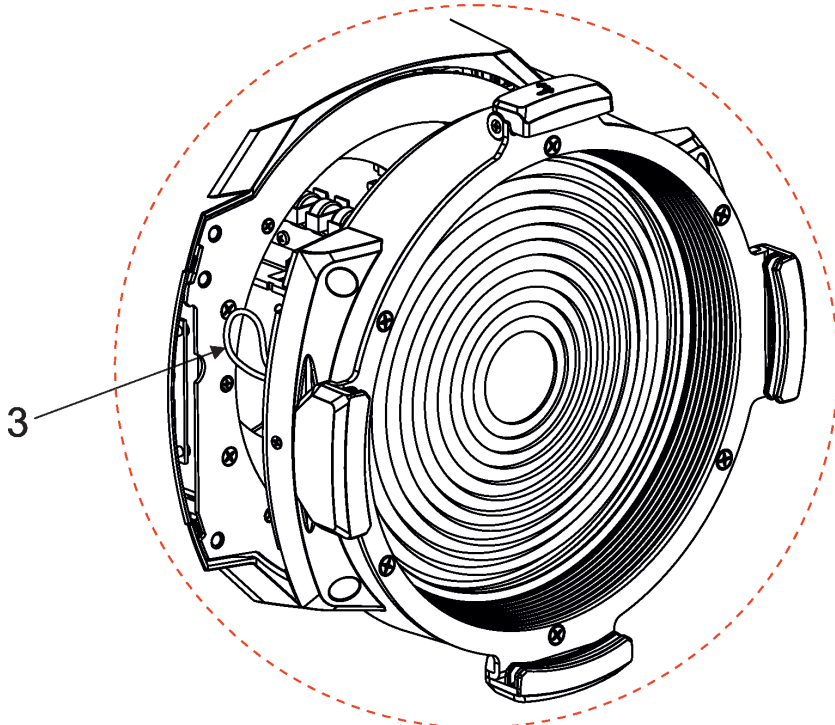

4.3 Barndoors module installation

Unplug the fixture from mains before barndoors module installation!

1. Disconnect the fixture from mains and allow it to cool.
2. Move the lock (1) to unlock position .
3. Insert the barndoors module (2) into grooves in the holders (3).
4. Secure the barndoor module in the grooves by the barndoor lock (1).
5. Check the barndoor lock (1) is fully in the locked position.

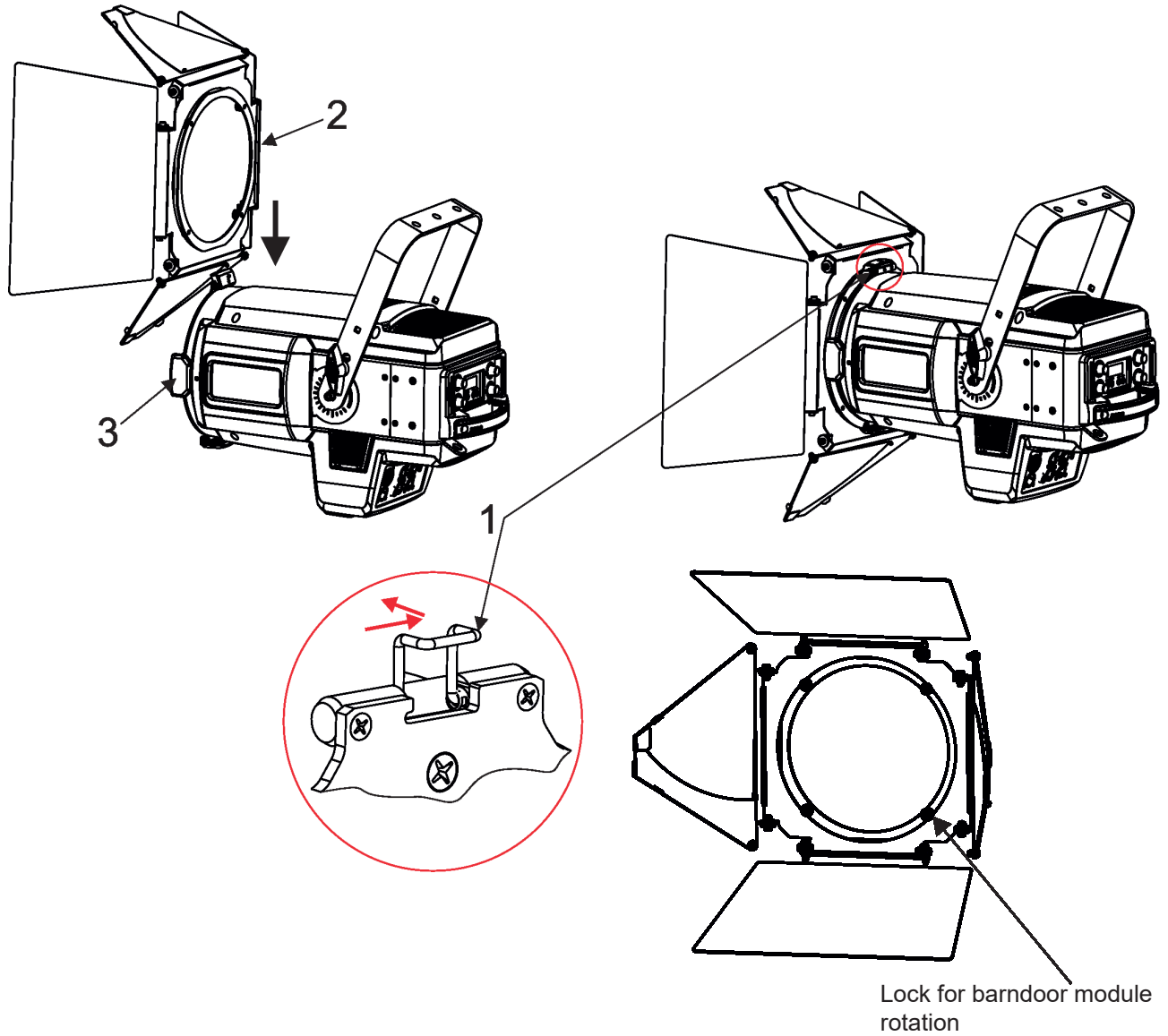

4.4 Yoke length change

Unplug the fixture from mains before yoke installation!

The yoke of the fixture can be "shortened" about 70 mm by means of fastening the fixture via the hole B instead of the hole A (default).

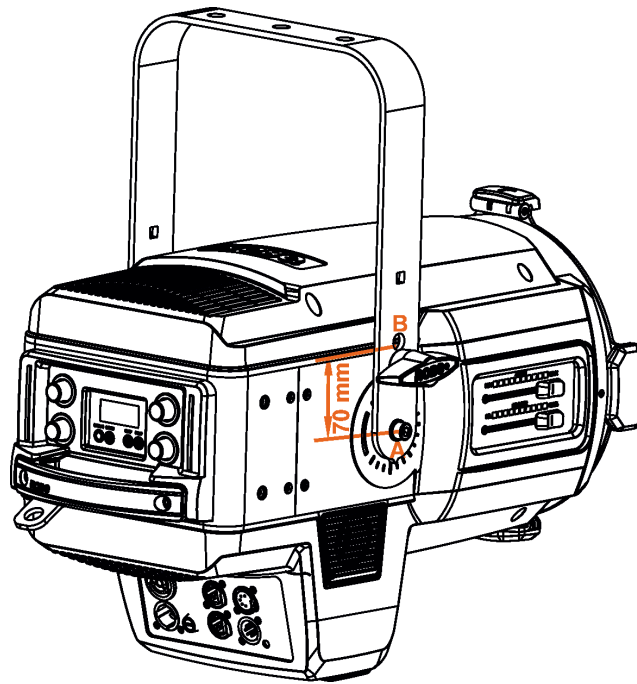

To install the yoke via the hole position B

1. Disconnect the fixture from mains and allow it to cool.
2. Remove the yoke (1) from the fixture by unscrewing two tilt locks (2) and two hexagon socket screws M8x16 (5) with washers (4) and spacers (3)
3. Install the yoke (1) to the fixture via the hole B. Proceed in the reverse order of as at uninstillation the yoke (1).
4. Check that both hexagon socket screws M8x16 (5) and tilt locks (2) are sufficiently tightened before hanging the fixture

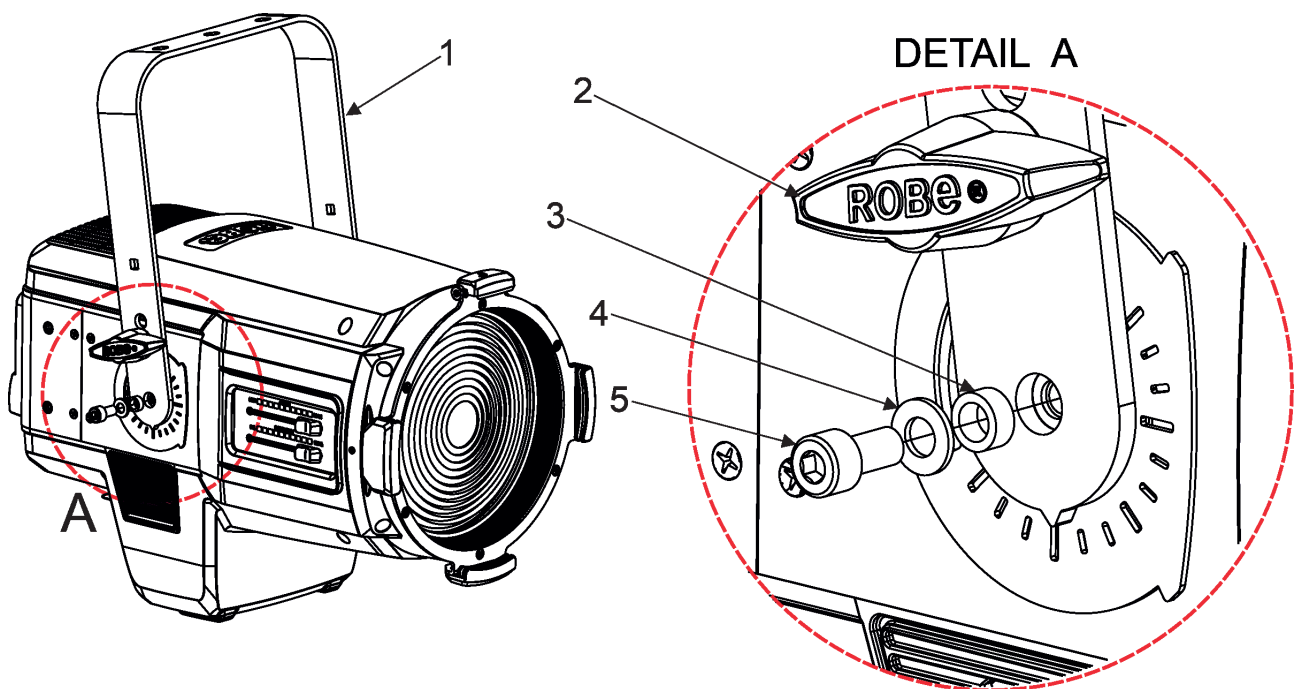

4.5 Pole operated yoke installation

Unplug the fixture from mains before pole operated yoke installation!

1. Disconnect the fixture from mains and allow it to cool.
2. Remove the original yoke (1) from the fixture by unscrewing two tilt locks (2) and two hexagon socket screws M8x16 (5) with washers (4) and spacers (3)

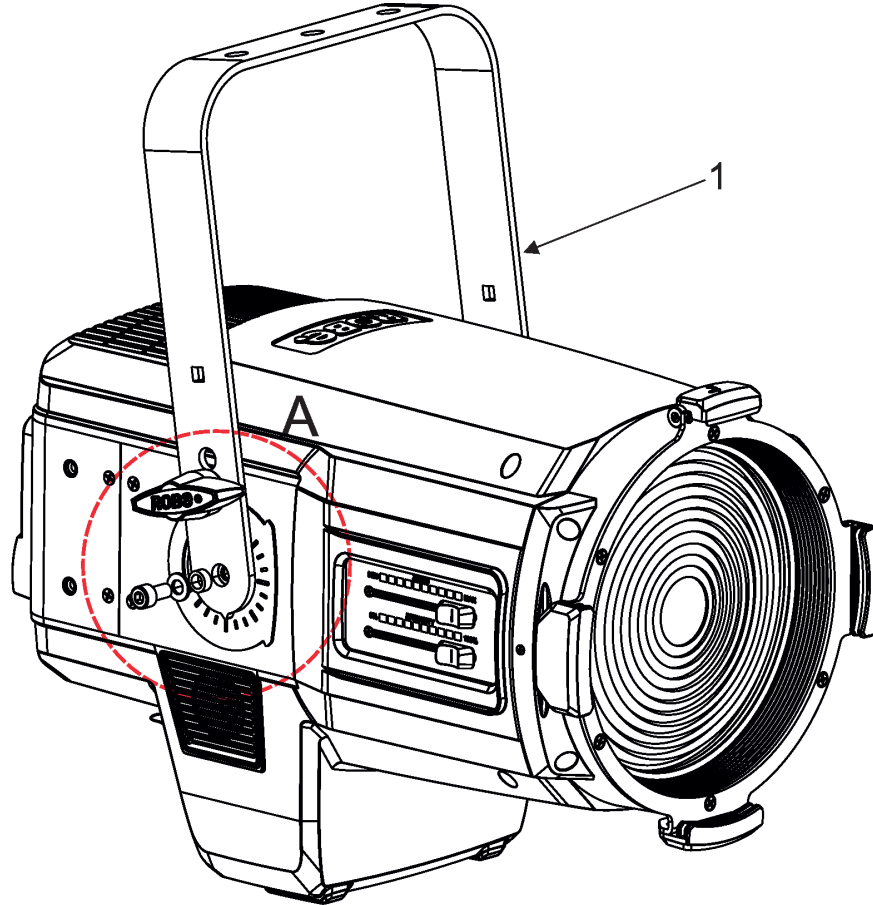

DETAIL A

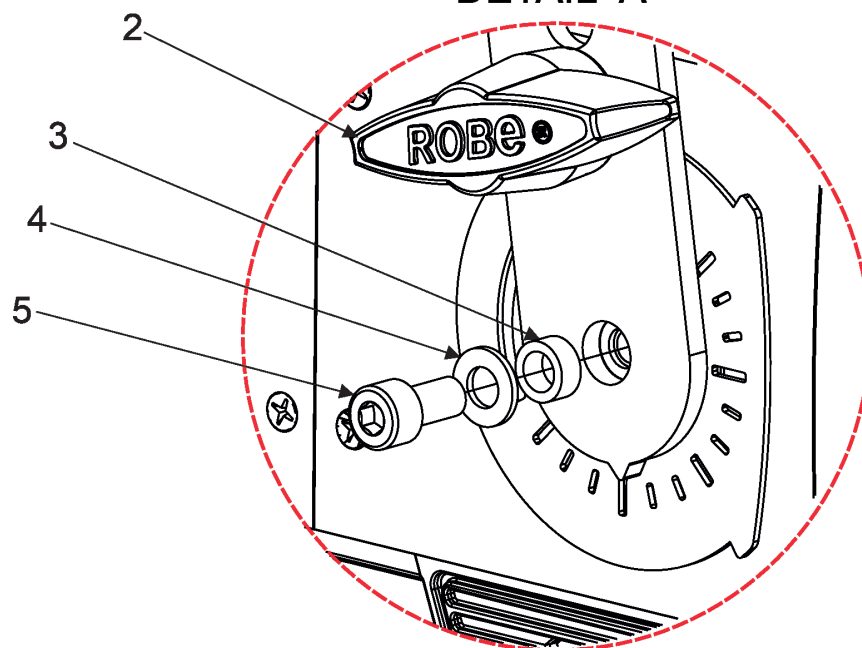

3. Remove circular holders (6) by unscrewing four flat head screws M3x6 (7) on each holder.

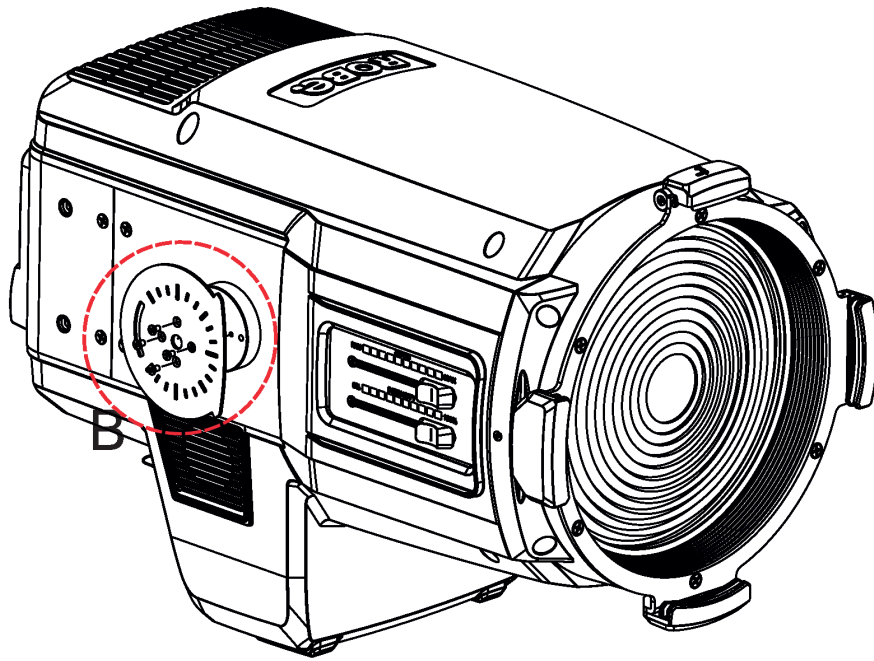

DETAIL B

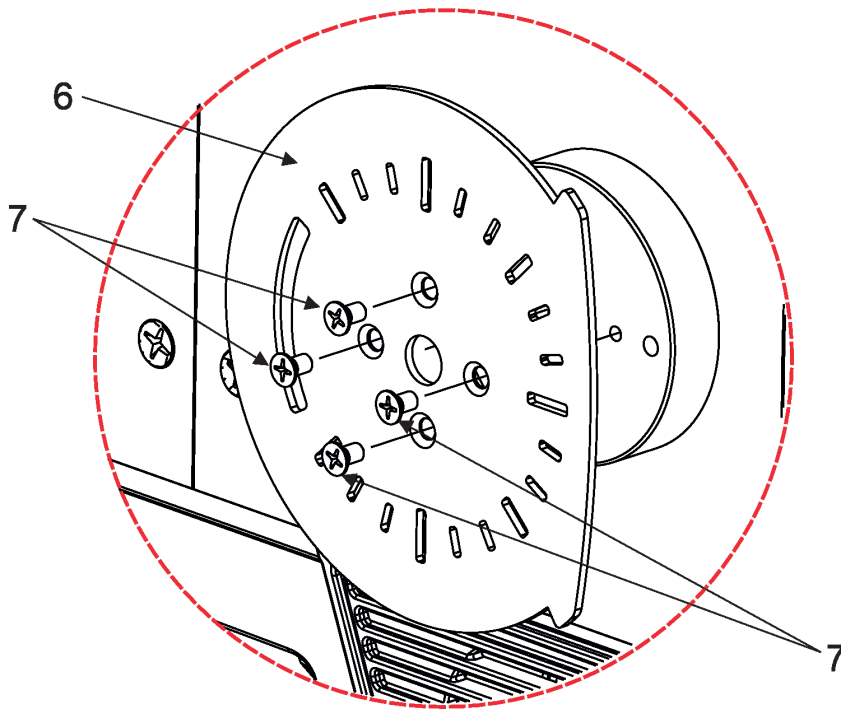

4. Screw one side of the pole operated yoke (8) on the side of the fixture by means of the hexagon socket screw M8x16 (9) with washer (10) and by means of three flat head screws M4x8 (11).

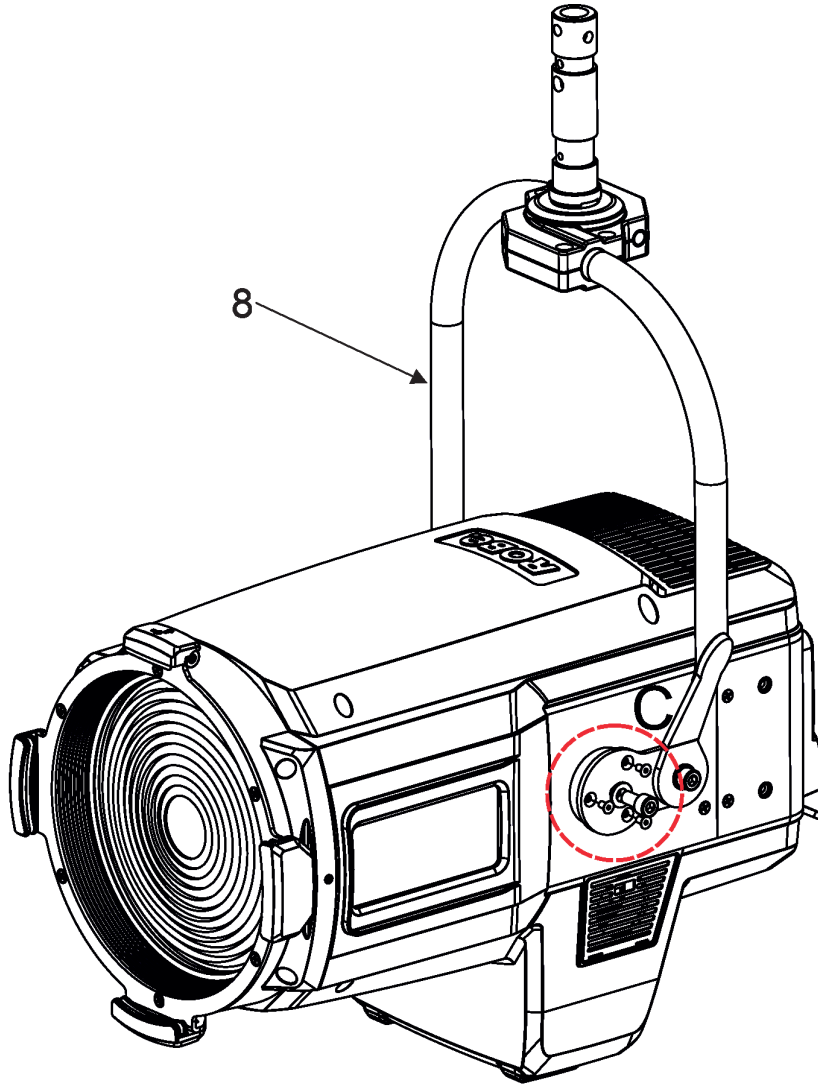

DETAIL C

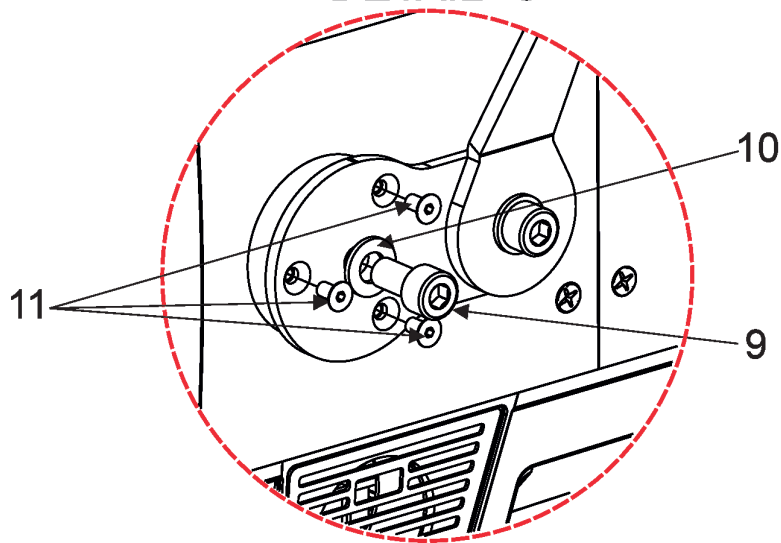

5. Screw the second side of the pole operated yoke (8) on the side of the fixture by means of the hexagon socket screw M8x16 (9) with washer (10) and by means of three flat head crews M4x8 (11).

Note: The hexagon socket screws M8x16 (9) with washer (10) and flat head crews M4x8 (6) are parts of the pole operated yoke delivery.

Check the all screws are firmly tightened before taking the fixture to operation with the pole operated yoke.

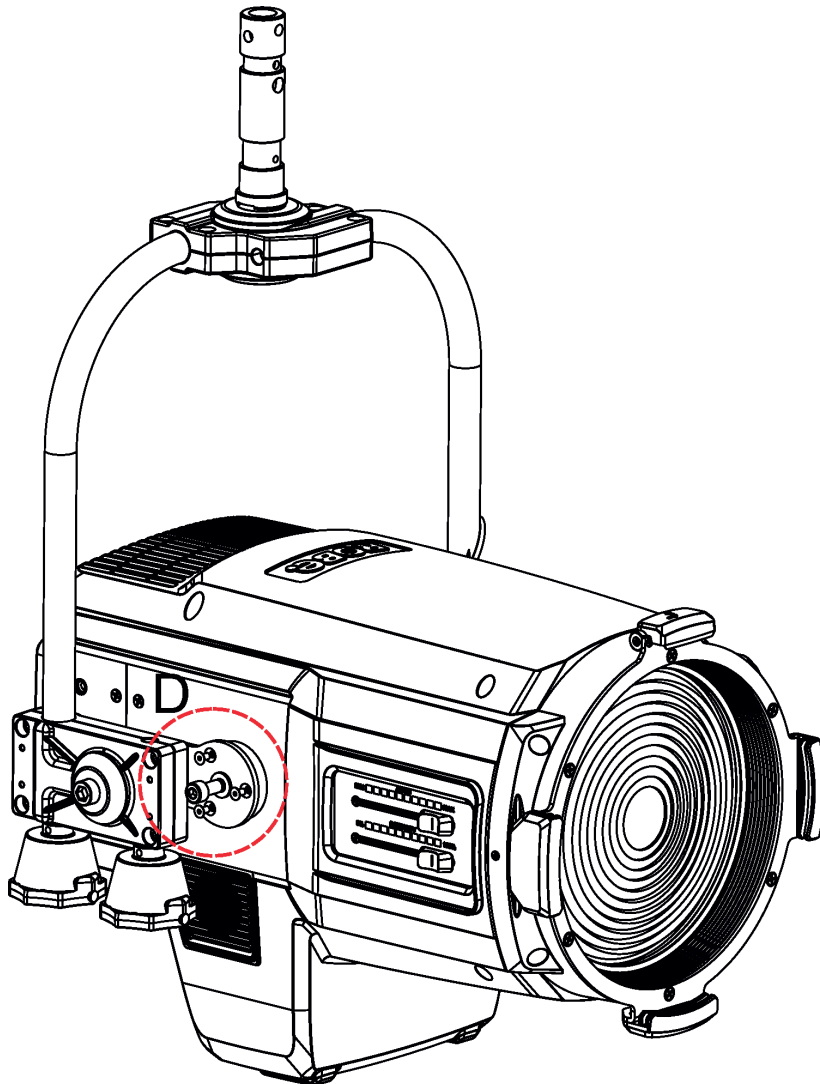

DETAIL D

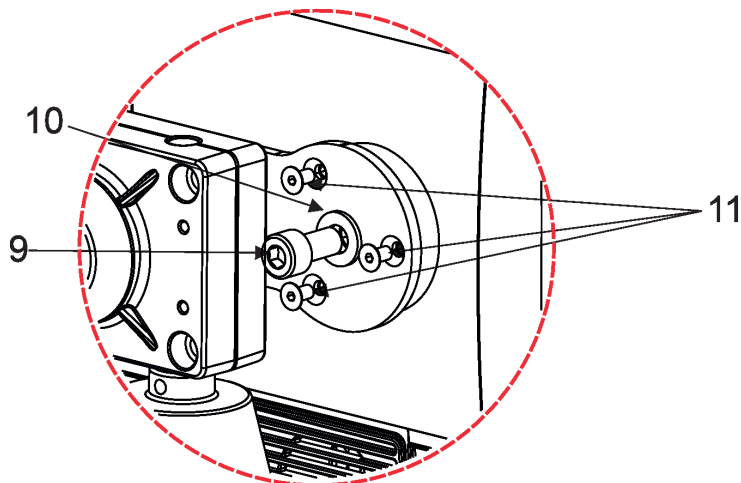

4.6 Rigging the fixture

A structure intended for installation of the fixture(s) must safely hold weight of the fixture(s) placed on it. The structure has to be certificated to the purpose.

The fixture (fixtures) must be installed in accordance with national and local electrical and construction codes and regulations.

For overhead installation, the fixture must be always secured with a safety wire that can bear at least 10 times the weight of the fixture

When rigging, derigging or servicing the fixture staying in the area below the installation place, on bridges, under high working places and other endangered areas is forbidden.

The operator has to make sure that safety relating and machine technical installations are approved by an expert before taking into operation for the first time and after changes before taking into operation another time.

The operator has to make sure that safety relating and machine technical installations are approved by a skilled person once a year.

Allow the fixture to cool for ten minutes before handling.

The projector should be installed outside areas where persons may walk by or be seated.

IMPORTANT! OVERHEAD RIGGING REQUIRES EXTENSIVE EXPERIENCE, including calculating working load limits, installation material being used, and periodic safety inspection of all installation materials and the fixture. If you lack these qualifications, do not attempt the installation yourself, but use a help of professional companies.

CAUTION: Fixtures may cause severe injuries when crashing down! If you have doubts concerning the safety of a possible installation, do not install the fixture!

The fixture has to be installed out of the reach of public.

The fixture must never be fixed swinging freely in the room.

***Danger of fire !
When installing the device, make sure there is no highly inflammable material (decoration articles, etc.) in a distance of min. 0.5 m.***

***CAUTION!
Use an appropriate clamp to rig the fixture on the truss.
Make sure that the device is fixed properly!
Ensure the structure (truss) to which you are attaching the fixtures is secure.***

The fixture can be placed directly on the stage floor or rigged in any orientation on a truss without altering its operation characteristics .

For securing the fixture to the truss, install a safety wire which can hold at least 10 times the weight of the fixture.

Truss installation

1. Bolt clamp (1) to the yoke (2) with M12 bolt and lock nut through the hole in the yoke.
3. Clamp the fixture on a truss (3) and tighten the rigging clamp (1).
4. Pull one safety wire (4) around the truss (2) and lock it. Lock the second end of the safety wire in the attachment point (5) as shown on the picture below. Use only the safety wire with a snap hooks with screw lock gates.

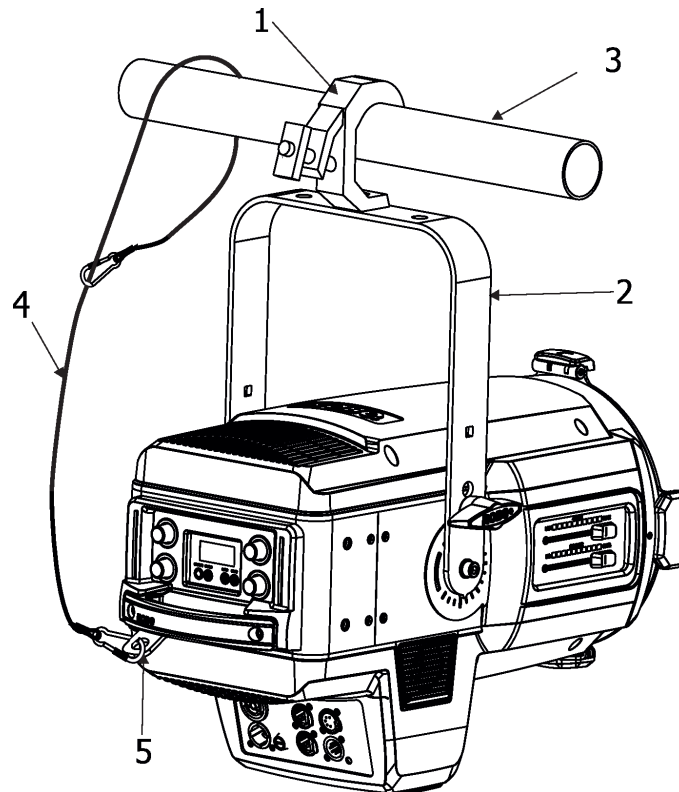

***When installing fixtures side-by-side,
avoid illuminating one fixture with another!***

DANGER TO LIFE!
***Before taking into operation for the first time, the installation has to be approved by
an expert!***

4.7 DMX-512 connection

The fixture is equipped with 5-pin XLR sockets for DMX input and output. The sockets are wired in parallel. Only use a shielded twisted-pair cable designed for RS-485 and 5-pin XLR-plugs and connectors in order to connect the controller with the fixture or one fixture with another.

DMX output

XLR socket (female)



- 1 - Shield
- 2 - Signal (-)
- 3 - Signal (+)
- 4 - Not connected
- 5 - Not connected

DMX input

XLR socket (male)

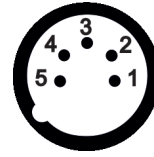

- 1 - Shield
- 2 - Signal (-)
- 3 - Signal (+)
- 4 - Not connected
- 5 - Not connected

If you are using the standard DMX controllers, you can connect the DMX output of the controller directly with the DMX input of the first fixture in the DMX chain. If you wish to connect DMX controllers with other XLR outputs, you need to use adaptor cables.

Building a serial DMX chain

Connect the DMX output of the first fixture in the DMX chain with the DMX input of the next fixture. Always connect one output with the input of the next fixture until all fixtures are connected. Up to 32 fixtures can be connected.

Caution: At the last fixture, the DMX cable has to be terminated with a terminator. Solder a 120 Ω resistor between Signal (-) and Signal (+) into a 3-pin XLR-plug and plug it in the DMX output of the last fixture.

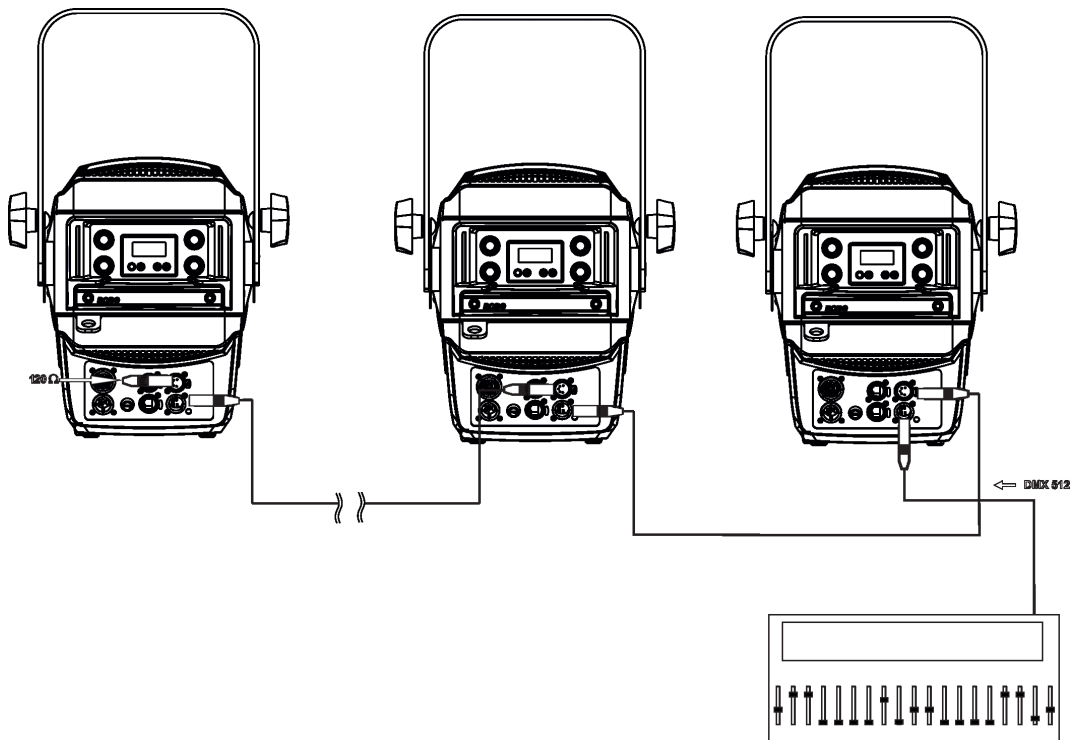

4.8 Ethernet connection

The fixtures on a data link are connected to the Ethernet with ArtNet communication protocol. The control software running on your PC (or light console) has to support Art-Net protocol.

Art-Net communication protocol is a 10 Base T Ethernet protocol based on the TCP/IP. Its purpose is to allow transfer of large amounts of DMX 512 data over a wide area using standard network technology.

IP address is the Internet protocol address. The IP uniquely identifies any node (fixture) on a network.

The Universe is a single DMX 512 frame of 512 channels.

The Robin T15 is equipped with 8-pin RJ-45 sockets for Ethernet connection. Use a network cable category 5 (with four "twisted" wire pairs) and standard RJ-45 plugs in order to connect the fixture to the network.

RJ-45 socket (front view):



- | | |
|------------------|------------------|
| 1- TD+ | 5- Not connected |
| 2- TD- | 6- RX- |
| 3- RX+ | 7- Not connected |
| 4- Not connected | 8- Not connected |

RJ-45 plug (front view):



Patch cables that connect fixtures to the hubs or LAN sockets are wired 1:1, that is, pins with the same numbers are connected together:

1-1	2-2	3-3	4-4	5-5	6-6	7-7	8-8
-----	-----	-----	-----	-----	-----	-----	-----

If only the fixture and the computer are to be interconnected, no hubs or other active components are needed. A cross-cable has to be used:

1-3	2-6	3-1	4-8	5-7	6-2	7-5	8-4
-----	-----	-----	-----	-----	-----	-----	-----

Connect the Ethernet inputs of all fixtures with the Ethernet network.

Option "Artnet" (gMa1 or gMA2 or sACN) has to be selected from "Ethernet Mode" menu at each fixture.

Set IP address (002.xxx.xxx.xxx / 010.xxx.xxx.xxx) and the Universe at each fixture.

Example:

(DMX address=225)
IP address=002.168.002.004
Universe=1

(DMX address=25)
IP address=002.168.002.003
Universe=1

(DMX address=1)
IP address=002.168.002.002
Universe=1

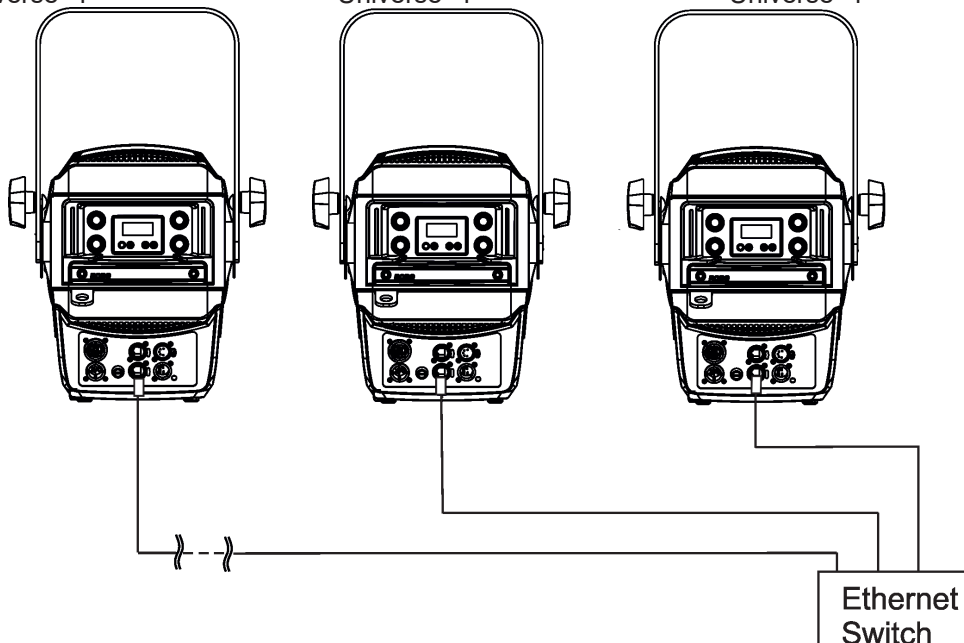

An advised PC setting: IP address: 002.xxx.xxx.xxx (Different from fixture IP addresses)
NET mask: 255.0.0.0

The EP version of the fixture is equipped with two RJ 45 sockets and Ethernet Pass Through Switch which sustains Ethernet integrity, when the fixture has no power, it automatically maintains network connectivity. If you use the Ethernet IN-OUT way for the Ethernet connection, max. 8 fixtures can be connected in the IN-OUT line.

4.9 Wireless DMX operation

The external ROBE Wireless DMX/RDM module allows receiving wireless DMX. The ROBE wireless DMX/RDM module has full support for wireless communication protocols at entertainment market. Modul is based on well known LumenRadio RF technology, with implemented wire interface for connection with Robe products. RF output for MCX interface antenna as standard output.

ROBE Wireless DMX/RDM Module

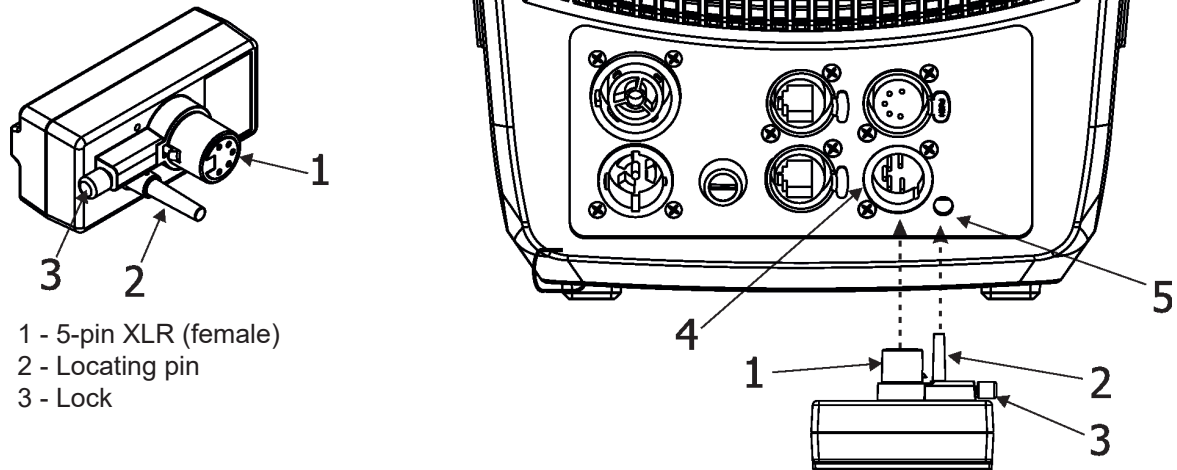

Push in the 5-pin XLR plug (1) into 5-pin XLR socket (4) and simultaneously locating pin (2) into hole (5) in the fixture. In this way the wireless DMX module is connected with the fixture.

NOTE: when you disconnect the DMX wireless module from fixture, press and hold lock (5) during getting the wireless module out.

To link the fixture with DMX transmitter.

The fixture can be only linked with the transmitter by running the link procedure at DMX transmitter .

After linking , the level of DMX signal (0-100 %) is displayed in the menu item "Stat" (Special -->Wireless -->Stat).

To unlink the fixture from DMX transmitter.

The fixture can be unlinked from transmitter via the menu item " Unlink" (Special-->Wireless -->Unlink.).

5. Remotely controllable functions

5.1 Colour influencing functions

Factory setting of menu functions (channels) which influence behaviour of colour channels is the following:

Function	Factory setting	Function	Factory setting
DMX mode	1	Uniformity	Off
Colour calibration mode	On	Colour mix control	0 DMX
Colour mixing mode	CMY	CTC	110 DMX (5600K)
Dimmer curve	Super square law	CRI Selection	High (255 DMX)
Tungsten effect simulation	Off	Green correction	Uncorrected (128 DMX)
Chromatic white	Off	Shutter/Strobe	Open (32 DMX)
Light output stability	Off	Dimmer	Closed (0 DMX)

Colour calibration mode (menu "Pers-->Col. Cal.")

The function switches on/off an internal control of colours. For a standard operation of the fixture the option should be switched on. Option off has to be set during colour calibration of the fixture (in this mode some functions e.g. Tungsten effect, Virtual colour wheel are disabled).

Colour mixing system (menu "Pers-->Col. Mix", DMX channel "Colour functions")

This item allows selection between RGB and CMY mode. In 3-colour controlling modes (Mode 1, Mode 2) all internal 5 colours are always utilized where possible.

Dimmer curve (menu "Pers-->Dimmer C". DMX channel "Colour functions")

The fixture allows you to select a dimmer curve: linear, square law or super square law.

Tungsten effect simulation (menu "Pers-->Tungsten", DMX channel "Colour functions")

The function simulates behaviour of a halogen lamp during dimming at calibrated white colours 2700K - 4200K. You can select from various lamp wattage simulation: 750W, 1000W, 1200W, 2000W, 2500W. If the function Chromatic white is on, the Tungsten effect will influence also mixed colours.

Saving user colours (DMX channel "Colour functions")

To save user colours:

1. Set the function White Point to off (Channel Colour Mix Control, range 70-79 DMX).
1. Mix desired colour on colour channels.
2. Stay in desired position of user colours (216-235 DMX) on the Virtual colour wheel for 1 sec.
3. Leave the range of user colours (216-235 DMX) on the Virtual colour wheel.
4. Repeat steps 2-4 for next user colour.
5. To permanently save user colours, stay for 3 sec. at DMX range of 110-114 on the channel Colour functions. After that the colour system will be reset (this action can last about 2 minutes). Previous user colours will be overwritten.

Chromatic white (menu "Pers-->Chro. W.", DMX channel "Colour functions")

If the function is on, the CTC channel influences calibrated white colours and mixed colours (also colours on Virtual colour wheel).

If the function is off, the CTC channel influences calibrated whites only.

Light output stability (menu "Pers-->Li O.S.", DMX channel "Colour functions")

If the function is on, the light output from the fixture is immediately reduced to a value corresponding to a thermal drop of the light intensity from the LED engine (the thermal drop of light intensity - decreasing of the light intensity on circa 90 % of starting level after first 5 minutes, then is the thermal drop of light intensity inconsiderable).

Output Uniformity (menu "Pers-->O. Uni.", DMX channel "Colour functions")

If the function is on, the light intensity from the fixture is corrected in order to get approximately the same light intensity as from another fixture which has also the function on. Thanks to the function, light outputs from more fixtures will have approximately the same light intensity.

Colour Mix control (DMX channel "Colour Mix control")

The Colour Mix control channel defines relation between colour channels (Cyan, Magenta, Yellow, Red, Green, Blue, Amber, Lime and CTC) and the colours on the virtual colour wheel:

DMX value	Function
0 - 9	Virtual colour wheel has priority over colour channels (default setting)
10-19	Maximum mode (highest values have priority)
20-29	Minimum mode (lowest values have priority)
30-39	Multiply mode (multiply virtual colour wheel and colour channels)
40-49	Addition mode (virtual colour wheel + colour channels)
50-59	Subtraction mode (virtual colour wheel – colour channels)
60-69	Inverted Subtraction mode (virtual colour wheel – colour channels)
70-79	White Point Off (CTC+green correction+virtual col. wheel deactivated)
80-128	Reserved
129	Crossfade Virtual colour wheel only
130-254	Crossfade between virtual colour wheel and colour channels
255	Crossfade colour channels only

CTC (DMX channel " CTC")

The CTC channel allows you to change a colour temperature of calibrated white colours in range of 8000K-2700K and also can influence mixed colours including colours on the Virtual colour wheel.

For correct function of the CTC channel on calibrated white colours, the following conditions have to be kept:

1. The Colour calibration mode has to be set on (*menu "Pers-->Col. Cal. -->On"*).
If the Chromatic white is set off, the CTC channel influences white colours only.
If the Chromatic white is set on, the CTC channel influences white colours and mixed colours including colours on the Virtual colour wheel.
2. The following channels have to be set at:
 - Virtual colour wheel at 0 DMX
 - Green correction at 128 DMX
 - Colour mix control channel at 0 DMX

3. Colour channels have to be set depending on the colour mixing mode and the DMX mode.

CMY colour mixing mode.

DMX mode 1:

Channels Cyan/Red, Magenta/Green and Yellow/Blue (both 8-bit and 16-bit channels for each colour) have to be set at 0 DMX or at the same DMX value (except 255 DMX).

DMX mode 2

Channels Cyan/Red, Magenta/Green and Yellow/Blue have to be set at 0 DMX or at the same DMX value (except 255 DMX) .

DMX mode 3:

The mode is not intended for CMY colour mixing mode.

RGB(A,L) colour mixing mode

DMX mode 1:

Channels Cyan/Red, Magenta/Green and Yellow/Blue (both 8-bit and 16-bit channels for each colour) have to be set at 255 DMX or at the same DMX value (except 0 DMX).

DMX mode 2:

Channels Cyan/Red, Magenta/Green and Yellow/Blue have to be set at 255 DMX or at the same DMX value (except 0 DMX).

DMX mode 3:

Channels Red, Green, Blue, Amber and Lime (both 8-bit and 16-bit channels for each colour) have to be set at 255 DMX or at the same DMX value (except 0 DMX).

4. Shutter and dimmer have to be open.

CRI selection (DMX channel " CRI Selection")

The channel allows you to set CRI from Low (80) to High (90+). Default setting is 255 DMX (High CRI).

Green correction (DMX channel "Green correction ")

The channel allows you a fine correction of colours (whites, mixed colours, colours on the Virtual colour wheel).
E.g. white colour from red to green tint.

Virtual colour wheel (DMX channel " Virtual colour wheel")

The virtual colour contains 67 preset colours and 10 user colours.

Dimmer/Shutter (DMX channels " Shutter/Strobe" and "Dimmer Intensity")

Smooth 0 - 100 % dimming is provided by the electronic control unit of the light source. The control of the light source also allows strobe effects with variable speed.

5.2 Motorized effect functions

Zoom

Motorized zoom in range of 10° - 72° for both (Fresnel and PC) lenses.

6. Control menu map

Default settings=**Bold print**

Level 1	Level 2	Level 3	Level 4	Level 5	Level 6	Level 7	
DMXA	Set DMXA	001-512					
	DMX Pres.	Mode 1					
		:					
		Mode 6					
	IP Addr	Def addr	Set Address				
		Cus addr	IP 1	0-255			
			IP 2	0-255			
			IP 3	0-255			
			IP 4	0-255			
			Set Address				
	NEt Mask	N.M. 1	0-255				
		N.M. 2	0-255				
		N.M. 3	0-255				
		N.M. 4	0-255				
		Set Net M.					
	GateWay	Gw 1					
		Gw 2					
		Gw 3					
		Gw 4					
		Set GateW.					
	Info	PO Time	Total				
			Reset				
LOTi		R LOT					
		G LOT					
		B LOT					
		A LOT					
		L LOT					
DMX Val		Powr					
		:					
		Dimm F					
Temps		Base Tmp	Current				
			Highest				
			High Res				
		LB1 Tmp	Current				
			Highest				
			High Res				
		LB2 Tmp	Current				
			Highest				
			High Res				
		LEDs Tmp	Current				
			Highest				
			High Res				
IP Addr		IP A. 1					
	IP A. 2						
	IP A. 3						
	IP A. 4						
MAC Addr	MAC A. 1						
	:						
	MAC A. 6						
RDM UID	RDM U. 1						
	:						
	RDM U. 6						

Level 1	Level 2	Level 3	Level 4	Level 5	Level 6	Level 7
	Sw Ver	IC-D				
		IC-DE				
		IC-L1				
		IC-L2				
		IC-L3				
		IC-O				
		IC-DL				
		IC-POT				
Pers	DMX Pres	Mode 1				
		:				
		Mode 6				
	DMX In	Wired				
		Ethernet				
	Ethernet	Eth Mode	ArtNet			
			sACN			
			gMA I			
			gMA II			
		ArtNet	Uni	0-255		
		sACN	Uni	1-63999		
		MANet	Uni	1-256		
			sID	1-32		
		IGMP r	Off			
			1-10s			
		Eth Back	Off, On			
	Display	Turn				
		On/Off T	On, Off			
		Contrast	0-100%			
		Backlight	0-100%			
	Fans	Fans Mode	Auto			
			Quiet			
		BLC Fans	On, Off			
		Noise L.	0%-100%			
	Tungsten	Off				
		750W				
		1000W				
		1200W				
		2000W				
		2500W				
	Col Mix	RGB				
		CMY				
	White P.	On, Off				
	Dimmer C	Sqrl				
		SuSqrl				
		Line				
	Opt Br	On, Off				
	Li. O.s.	Off, On				
	Chro. W.	On, Off				
	O. Uni	On, Off				
	LED Freq.	300				
		600				
		1200				
		2400				
		High				
	LED F.adj-126-1, 0, 1...126				

Level 1	Level 2	Level 3	Level 4	Level 5	Level 6	Level 7
	Temp Uni	°C, °F				
	I Ef Pos	Powr				
		:				
		Dimm F				
		Store				
	User Col.	View Col.	U col 1			
			:			
			U col 10			
		Dist Col				
	Res Wpas					
	Defaults					
Manual		Powr	0-255			
		:				
		Dimm F	0-255			
Test Prg						
St Alone	Music T	On, Off				
	Auto Run	Off				
		Test				
		Prog 1				
		Prog 2				
		Prog 3				
	Pr Play	Test Prg				
		Prog 1				
		Prog 2				
		Prog 3				
	Pr Edit	Prog 1	Step 1	Powr		
		Prog 2	:	:		
		Prog 3	Step 40	F.Tim	0-25.5	
				S.Tim	0-25.5	
				COPY		
				Prg En	1-40	
Reset						
Special	RDM Low					
	RDM Hight					
	Adjust	DMX Val	Powr	0-255		
	*Wireless	Stat				
		Unlink				
			:			
			Dimm F	0-255		
		Calib	Cal Mech	Zoom C	0-255	
				Store		
			Cal. Col.	Red C.	R X,R Y, R I,R T	
				Gre C.	G X,G Y, G I,G T	
				Blu C.	B X,B Y, B I,B T	
				Amb C.	A X,A Y, A I,A T	
				LiG C.	L X,L Y, L I,L T	
				Green Corr	2700K I-8000K I	100-155
					2700K C-8000K C	100-155
				Store		
			LEDs Cur			
			Cal Load	No, Yes		
	Sw Upd	No, Yes				

* with Wireless DMX/RDM module only

7. Control menu

The Robin T15 is equipped with the two-row LCD display & 4 control buttons which allow you to set fixture's behaviour according to your needs, obtain information on its operation, control all range of effects and program it in the stand-alone mode. The four control knobs have functions according function modes.

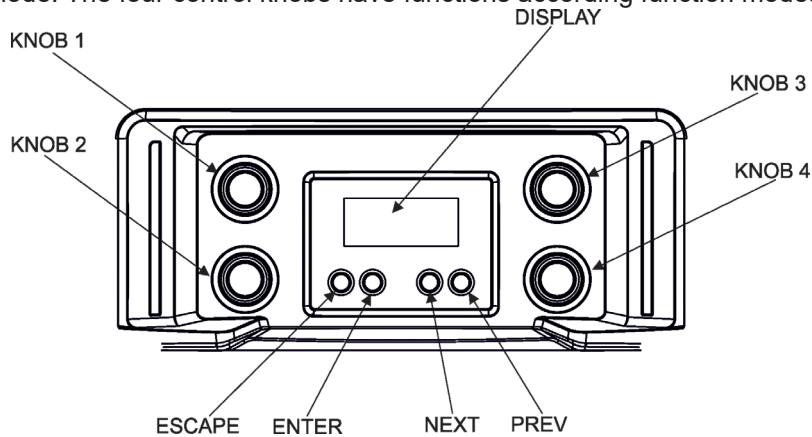

Control buttons on the front panel:

ESCAPE button used to leave the menu without saving changes.

NEXT and PREV buttons for moving between menu items and symbols, adjusting values.

ENTER button used to enter the selected menu item and to confirm adjusted value.

Sliders

Two sliders on the side of the fixture allows you precise control of functions mapped on them.

Both sliders are active in the Simple mode only.

Default mapping is the following: Slider 1-Zoom

Slider 2-Intensity

Please see the following chapter "Simple mode" how to map function on desired slider.

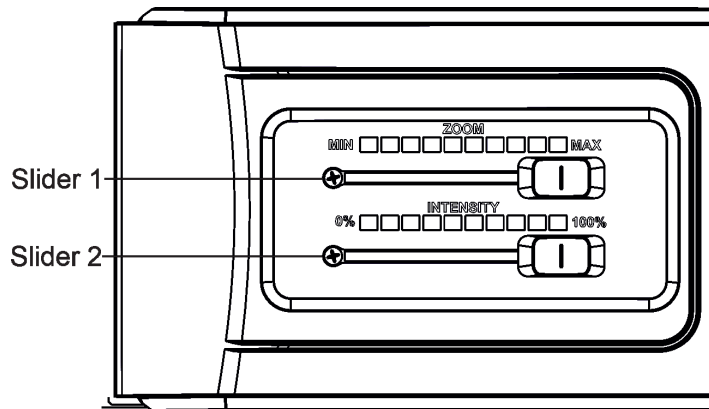

Note.

Intensity and colour of backlight of sliders and control knobs can be set by means of the control page 4 in the Simple mode.

7.1 Simple mode

In the Simple mode, the fixture is controlled by means of four control knobs and the fixture's effects cannot be controlled by DMX.

To enter the Simple mode, press any control knob for two seconds and the first page of the Simple mode will be displayed on the screen with controllable items next to corresponding knobs. After pressing desired knob, its blinking value will be displayed and can be changed by the knob. Adjusted value can be saved by pressing matching knob. To switch to the second page, press the NEXT button. To return to previous page, press the PREV button, to leave the Simple mode, press the ESCAPE button.

Control pages overview:

Page 1

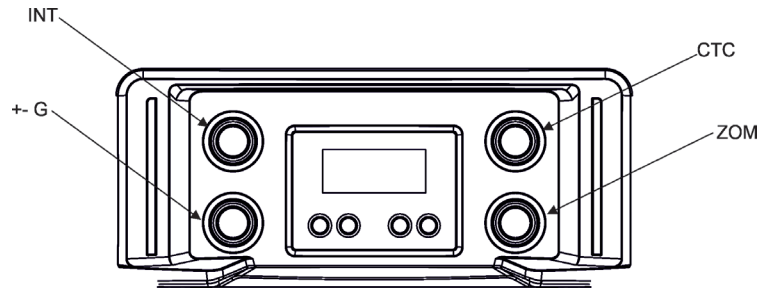

INT (Light Intensity), values: 0%-99%, MAX
Default = MAX

+ - G (Green correction), values: -99 - +99
Default=0

CTC (Colour Temperature Correction), values: 2700-8000K
Default=2700K

ZOM (Zoom), values: 0%-99%, MAX
Default=0%

Page 2

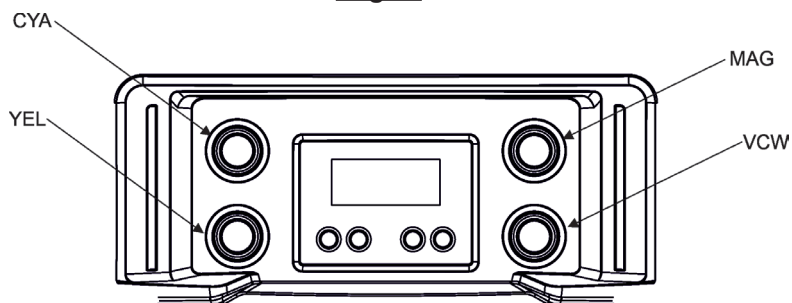

CYA (Cyan), values:0%-99%, MAX
Default=0%

YEL (Yellow), values:0%-99%, MAX
Default =0%

MAG (Magenta), values:0%-99%, MAX
Default =0%

VCW (Virtual Colour Wheel), values: NOF, 4, 10, 19...793,
(4, 10, 19...numbers of colours)
Default=NOF (no function)

Page 3

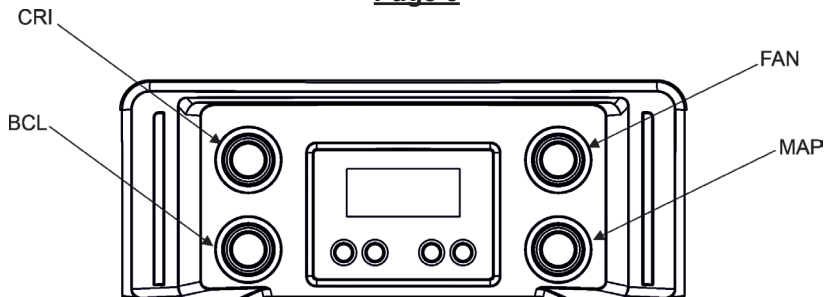

CRI (Colour Rendering Index),
values: MIN, MAX, OPT
Default=MIN

BCL- (Backlight of knobs and faders),
values: OFF, ON
Default=ON

FAN (Fans Operating Mode), values: 1%-99%, MAX
Default=AUTO

MAP (Faders mapping), values: FAD 1, FAD2,
Default: Fader 1= Zoom, Fader 2=Light intensity

To map a function on the fader.

1. Press the knob **MAP**, select fader 1 (FAD 1) or fader 2 (FAD 2), by turning the knob **MAP** and confirm selected fader by pressing the knob **MAP**.
2. By turning the knob **MAP** select a function which you wish to map on selected slider:
 - INT - Light intensity
 - +G - +/- Green
 - ZOM - Zoom
 - CTC - Colour Temperature Correction
 - CYA - Cyan
 - MAG - Magenta
 - YEL - Yellow
3. Confirm selected function by pressing the knob **MAP**.

Page 4

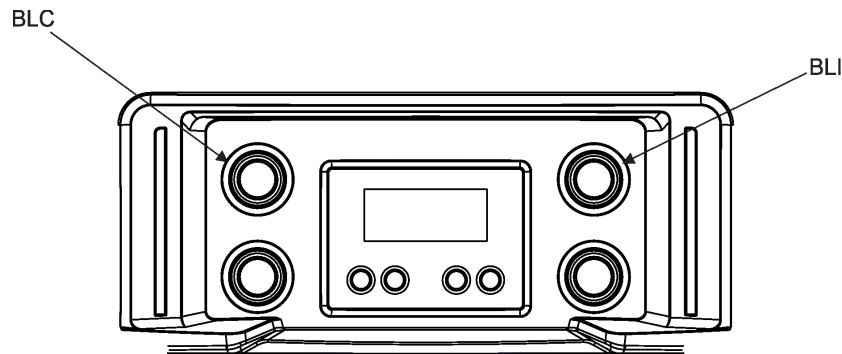

BLC (Knobs and faders Backlight colour),
values: DEF, ALL, RED, GN, BL, WH, CYA
YEL,OR, PK
Default=DEF (default colour)

BLI (Knob and faders backlight Intensity),
values: OFF, 1-100%
Default=OFF

To set colour and intensity of backlight of control knobs and faders.

1. Set the knob **BCL** on the page 3 to "ON".
2. Press the knob **BLI** and set backlight intensity for faders to 50% by turning the knob **BLI**. Confirm it by pressing the knob **BLI**.
3. Press the knob **BLC** and select desired backlight colour for faders by turning the knob **BLC**. Confirm selected colour by pressing the knob **BLC**.
Items on the display:
 - DEF - Default colours
 - RED - Red colour
 - GR- Green colour
 - BL- Blue colour
 - WH - White colour
 - CYA - Cyan colour
 - MAG - Magenta colour
 - YEL - Yellow colour
 - OR- Orange colour
 - PK- Pink colour
 - ALL** - this repeated item after every colour means, that the colour will be used for both faders and knobs.
4. Press the knob **BLI** and set desired backlight intensity for faders (and knobs) by turning the knob **BLI**. Confirm it by pressing the knob **BLI**.

To set values on pages stated above to the default (factory) values, press and hold any two knobs simultaneously for two seconds. During the action you have to be in the Simple mode.

To leave the Simple mode, press any control knob for two seconds or press the ESCAPE button or send DMX command (130-134 DMX) on the channel Power/Special functions.

After leaving the Simple mode, the fixture's effects can be controlled by DMX. If you enter the Simple mode again, values saved in last Simple mode will be recalled.

If the fixture is in the Simple mode switched off and on again, it will remain in the Simple mode.

By pressing any two knobs for two seconds at the same time you will open a light output and the sign "Fast On" will be displayed. During the action you have to be in the standard display menu (you have to leave the Simple mode before it). To close the light output, press any two knobs at the same time for two seconds. This function is useful for fast switching the light output on during adjusting the fixture on a truss.

7.3 Standard mode

The following menu items are accessible in the standard mode only.

7.3.1 DMXA (Addressing)

Set DMXA - Use this menu item to set the DMX start address of the fixture, which is defined as the first channel from which the ROBIN T15 will respond to the controller.

If you set, for example, the address 20, the ROBIN T15 will use channels 20 - 39 for control (if Mode 1 is selected). Please, be sure that you do not have any overlapping channels in order to control each ROBIN T15 correctly and independently from any other fixture on the DMX data link.

Blinking DMX address means that the fixture is either not receiving DMX data or that the set DMX address is higher than allowed, exceeding the DMX footprint of the set DMX mode.

DMX Pres. - **DMX preset.** Use the menu to select desired channel mode.

Mode 1 - 20 control channels

Mode 2 - 10 control channels

Mode 3 - 24 control channels

Mode 4 - 7 control channels

Mode 5 - 2 control channels

Mode 6 - 1 control channel

IP Addr. - **IP address.** Select this menu to set IP address. IP address is the Internet protocol address. The IP address uniquely identifies any node (fixture) on a network.

There cannot be 2 fixtures with the same IP address on the network!

Def. addr. - Default IP address.

Cus. addr. - Custom IP address. You can set up IP address according your needs. The address you can set by each octet (IP1, IP2, IP3, IP4). Confirm by "Set Address"

Net Mask - **Network Mask.** The option enables to set up all bytes of Net Mask by each octet (N.M.1, N.M.2, N.M.3, N.M.4). Confirm by "Set Net M."

GateWay - **Gateway address.** The option enables to set up all bytes of the Gateway address octet (Gw1, Gw.2, Gw.3, Gw.4). Confirm by "Set GateW."

7.3.2 Info (Fixture information)

PO Time - **Power on time.** Select the menu to read the number of fixture operation hours.

Total - The item shows the total number of the operation hours since the ROBIN T15 has been fabricated.

Reset - The item shows the number of the operation hours since the counter was last reset.

In order to reset this counter to 0, press and hold both [NEXT] and [PREV] buttons and the [Enter] button at the same time.

LOTi - **LEDs on time.** Select the menu item to read the number of operation hours of individual LEDs.

R LOT. - Red LEDs on time.

G LOT. - Green LEDs on time.

B LOT. - Blue LEDs on time.

A LOT. - Amber LEDs on time.

L LOT. - Lime LEDs on time.

DMX Val. - **DMX values.** The menu allows you to read DMX values of each channel received by the fixture.

Temps - **Fixture temperatures.** The menu shows temperatures in the fixture.

LEDsTmp. - The menu shows temperature on the LED PCB in the light source

Current - The current temperature of the LED PCB.

Highest - The highest temperature of the LED PCB since the fixture has been fabricated.

High Res. - The highest temperature of the LED PCB since the counter was last reset.

In order to reset this counter to 0, press and hold both [NEXT] and [PREV] buttons and the [Enter] button at the same time.

LB1 Tmp. - The menu shows temperature on the LEDs control PCB (RB 3407-top side) in the fixture.

Current - The current temperature on the LEDs control PCB.

Highest - The highest temperature on the LEDs control PCB since the fixture has been fabricated.

High Res. - The highest temperature on the LEDs control PCB since the counter was last reset.

In order to reset this counter to 0, press and hold both [NEXT] and [PREV] buttons and the [Enter] button at the same time.

LB2 Tmp. - The menu shows temperature on the LEDs control PCB (RB 3407-bottom side) in the fixture.

Current - The current temperature on the LEDs control PCB.

Highest - The highest temperature on the LEDs control PCB since the fixture has been fabricated.

High Res. - The highest temperature on the LEDs control PCB since the counter was last reset.

In order to reset this counter to 0, press and hold both [NEXT] and [PREV] buttons and the [Enter] button at the same time.

Base Tmp. - The menu shows temperature on the display PCB in the fixture.

Current - The current temperature on the display PCB.

Highest - The highest temperature on the display PCB since the fixture has been fabricated.

Highest Res. - The highest temperature on the display PCB since the counter was last reset.

In order to reset this counter to 0, press and hold both [NEXT] and [PREV] buttons and the [Enter] button at the same time.

IP Addr. - **IP address.** The menu allows you to read the IP address of the fixture.

MAC Addr. - **MAC address.** The menu allows you to read the MAC address of the fixture.

RDM UID. - **RDM UID.** The menu allows you to read RDM UID of the fixture.

Sw. Ver. - **Software versions.** Select this item to read the software version of fixture modules.

IC-D - Display processor.

IC-DE - EEprom.

IC-L1 - LEDs control processor 1.

IC-L2 - LEDs control processor 2.

IC-L3 - LEDs control processor 3.

IC-O - Zoom control processor.

IC-DL - Display LEDs control processor.

IC-POT - Faders control processor.

7.3.3 Pers(Personality)

DMX Pres - **DMX preset.** Use the menu to select desired channel mode.

Mode 1 - 20 control channels

Mode 2 - 10 control channels

Mode 3 - 24 control channels

Mode 4 - 7 control channels

Mode 5 - 2 control channels

Mode 6 - 1 control channel

DMX In- **DMX input.** Use the menu to select mode of DMX signal receiving.

Wired - DMX signal is received by means of the standard DMX cable.

Ethernet - DMX signal is received by means of ETHERNET cable.

Ethernet - **Ethernet operation.** The menu allows you to set fixture for Ethernet operation.

Eth Mode - The menu item allows you to select desired protocol:

ArtNet

sACN

gMA I

gMA II

ArtNet - Use the menu item to select desired universe for ArtNet (Uni), range 0-255

sACN - Use the menu item to select desired universe for sACN (Uni), range 1-63999

MANet - Use the menu item to select desired universe (Uni) for MANet, range 0-256 and ID session (SID), range 1-32.

GMP - Use the menu item to set time for connecting to multitask address (1-10sec.) for IGMP protocol.

Eth Back - Ethernet Back-up. If the function is On, the fixture automatically switches to the Ethernet input for signal receiving in case of DMX signal loss. Correct protocol has to be set in the menu "Eth Mode" and the option Wired or Wireless* has to be set in the menu "DMX In".
* If Wireless DMX module is installed.

Display - Display adjusting. This menu allows you to adjust the display behaviour.

Turn - This function turns the display by 180°.

On/Off T - This function allows you to keep the display permanent on or turn it off two minutes after last pressing any button on the control panel.

Contrast - Use this function to adjust contrast of the display (0-100%).

Backlight - Use this function to adjust backlight of the display (0-100%).

Fans - Fans setting. Use the menu to set behaviour of fixture fans.

FansMode - the menu allows you to select desired power of fans:

Auto - Auto-control mode

Quiet - If the option is selected, power of fans can be set in the menu "Noise L."

BLC Fans - The menu item allows you to stop all fans in the fixture (option "On") when its light output is closed (shutter in range of 0-31 DMX or dimmer in 0 DMX).

Noise L. - The menu item allows you to set speed of fans. At low speed of fans the light output may be reduced.

Tungsten - Tungsten effect. This function simulates behaviour of a halogen lamp during dimming at calibrated whites 2700K-4200K. You can select from various lamp wattage simulation:

750W

1000W

1200W

2000W

2500W

Col. Mix - Colour mixing mode. This menu item allows selection between RGB and CMY mode. In 3-colour controlling modes (Mode 1, Mode 2,) all internal 5 colours are always utilized where possible.

Col. Cal. - Colour Calibration Mode. The function switches on/off an internal control of colours. For a standard operation of the fixture the option should be switched on. Option off has to be set during colour calibration of the fixture.

Dimmer C - Dimmer curve. Use the menu to select desired dimmer curve.

Line - a linear curve.

Sqrl - a square law curve.

SuSql - a super square law curve.

Opt Br. - Optic Brake - If the function is switched to the option On, the zoom will be blocked and will not respond to DMX values. After switching the fixture off and on, the zoom will stay in the original positions (position at moment of activation the brake).

Li. O S - Light output stability. If the function is on, the light output from the fixture is immediately reduced to a value corresponding to a thermal drop of the light intensity from the LED engine (the thermal drop - decreasing of the light intensity on 90 % of a starting level after first 5 minutes, then is the thermal drop inconsiderable).

Chro. W. - Chromatic White. If this function is on, the CTC channel influences colours and calibrated white colours. If this function is off, the CTC channel influences calibrated whites only.

O. Uni. - Light output uniformity. If the function is on, the light intensity from the fixture is corrected in order to get approximately the same light intensity as from another fixture which has also the function on. Thanks to the function, light outputs from more fixtures will have approximately the same light intensity.

LED Freq - LEDs frequency setup. The function allows you to set the PWM (Pulse Width Modulation) output frequency of LEDs. You can select from the following values:

300 Hz
600 Hz
1200 Hz
2400 Hz
High

LED F.adj - LEDs frequency fine adjustment. The function allows you to change the selected PWM output frequency of LEDs in 1266 levels up and down around the selected frequency in the menu "LED Freq".

-126...-001 - Frequency levels 1-126 under selected frequency.

000 - Selected frequency

001...126 - Frequency levels 1-126 above selected frequency.

Temp Uni - Temperature unit. Use the menu item to change temperature unit from °C to °F.

I Ef Pos - Init effect positions. Use the menu to set all effects to the desired positions at which they will stay after switching the fixture on without DMX signal. Confirm setting by the item "Store".

User Col. - Use this menu to show user colours saved in the fixture.

View Col. - The item allows you to read DMX values of colour channels for each user colour (1-10).

Dist. Col. - The item allows you to "send" user colours from this fixture to all connected T15 fixtures by means of RDM protocol. User colours in the fixtures will be overwritten.

Reset WPas. - Rest Web password. The menu item allows you to reset a password for access to the REAP (default password: 2479, user: robe).

Defaults - The menu item allows to set all fixture parameters to the default (factory) values.

7.3.4 Manual Control (Manual)

Use the menu to control all fixture channels by means of control buttons.

7.3.5 Test program (Test Prg)

Use this menu to run a special demo-test sequences without an external controller, which will show you some possibilities of using ROBIN T15.

7.3.6 Stand-alone (St Alone)

Auto Run - Presetting playback. This function allows you to select the program which will be played in the stand-alone mode after switching the fixture on. Selected program will be played continuously in a loop.

Off - The option disables „Auto Run” function.

Test - The option will start built-in test program.

Prog 1 - The option will start user-created program 1

Prog 2 - The option will start user-created program 2

Prog 3 - The option will start user-created program 3

Pr Play - Playing program. Select this menu to run a user-created program in a loop.

Test Prg - The option runs built-in test program.

Prog 1 - The option runs user-created program 1

Prog 2 - The option runs user-created program 2

Prog 3 - The option runs user-created program 3

Select the program you wish and press [ENTER]. The selected program starts running. By Pressing [ENTER] again, program pauses its running.

Pr Edit - Editing program. Select this menu to edit or create the program. The ROBIN T15 has one built-in program and one user-editable program up to 40 steps. Each program step has a step time - during which effects last in the current step and a fade time- during which effects move to new positions.

To edit program:

Procedure:

1. Press [NEXT] or [PREV] to select the menu "Edit" and press [ENTER].
2. Press [NEXT] or [PREV] to select the desired program step and press [ENTER] button.
3. Press [NEXT] or [PREV] to select the desired item and press [ENTER] button. Now you can edit by [NEXT] or [PREV] buttons the DMX value (0-255) for selected item:

Prg En.	a total number of the program steps (value 1-40). This value you should be set before starting of programming (e.g. if you want to create program with the 10 steps, set Prg En=10).
Powr	power/special functions
L Fre	a LED frequency selection
L Fr S	a LED frequency fine adjusting
Col F	colour functions
CRI S	a CRI selection
Virt C	a virtual colour wheel
Red	a red colour coarse
Red F	red colour fine
Green	a green colour coarse
Green F	green colour fine
Blue	a blue colour coarse
Blue F	blue colour fine
Amb	an amber colour
Amb F	an amber colour fine
Lime	a lime green
Lime F	lime green fine
CTC	a colour temperature correction
Gre C	a green correction
C Mix C	a colour mix control
Zoom	a zoom coarse
Zoom F	zoom fine
Stro	a strobe/shutter function
Dimm	a dimmer function coarse
Dim F	a dimmer function fine
F.Tim	a fade time (0-25.5 sec)
S.Tim	a step time (0-25.5 sec)
COPY	copy the current prog. step to the next prog. step

4. Press [ENTER] button to confirm adjusted value .
5. Press [ESCAPE] button, select next prog. step, press [ENTER] button and repeat steps 3 - 5).

7.3.7 Reset

This option enables you to reset mechanical zoom of the fixture.

7.3.8 Special functions (Special)

RDM Low - This menu item shows the first part of the RDM identification code.

RDM High - This menu item shows the second part of the RDM identification code.

Wireless - Wireless DMX information. The menu allows you to read some information about Wireless DMX operation (if wireless DMX/RDM module is connected)

Stat - Wireless status. Use the menu to read wireless DMX status.

Unlink - use the item to unlink the fixture from wireless DMX transmitter .

Adjust - Adjustment. The menu allows the fine adjustment of effects.

DMX Val- DMX values. Use the menu to set DMX values of fixture's channels.

Calib - calibration of the fixture.

Cal Mech - Use this menu to calibrate zoom position.

Calibration of the zoom module position via the control board

1. Disconnect DMX controller from the fixture and enter the "Cal Mech" menu.
2. Use the [PREV] and [NEXT] to find "Zoom C" and press [ENTER].
3. Set desired value and save it by pressing [ENTER].
4. After calibrating zoom, find item "Store" and press [ENTER]. to save adjusted value and reset the fixture.

Calibration protocol:

Effect	Mode 1	Mode 2	Mode 3	Mode 4	Mode 5	Mode 6
Zoom	channel 21	channel 11	channel 25	channel 8	channel 3	channel 2

Cal Col - The menu items "Red C", "Gre C", "Blu C", "Amb C" and "LiG C" serve for calibration of colours in the factory. User should not change settings in this menu.

The menu "Green Corr" serves for calibration of whites at standard CRI (80) (2700K I, 3200K I, 4200K I, 5600K I, 8000K I) and at high CRI (90+) (2700K C, 3200K C, 4200K C, 5600K C, 8000K C).

LEDs Cur - Calibration of LED currents. This process waits about 5 minutes and after its finishing the sign "CurC DONE" will appear on the display.

Cal Load - Loads default (factory) calibration.

Sw Upd - Software update. The menu item allows you to update software in the fixture via either serial or USB port of PC.

The following items are required in order to update software:

- PC running Windows or Linux or macOS
- DSU file
- Flash cable RS232/DMX, P/N13050624 (if you want to use a serial port of PC)
- Robe Universal Interface or Robe Universal interface WTX (if you want to use an USB port of PC)

After the software updating the fixture will be set to default values.

To update software in the fixture:

1. DSU file is available from Robe web site at WWW.robe.cz.
File with extension zip is intended for Windows (used and tested from XP to W10 on 32/64bit systems).
File with extension tbz is intended for Linux (used and tested on Debian and Ubuntu 32/64bit).
File with extension dmg is intended for macOS (used and tested on OSX up to Sierra) XQuartz required, install it from <https://www.xquartz.org/>
Save the download file to a folder on your computer.
In case that you use windows, extract files in the zip file (e.g. DSU_RobinT15_18100828.zip)
2. Disconnect the fixture from DMX controller.
3. If you use the flash cable RS232/DMX, connect a serial port of your computer with DMX input of the fixture by means of the cable.
If you use the Robe Universal Interface, connect a USB port of your computer with the Robe Universal Interface by means of the USB cable and DMX input of the fixture with the DMX output of the Robe Universal Interface via a DMX cable.
4. Switch the fixture to the update mode (tab "Service" --> Update Software).
Note: If you do not want to continue in the software update, you have to switch off and on the fixture to escape from the updating mode.
We recommend to cancel all running programs on your computer before starting the software update.
5. Double-click the software uploader file (e.g. DSU_RobinT15_18100828.exe) in the extracted files. The Software Uploader program will start to run.

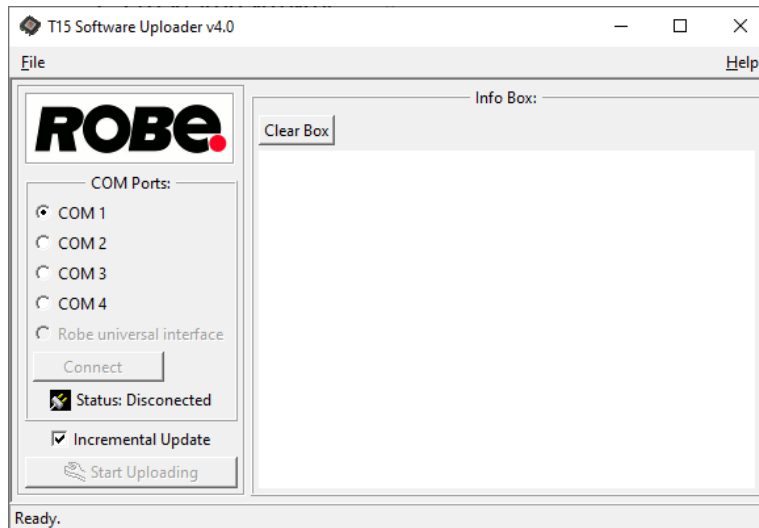

6. Select correct "COM " number if you use a Flash cable RS232/DMX or select "Robe Universal Interface " if you use the Robe Universal Interface/Robe Universal Interface WTX and then click on the "Connect" button.
7. If the connection is OK, click the "Start Uploading" button to start software uploading. It will take several minutes to perform software update.
 If the option "Incremental Update" is not checked, all processors will be updated (including processors with the same software version).
 If you wish to update only processors with new version of software, check the "Incremental Update box".
 Avoid interrupting the process. Update status is being displayed in the "Info Box" window.
 When the update is finished, the line with the text "Fixture is successfully updated" will appear in this window.
 In case upload process is interrupted (e.g. power loss), the fixture stays in "Updating mode" and you will have to repeat the software update again.

Another way, how to update software in the fixtures (especially large installation of fixtures) is to use the ROBE Uploader. It is a software for automatized software update of Robe fixtures. It takes advantage of RDM support).
 For more information please see <https://www.robe.cz/robe-uploader/>.

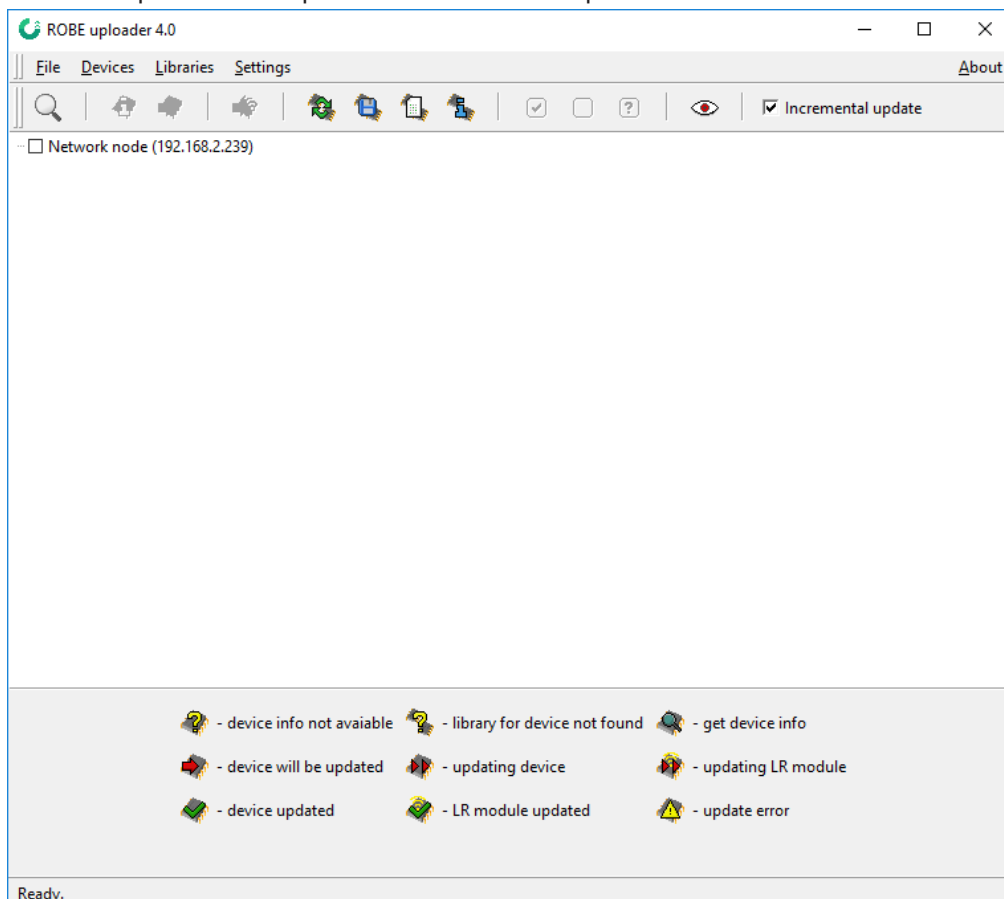

8. RDM

This fixture supports RDM operation. RDM (Remote Device Management) is a bi-directional communications protocol for use in DMX512 control systems, it is the new open standard for DMX512 device configuration and status monitoring.

The RDM protocol allows data packets to be inserted into a DMX512 data stream without adversely affecting existing non-RDM equipment. By using a special „Start Code,“ and by complying with the timing specifications for DMX512, the RDM protocol allows a console or dedicated RDM controller to send commands to and receive messages from specific moving lights.

RDM allows explicit commands to be sent to a device and responses to be received from it.

The list of commands for Robin T15 is the following.

Parameter ID	Discovery command	SET command	GET command
DISC_UNIQUE_BRANCH	*		
DISC_MUTE	*		
DISC_UN_MUTE	*		
DEVICE_INFO			*
SUPPORTED_PARAMETERS			*
SOFTWARE_VERSION_LABEL			*
DMX_START_ADDRESS		*	*
IDENTIFY_DEVICE		*	*
DEVICE_MODEL_DESCRIPTION			*
MANUFACTURER_LABEL			*
DEVICE_LABEL		*	*
SENSOR_DEFINITION			*
SENSOR_VALUE			*
DISPLAY_INVERT		*	*
DISPLAY_LEVEL		*	*
DEVICE_RESET		*	
DMX_PERSONALITY		*	*
DMX_PERSONALITY_DESCRIPTION			*
STATUS_MESSAGES			*
STATUS_ID_DESCRIPTION			*

RDM model ID for the Robin T15 is 0x0141.

9. Robe Ethernet Access Portal (REAP)

The REAP allows you to display on your computer information about some fixture settings, operating conditions (e.g. temperature in the fixture) and error messages which were generated during fixture operation. Your computer needs to be connected to the fixture(s) through the means of Ethernet wired network and a network switch.

The Ethernet network connection (Local LAN) typically needs to be set to 2.x.x.x address, assuming that no other computer on the network contains such an address while keeping all ROBE fixtures in default IP settings.

For more information about REAP options, computer and fixture settings please see the REAP user manual at https://www.robe.cz/res/downloads/user_manuals/User_manual_REAP.pdf.

10. Error and information messages

Zoom Err

This message will appear after reset of the fixture if the zoom module is not located in the default position. Cause of the message can be some defective zoom stepping motor.

Red Shrt

The message informs you that short circuit has occurred in the red LEDs circuit on the LEDs PCB.

Green Shrt

The message informs you that short circuit has occurred in the green LEDs circuit on the LEDs PCB.

Blue Shrt

The message informs you that short circuit has occurred in the blue LEDs circuit on the LEDs PCB.

Amber Shrt

The message informs you that short circuit has occurred in the amber LEDs circuit on the LEDs PCB.

Lime Shrt

The message informs you that short circuit has occurred in the lime LEDs circuit on the LEDs PCB.

Red Unp

The message informs you that red LEDs circuit has been interrupted on the LEDs PCB.

Green Unp

The message informs you that green LEDs circuit has been interrupted on the LEDs PCB.

Blue Unp

The message informs you that blue LEDs circuit has been interrupted on the LEDs PCB.

Amber Unp

The message informs you that amber LEDs circuit has been interrupted on the LEDs PCB.

Lime Unp

The message informs you that lime LEDs circuit has been interrupted on the LEDs PCB.

11. Technical Specifications

Electrical

Power supply: electronic auto-ranging
Input voltage range: 100-240V, 50-60Hz
Fuse: T 6.3 A, 250V
Max. power consumption: 440W (power factor 0.98)
Mains input: - max. 16A (US 13A)
Mains output: - max. 12A (US 9A)

Optic

Light source: MSL-TE™ 350W LED engine
CMY/RGB colour mixing
CRI: Adjustable from 80 to 90+
Typical lumen maintenance: L70/B50 @ 40.000 hours

Virtual colour wheel

67 preset colours
10 user colours
Rainbow effect with variable speed

Colour temperature functions

White light: Variable CTC 2700K – 8000K
Tungsten lamp effect at whites 2700K- 4200K

Zoom

Motorized zoom
Beam angle: 10° - 72°(Fresnel lens)
Beam angle: 10° - 72°(PC lens)

Strobe

Strobe effect with variable speed (0.3 - 20Hz)

Dimmer

Smooth dimmer from 0 - 100 %

Control

Setting & Addressing: two-row LCD display & 4 buttons, 4 control knobs
Readout fixture and LEDs usage, receiving DMX values, temperatures, etc
Built-in analyzer for easy fault finding, error messages
Built-in demo sequences
Silent fans cooling,
Stand-alone operation
3 user editable programs, each up to 40 steps
Supported protocols: USITT DMX 512, RDM, ArtNet, MANet, MANet2, sACN
Support of RDM (Remote Device Management)
6 DMX modes (20, 10, 24, 7, 2, 1 control channels)

External wireless DMX/RDM module RW 001 (optional)

Supported protocols: full RDM support, CRMX , W-DMX™ G2, G3,G4 and G4S
Operational frequency range: 2402-2480 MHz
Output power: 100 mW
Receiver sensitivity (0.1% BER): -93 dBm
Crystal Clock Frequency : 16.0 MHz
Contains FCC ID: 2A6PL-DMXRDMRW001
Contains IC: 29573-DMXRDMRW001

Connection

DMX data IN/OUT: 2x Locking 5-pin XLR
AC power IN/OUT: 2x Neutrik PowerCon TRUE 1
Ethernet: 1x RJ45
Ethernet IN/OUT (EP version only): 2 x RJ 45

Max. number of fixtures in Ethernet IN/Out line (EP version only)

8

Rigging

Via mounting bracket (97° tilt range)

Temperatures

Maximum/Minimum ambient operating temperature : +45°C/-5°C
Maximum housing temperature : 70° C

Minimum distances

Min. distance from flammable surfaces: 0.5 m
Min. distance to lighted object: 2 m

Total heat dissipation

1125 BTU/hr (calculated)

Protection factor

IP20 (CE)
Dry locations only (US)

Weight

T15 Fresnel: 12 kg (26.45 lbs)
T15 PC: 14.5 kg (31.9 lbs)

Dimensions (mm)

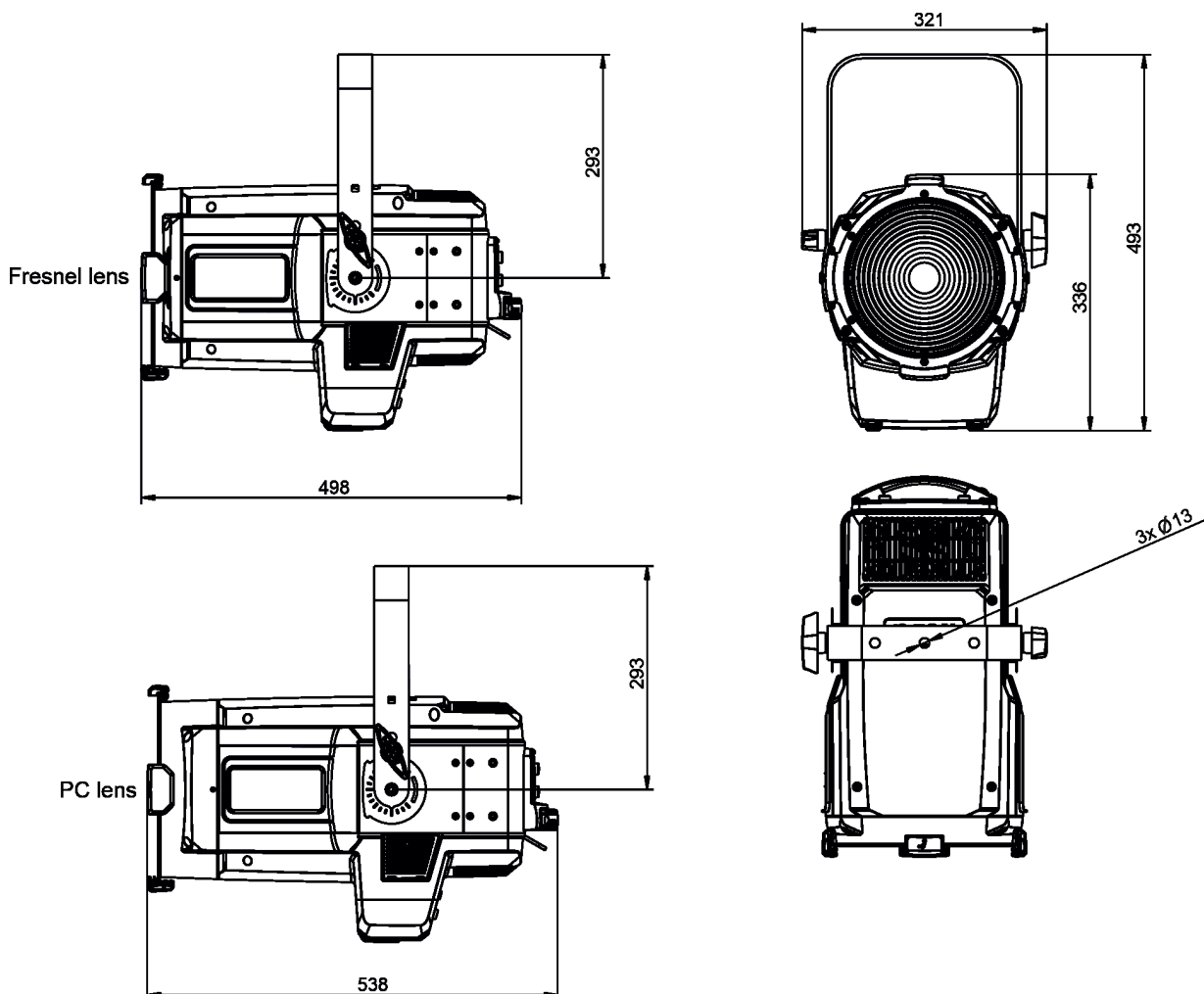

Accessories

- 1x user manual
- 1 x gel frame adaptor (installed on the fixture)

Optional accessories

- T11/T15 TE™ 350W Multi-Spectral LED Engine (P/N 14080070)
- T11/T15 TE™ 350W TGW White LED Engine (P/N 14080090)
- T11/T15 TE™ 350W DL White LED Engine (P/N 14080089)
- Doughty Trigger Clamp (P/N 17030386)
- Wireless DMX external module (P/N 10980127)
- Safety wire 36 kg (P/N 99011963)
- T15 PC lens module (P/N 10981023)
- T11/T15 Incline Adaptor (P/N 10980853)
- Gel Frame T15 (P/N 10981027)
- Pole operated yoke (P/N 10980667)
- 4-leaf Barndoor module (P/N 10981010)
- 8-leaf Barndoor module (P/N 10981011)
- Floor stand (P/N 10981014)
- Mains Cable powerCON TRUE1 In/Schuko, 2m, Indoor (P/N 13052405)
- Mains Cable powerCON TRUE1 In/US, 2m, Indoor (P/N 13052406)
- Daisy Chain powerCON TRUE1 In/Out, EU, 2m, Indoor (P/N 13052439)
- Mains Cable powerCON TRUE1 In/CEE 16A, 2m, Indoor (P/N 13052445)
- Mains Cable powerCON TRUE1 In/Open ended, 2m, Indoor (P/N 13052407)
- Daisy Chain powerCON TRUE1 In/Out, US, 2m, Indoor (P/N 13052440)
- Daisy Chain powerCON TRUE1 In/Out, EU, 5m, Indoor (P/N 13052444)

12. Maintenance and cleaning

It is absolutely essential that the fixture is kept clean and that dust, dirt and smoke-fluid residues must not build up on or within the fixture. Otherwise, the fixture's light-output will be significantly reduced. Regular cleaning will not only ensure the maximum light-output, but will also allow the fixture to function reliably throughout its life. A soft lint-free cloth moistened with any good glass cleaning fluid is recommended, under no circumstances should alcohol or solvents be used!

DANGER !
***Disconnect from the mains before starting any
maintenance or cleaning work.***

The front lens will require weekly cleaning as smoke-fluid tends to building up residues, reducing the light output very quickly. The cooling fans should be cleaned monthly. The interior of the fixture should be cleaned at least annually using a vacuum-cleaner or an air-jet. Internal lenses should be cleaned monthly.

Replacing the fuse.

Before replacing the fuse, unplug mains lead.

1. Remove the fuse holder on the rear panel of the fixture with a fitting screwdriver from the housing (anti-clockwise).
2. Remove the blown fuse from the fuse holder.
3. Install the new fuse in the fuse holder (only the same type and rating).
4. Replace the fuse holder in the housing and fix it.

Checking plastic parts of the fixture.

The plastic parts of the fixture should be checked for damages and beginning cracks at least every two months. In addition, the plastic part of the front lens has to be checked mechanically (by means of movement by the plastic part) if it is firmly fastened to the fixture. If hint of a crack is found on some plastic part, do not use the fixture until the damaged part will be replaced.

Cracks or another damages of the plastic parts can be caused by the fixture transportation or manipulation and also ageing process may influence plastic materials.

This checking is necessary for both fixed installations and preparing fixtures for renting. Any free moving parts inside of the fixture head, cracked plastic or any plastic part of front lens not sitting properly in place need to be immediately replaced.

12.1 Disposing of the product

To preserve the environment please dispose or recycle this product at the end of its life according to the local regulations and codes.

13. ChangeLog

This section summarizes changes in the user manual.

Version of the manual	Date of issue	Description of changes
1.1	15/08/2024	Menu Personal changed
1.2	08/10/2024	Pole operated yoke installation added

October 8, 2024

Copyright © 2024 Robe Lighting - All rights reserved

All Specifications subject to change without notice

Made in CZECH REPUBLIC by ROBE LIGHTING s.r.o. Palackeho 416/20 CZ 75701 Valasske Mezirici



14. Appendix

14.1 Changing the LED light source

The Robin T15 allows you to change the LED light source and this way keep a high performance of the fixture. The LED light source replacement is done in the same way as at T11 fixture.

1. Disconnect the fixture from mains and allow it to cool about 30 minutes.
2. Remove top cover of the fixture and place the fixture a horizontal position in which you will have access to the rear panel with display.

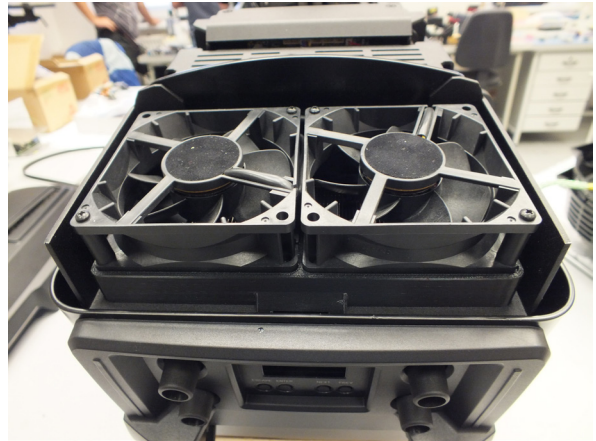

3. Unscrew two screws M4x12 with star washers (1) on both sides the fixture.

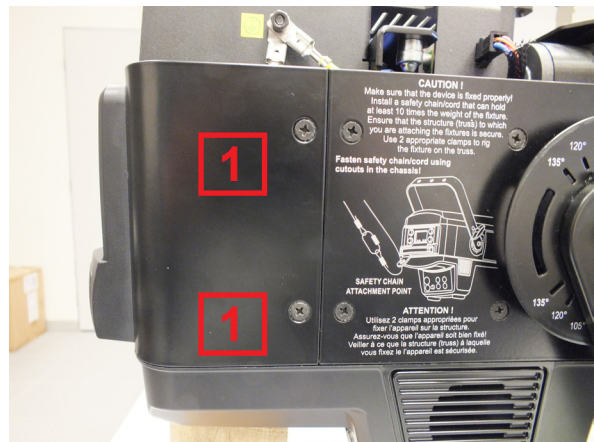

4. Slide the rear cover (2) with display out of the fixture and put it next to the fixture on elevated place. You do not need to disconnect cables.

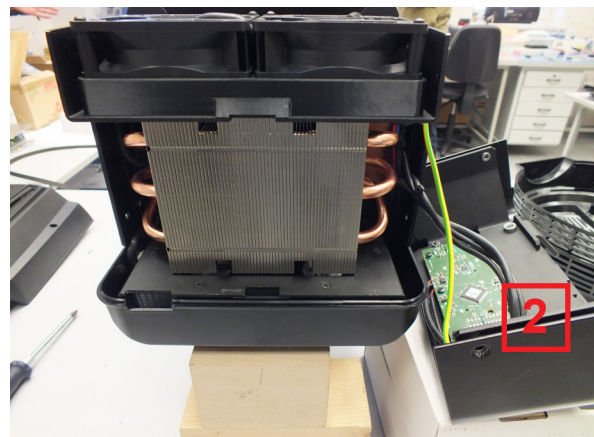

5. Unscrew the four socket head screws M4x16 (3) with plain washers (use Allen key 3) and carefully slide the LED source module (4) out from the fixture. Be careful, do not to damage connectors on LEDs PCB!

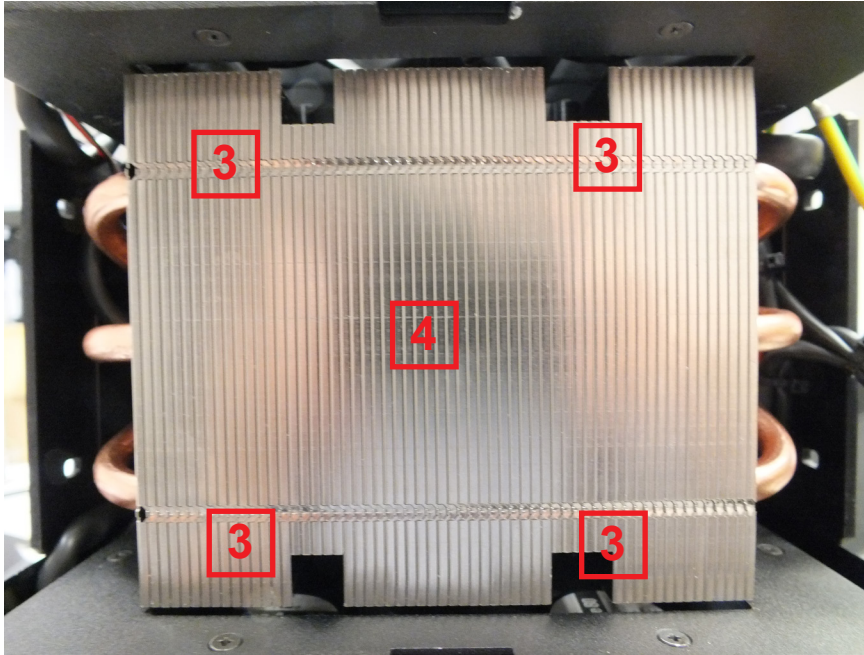

6. Disconnect the cable (5) from black connector on the left side of the fixture.

7. Disconnect two cables (6) from black connector and from white connector on the right side of the fixture.

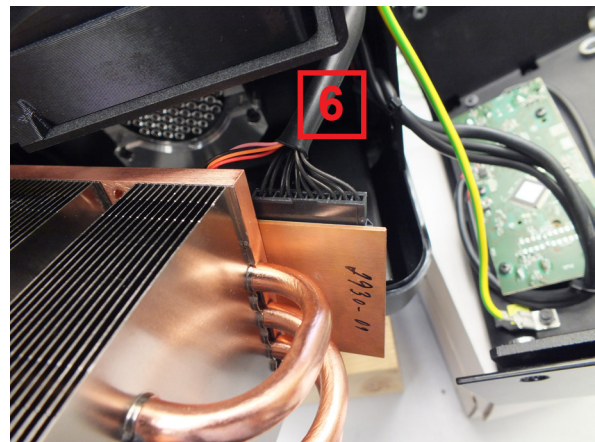
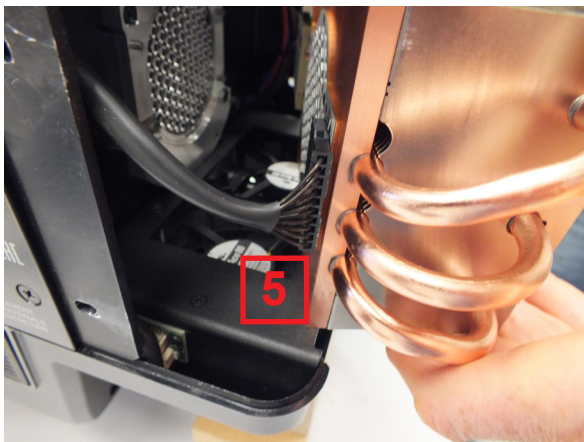

8. Remove the LED light source (4) from the fixture.

The LED light source includes PCB with LEDs and the heat sink. Handle with care. Do not touch LEDs with bare hands.

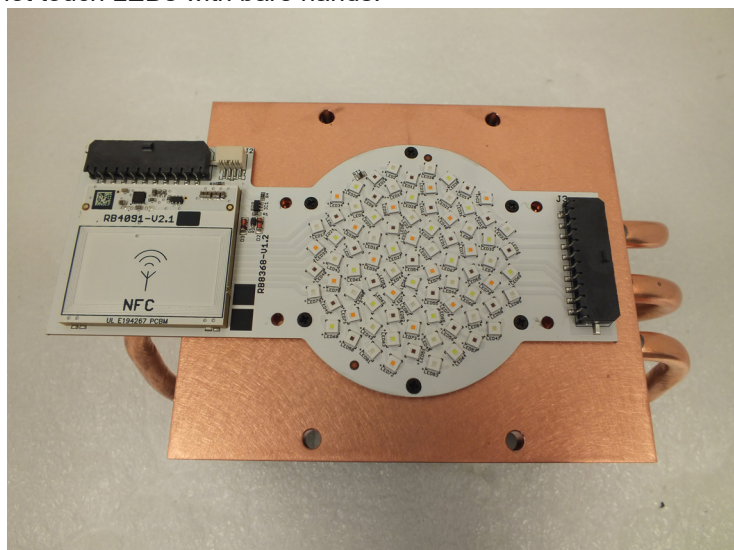

9. Connect two cables (6) to the black and white connectors on the right side of the new LED module.
Connect one cable (5) to the black connector on the left side of the new LED module.

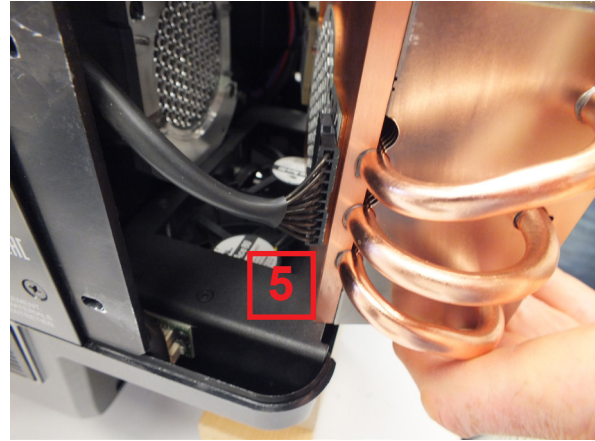
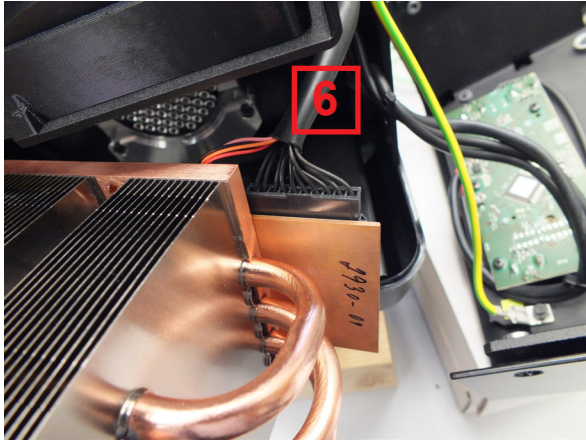

10. Insert the new LED source module (4) to the fixture and screw it by means of four screws M4x16 (3) to the fixture.

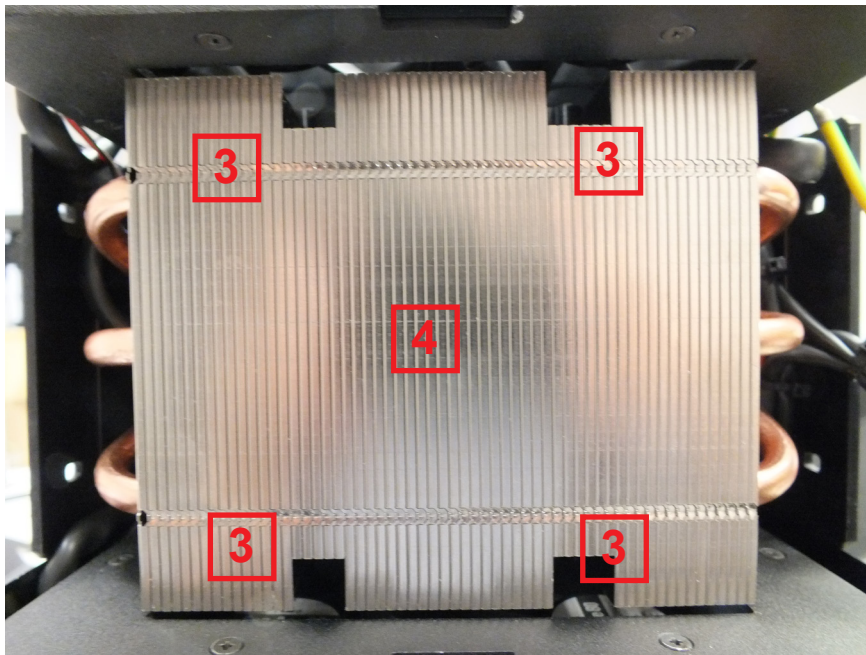

11. Insert the rear cover (2) with display to the fixture.

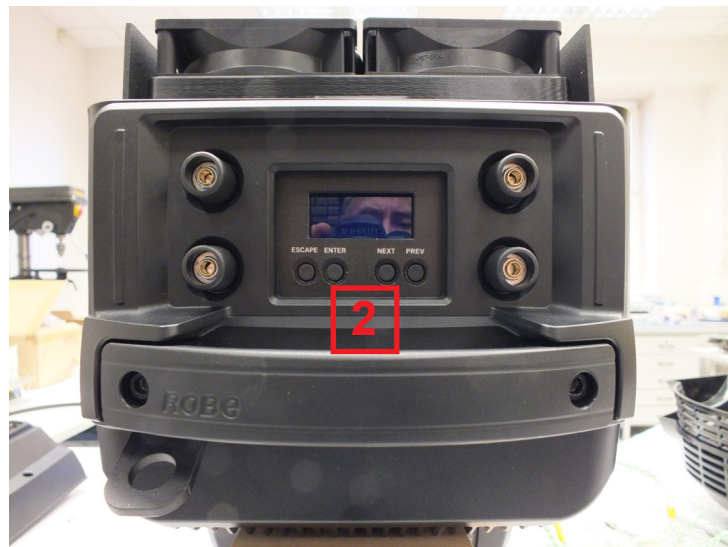

12. Check the rear cover does not cut wires under the cover.

Right side of the fixture

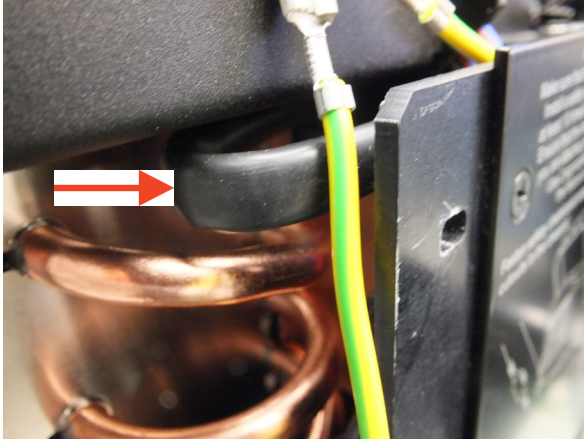

Left side of the fixture

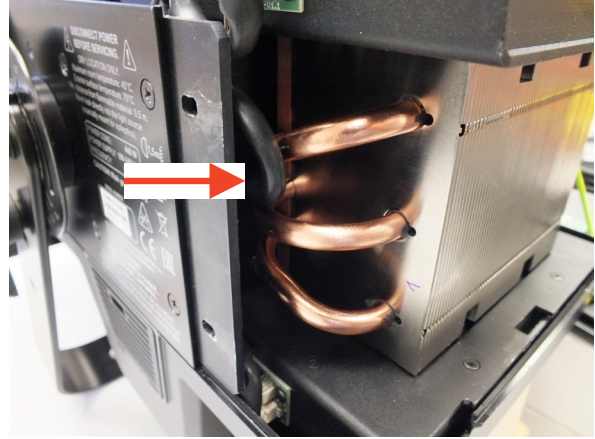

Right side of the fixture

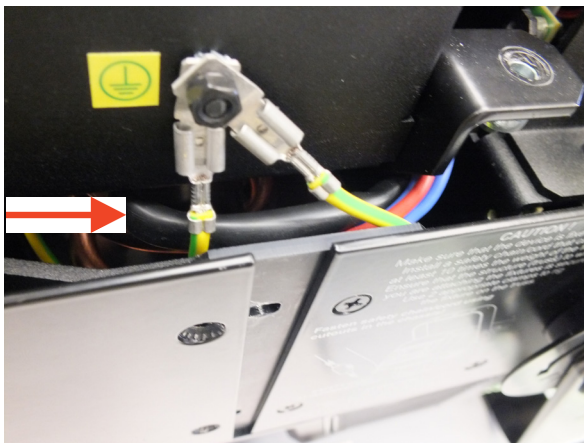

Left side of the fixture



Top side of the fixture

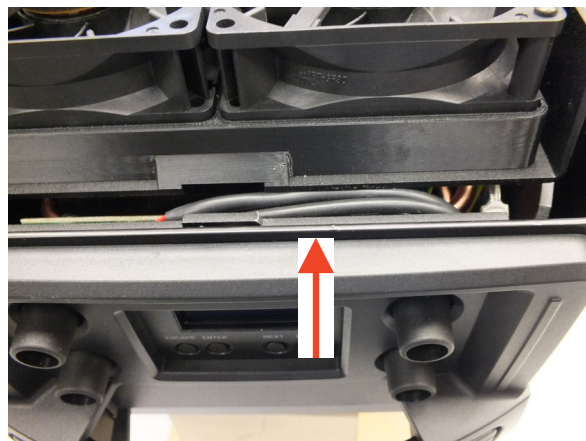

13. Screw the rear cover (2) back to the fixture by means of the two screws M4x12 on each side of the fixture.
14. Fasten the top cover on the fixture.

14.2 Obtaining information about the LED light source by mobile phone

You can read information about the LED light source by means of the mobile application ROBE COM. The LED light source has to be outside of the fixture.

Download and install the application ROBE COM from Google Play (for Android 5.0 and higher) or App Store (for iOS 12.0 and higher) to your mobile phone. Your mobile phone has to support NFC (Near-Field Communication).

After installing the ROBE COM, run the application by touching the icon  .
The following screen will appear:

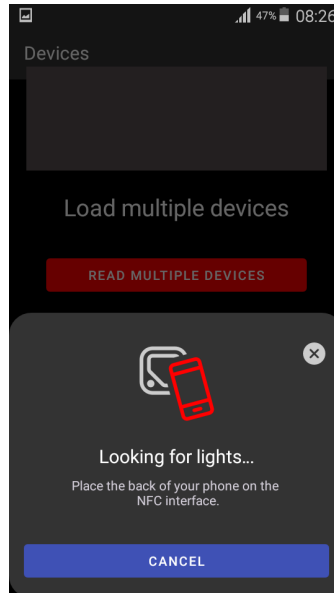

Hold the mobile phone close to the point of the LED light source PCB which is marked with the symbol NFC.

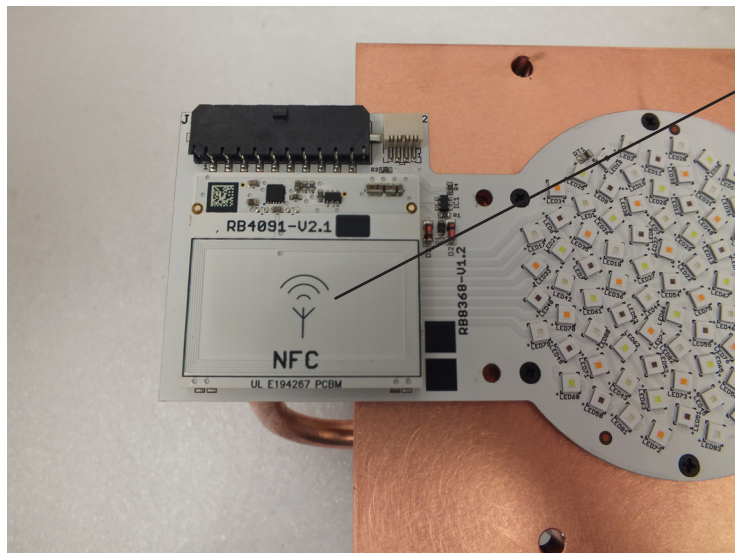

If NFC connection is OK, the following screens will appear.

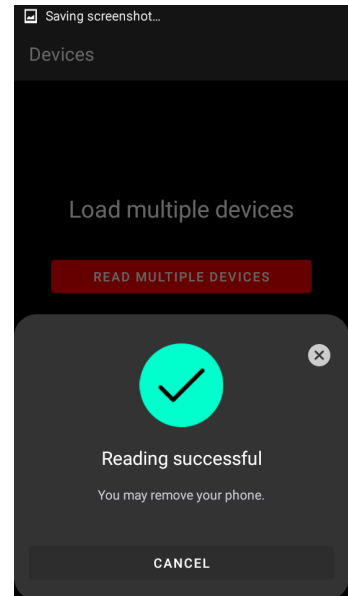
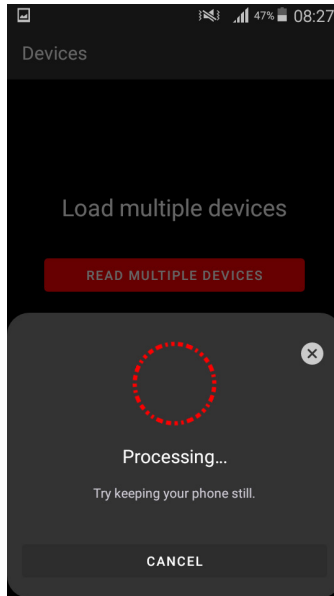
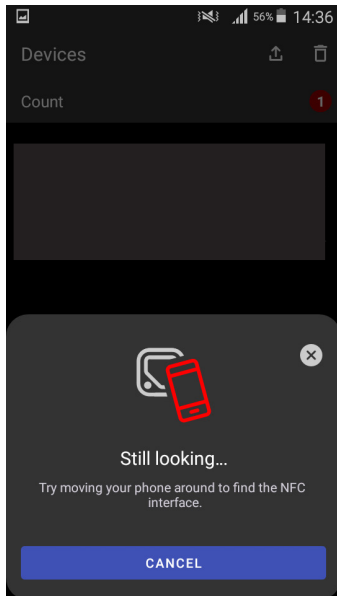

When the following screen will appear, touch the button CANCEL.

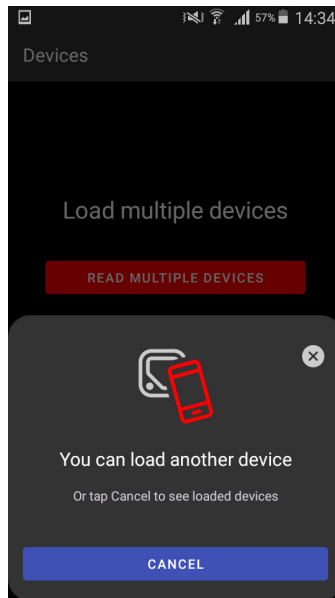

Touch the found LED module ("Robin T11 LED module") and then touch "LED engine" to read information about found LED module.

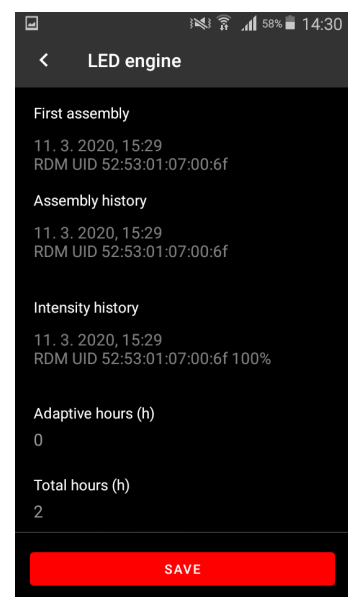
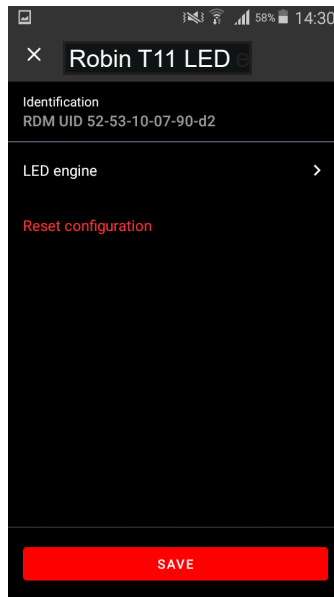
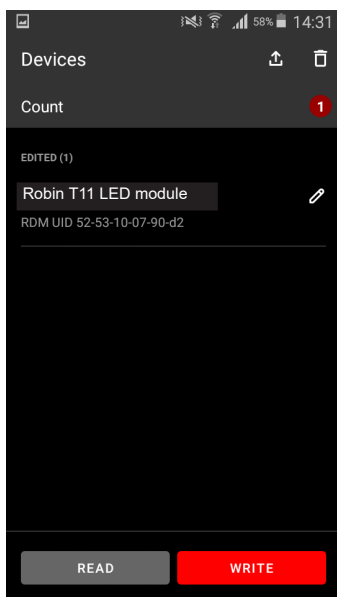

Robin T15™ Fresnel/PC - DMX protocol							
Version: 1.0							
Short description of modes							
Mode	Description						
1	16-bit CMY/RGB, 20 channels in total						
2	8-bit CMY/RGB, 10 channels in total						
3	16-bit RGBAL, 24 channels in total						
4	White light+zoom & dimmer , 7 channels in total						
5	Zoom & Dimmer , 2 channels in total						
6	Only Dimmer, 1 channel in total						
Quick overview of default DMX values for each channel							
Mode/channel						Default DMX Value	Function
1	2	3	4	5	6		
1	1	1	*	*	*	0	Power/Special functions
2	*	2	*	*	*	10	LED frequency selection
3	*	3	*	*	*	128	LED frequency fine adjusting
4	2	4	*	*	*	0	Colour functions
5	3	5	1	*	*	0	CRI selection
6	*	6	*	*	*	0	Virtual colour wheel
7	4	*	*	*	*	0/255	Cyan/Red (8 bit) (0=default for CMY mode, 255=default for RGB mode)
8	*	*	*	*	*	0/255	Cyan/Red (16 bit) (0=default for CMY mode, 255=default for RGB mode)
9	5	*	*	*	*	0/255	Magenta/Green (8 bit) (0=default for CMY mode, 255=default for RGB mode)
10	*	*	*	*	*	0/255	Magenta/Green (16 bit) (0=default for CMY mode, 255=default for RGB mode)
11	6	*	*	*	*	0/255	Yellow/Blue (8 bit) (0=default for CMY mode, 255=default for RGB mode)
12	*	*	*	*	*	0/255	Yellow/Blue (16 bit) (0=default for CMY mode, 255=default for RGB mode)
*	*	7	*	*	*	255	Red (8 bit)
*	*	8	*	*	*	255	Red (16bit)
*	*	9	*	*	*	255	Green (8 bit)
*	*	10	*	*	*	255	Green (16bit)
*	*	11	*	*	*	255	Blue (8 bit)
*	*	12	*	*	*	255	Blue (16bit)
*	*	13	*	*	*	255	Amber (8 bit)
*	*	14	*	*	*	255	Amber (16bit)
*	*	15	*	*	*	255	Lime (8 bit)
*	*	16	*	*	*	255	Lime (16bit)
13	7	17	2	*	*	110	Colour temperature correction (CTC)
14	*	18	3	*	*	128	Green correction
15	*	19	*	*	*	0	Colour mix control
16	8	20	4	1	*	128	Zoom (8-bit)
17	*	21	5	*	*	0	Zoom (16-bit)
18	9	22	*	*	*	32	Shutter/ strobe
19	10	23	6	2	1	0	Dimmer intensity (8-bit)
20	*	24	7	*	*	0	Dimmer intensity (16-bit)

DMX protocol

Mode/channel						DMX Value	Function	Type of control
1	2	3	4	5	6			
1	1	1	*	*	*		Power/Special functions	
						0 -19	Reserved (0=default) <i>To activate following functions, stop in DMX value for at least 3 s and shutter must be closed at least 3 sec. („Shutter,Strobe“ channel 18/9/22 must be at range: 0-31 DMX). Corresponding menu items are temporarily overridden.</i>	
						20-24	Display: On	step
						25-29	Display: Off	step
						30-69	Reserved	
						70-74	Fans mode: Auto	step
						75-79	Reserved	
						80-84	Quiet mode: Fans On at blackout	step
						85-89	Quiet mode: Fans Off at blackout	step
						90-129	Reserved <i>To activate following functions, stop in DMX value for at least 3 seconds.</i>	
						130-134	Simple mode off	step
						135-159	Zoom reset	step
						160-235	Reserved	
						236-237	Optics brake On	step
						238-239	Optics brake Off	step
						240	Disabled "Quiet mode"	step
						241-255	Quiet mode - fan noise control from min. to max.	proportional
2	*	2	*	*	*		LED frequency selection	
							Factory display menu setting: 600Hz <i>Select PWM output frequency of LEDs. Selected PWM frequency can be fine adjusted in 127 steps up/down around selected PWM frequency on the channel below. Corresponding menu item (Frequency Setup) is temporarily overridden.</i>	
						0-4	PWM frequency from Display menu (fixture utilizes PWM frequency set in the display menu item Frequency Setup).	step
						5-9	300 Hz	step
						10-14	600 Hz (10=default)	step
						15-19	1200 Hz	step
						20-24	2400 Hz	step
						25-29	High	step
						30-255	Reserved (fixture utilizes PWM frequency set in the display menu item Frequency Setup).	
3	*	3	*	*	*		LED frequency fine adjusting	
							Factory display menu setting: 600Hz <i>Select desired PWM output frequency of LEDs on the channel above.</i>	
						0-1	Selected LED Frequency	step
						2	LED Frequency (step -126)	step
						3	LED Frequency (step -125)	step
						4	LED Frequency (step -124)	step
						:		
						125	LED Frequency (step -3)	step
						126	LED Frequency (step -2)	step

DMX protocol

Mode/channel						DMX Value	Function	Type of control
1	2	3	4	5	6			
						127	LED Frequency (step -1)	step
						128	Selected LED Frequency (128=default)	step
						129	LED Frequency (step +1)	step
						130	LED Frequency (step +2)	step
						131	LED Frequency (step +3)	step
						:		
						252	LED Frequency (step +124)	step
						253	LED Frequency (step +125)	step
						254	LED Frequency (step +126)	step
						255	Selected LED Frequency	step
4	2	4	*	*	*		Colour functions	
							Factory display menu setting: Colour mixing mode-CMY, Dimmer Curve-Square Law, Tungsten effect simulation-Off, Chromatic white-Off, Light output stability-Off, Uniformity-Off	
						0	No function (0=default) <i>To activate following functions, stop in DMX value for at least 3 seconds. Corresponding menu items are temporarily overridden</i>	step
						1-39	Reserved	
						40-44	Colour mixing mode: CMY (DMX Mode 1, 2 only)	step
						45-49	Colour mixing mode: RGB (DMX mode 1, 2 only), RGBAL (DMX mode 3 only)	step
						50-54	Dimmer curve: Square law	step
						55-59	Dimmer curve: Linear	step
						60-64	Dimmer curve: Super square law	step
						65-79	Raw DMX	proportional
							<i>Tungsten effect simulation for whites 2700K-4200K only:</i>	
						80-84	Tungsten effect simulation (750W/80V): On	step
						85-89	Tungsten effect simulation (1000W/240V): On	step
						90-94	Tungsten effect simulation (1200W/240V): On	step
						95-99	Tungsten effect simulation (2000W/230V): On	step
						100-104	Tungsten effect simulation (2500W/230V): On	step
						105-109	Tungsten effect simulation: Off	step
						110-114	Save user colour (see user manual)	step
						115-119	Chromatic white: On	step
						120-124	Chromatic white: Off	step
						125-129	Light output stability On	step
						130-134	Light output stability Off	step
						135-139	Uniformity On	step
						140-144	Uniformity Off	step
						145-255	Reserved	
5	3	5	1	*	*		CRI selection	
						0-255	CRI selection from Standard (80) to High (90+) (0=default)	proportional
6	*	6	*	*	*		Virtual colour wheel	
						0	No function (0=default)	step
						1-2	Filter 4 (Medium Bastard Amber)	step
						3-4	Filter 10 (Medium Yellow)	step
						5-6	Filter 19 (Fire)	step
						7-8	Filter 26 (Bright Red)	step
						9-10	Filter 58 (Lavender)	step
						11-12	Filter 68 (Sky Blue)	step

DMX protocol

Mode/channel						DMX Value	Function	Type of control
1	2	3	4	5	6			
						13-14	Filter 71 (Tokyo Blue)	step
						15-16	Filter 79 (Just Blue)	step
						17-18	Filter 88 (Lime Green)	step
						19-20	Filter 90 (Dark Yellow Green)	step
						21-22	Filter 100 (Spring Yellow)	step
						23-24	Filter 101 (Yellow)	step
						25-26	Filter 102 (Light Amber)	step
						27-28	Filter 103 (Straw)	step
						29-30	Filter 104 (Deep Amber)	step
						31-32	Filter 105 (Orange)	step
						33-34	Filter 106 (Primary Red)	step
						35-36	Filter 111 (Dark Pink)	step
						37-38	Filter 115 (Peacock Blue)	step
						39-40	Filter 116 (Medium Blue-Green)	step
						41-42	Filter 117 (Steel Blue)	step
						43-44	Filter 118 (Light Blue)	step
						45-46	Filter 119 (Dark Blue)	step
						47-48	Filter 120 (Deep Blue)	step
						49-50	Filter 121 (Filter Green)	step
						51-52	Filter 128 (Bright Pink)	step
						53-54	Filter 131 (Marine Blue)	step
						55-56	Filter 132 (Medium Blue)	step
						57-58	Filter 134 (Golden Amber)	step
						59-60	Filter 135 (Deep Golden Amber)	step
						61-62	Filter 136 (Pale Lavender)	step
						63-64	Filter 137 (Special Lavender)	step
						65-66	Filter 138 (Pale Green)	step
						67-68	Filter 139 (Primary Green)	step
						69-70	Filter 141 (Bright Blue)	step
						71-72	Filter 147 (Apricot)	step
						73-74	Filter 148 (Bright Rose)	step
						75-76	Filter 152 (Pale Gold)	step
						77-78	Filter 154 (Pale Rose)	step
						79-80	Filter 157 (Pink)	step
						81-82	Filter 158 (Deep Orange)	step
						83-84	Filter 162 (Bastard Amber)	step
						85-86	Filter 164 (Flame Red)	step
						87-88	Filter 165 (Daylight Blue)	step
						89-90	Filter 169 (Lilac Tint)	step
						91-92	Filter 170 (Deep Lavender)	step
						93-94	Filter 172 (Lagoon Blue)	step
						95-96	Filter 179 (Chrome Orange)	step
						97-98	Filter 180 (Dark Lavender)	step
						99-100	Filter 181 (Congo Blue)	step
						101-102	Filter 197 (Alice Blue)	step
						103-104	Filter 201 (Full C.T. Blue)	step
						105-106	Filter 202 (Half C.T. Blue)	step
						107-108	Filter 203 (Quarter C.T. Blue)	step

DMX protocol

Mode/channel						DMX Value	Function	Type of control
1	2	3	4	5	6			
						109-110	Filter 204 (Full C.T. Orange)	step
						111-112	Filter 205 (Half C.T. Orange)	step
						113-114	Filter 206 (Quarter C.T. Orange)	step
						115-116	Filter 247 (Filter Minus Green)	step
						117-118	Filter 248 (Half Minus Green)	step
						119-120	Filter 281 (Three Quarter C.T. Blue)	step
						121-122	Filter 285 (Three Quarter C.T. Orange)	step
						123-124	Filter 352 (Glacier Blue)	step
						125-126	Filter 353 (Lighter Blue)	step
						127-128	Filter 715 (Cabana Blue)	step
						129-130	Filter 778 (Millennium Gold)	step
						131-132	Filter 793 (Vanity Fair)	step
						133-215	Reserved	
						216-217	User colour 1	step
						218-219	User colour 2	step
						220-221	User colour 3	step
						222-223	User colour 4	step
						224-225	User colour 5	step
						226-227	User colour 6	step
						228-229	User colour 7	step
						230-231	User colour 8	step
						232-233	User colour 9	step
						234-235	User colour 10	step
						236-245	Rainbow effect (with fade time) from slow-> fast	proportional
						246-255	Rainbow effect (without fade time) from slow-> fast	proportional
7	4	*	*	*	*		Cyan/Red (8 bit)	
						0 - 255	Colour saturation control - coarse 0-100% (0=default for CMY mode, 255=default for RGB mode)	proportional
8	*	*	*	*	*		Cyan/Red (16 bit)	
						0 - 255	Colour saturation control - fine (0=default for CMY mode, 255=default for RGB mode)	proportional
9	5	*	*	*	*		Magenta/Green (8 bit)	
						0 - 255	Colour saturation control - coarse 0-100% (0=default for CMY mode, 255=default for RGB mode)	proportional
10	*	*	*	*	*		Magenta/Green (16 bit)	
						0 - 255	Colour saturation control - fine (0=default for CMY mode, 255=default for RGB mode)	proportional
11	6	*	*	*	*		Yellow/Blue (8 bit)	
						0 - 255	Colour saturation control - coarse 0-100% (0=default for CMY mode, 255=default for RGB mode)	proportional
12	*	*	*	*	*		Yellow/Blue (16 bit)	
						0 - 255	Colour saturation control - fine (0=default for CMY mode, 255=default for RGB mode)	proportional
*	*	7	*	*	*		Red (8 bit)	
						0 - 255	Colour saturation control - coarse 0-100% (255=default)	proportional
*	*	8	*	*	*		Red (16bit)	
						0 - 255	Colour saturation control - fine (255=default)	proportional
*		9	*	*	*		Green (8 bit)	
						0 - 255	Colour saturation control - coarse 0-100% (255=default)	proportional

DMX protocol

Mode/channel						DMX Value	Function	Type of control
1	2	3	4	5	6			
*		10	*	*	*	0 - 255	Green (16bit) Colour saturation control - fine (255=default)	proportional
*		11	*	*	*	0 - 255	Blue (8 bit) Colour saturation control - coarse 0-100% (255=default)	proportional
*		12	*	*	*	0 - 255	Blue (16bit) Colour saturation control - fine (255=default)	proportional
*		13	*	*	*	0 - 255	Amber (8 bit) Colour saturation control - coarse 0-100% (255=default)	proportional
*		14	*	*	*	0 - 255	Amber (16bit) Colour saturation control - fine (255=default)	proportional
*		15	*	*	*	0 - 255	Lime (8 bit) Colour saturation control - coarse 0-100% (255=default)	proportional
*		16	*	*	*	0 - 255	Lime (16bit) colour saturation control - fine (255=default)	proportional
13	7	17	2	*	*	0-1	CTC 8000 K	step
						2-64	Colour temperature changing 7978 K ->6622 K (22 K /1 DMX)	proportional
						65	6600 K	step
						66-109	Colour temperature changing 6578K ->5622 K (22 K/1 DMX)	proportional
						110	5600 K (110=default)	step
						111-179	Colour temperature changing 5580 K ->4220 K (20 K/1 DMX)	proportional
						180	4200 K	step
						181-229	Colour temperature changing 4180 K ->3220 K (20 K/1 DMX)	proportional
						230	3200 K	step
						231-254	Colour temperature changing 3180 K ->2720 K (20K /1 DMX)	proportional
						255	2700K	step
14	*	18	3	*	*	0	Green correction Uncorrected white	step
						1-127	Minus green --> uncorrected white	proportional
						128	Uncorrected white (128=default)	step
						129-255	Uncorrected white --> Plus green	proportional
15	*	19	*	*	*		Colour mix control <i>Defines relation between Virtual Colour wheel and colour channels</i> "Virtual" = Virtual Colour Wheel "Colour mix" = Colour channels (CMY/RGBAL/CTC)	
						0-9	"Virtual " has priority over "Colour mix" (0=default)	
						10-19	Maximum mode (highest values have priority)	step
						20-29	Minimum mode (lowest values have priority)	step
						30-39	Multiply mode (multiply "Virtual" and "Colour mix")	step
						40-49	Addition mode ("Virtual" + "Colour mix")	step
						50-59	Subtraction mode ("Virtual" - "Colour mix")	step
						60-69	Inverted Subtraction mode ("Colour mix"- "Virtual")	step
						70-79	White Point Off (CTC+Green Cor.+Virtual Colour Wheel deactivated)	step
						80-128	Reserved	
						129	Crossfade "Virtual" only	step
						130-254	Crossfade between "Virtual" and "Colour mix"	proportional
						255	Crossfade "Colour mix" only	step

DMX protocol

Mode/channel						DMX Value	Function	Type of control
1	2	3	4	5	6			
16	8	20	4	1	*		Zoom (8-bit)	
						0 - 255	Zoom from max. to min.beam angle (128=default)	proportional
17	*	21	5	*	*		Zoom (16-bit)	
						0-255	Fine zooming (0=default)	proportional
18	9	22	*	*	*		Shutter/ strobe	
						0 - 31	Shutter closed	step
						32 - 63	Shutter open (32=default)	step
						64 - 95	Strobe-effect from slow to fast	proportional
						96 - 127	Shutter open	step
						128 - 143	Opening pulse in sequences from slow to fast	proportional
						144 - 159	Closing pulse in sequences from fast to slow	proportional
						160 - 191	Shutter open	step
						192 - 223	Random strobe-effect from slow to fast	proportional
						224 - 255	Shutter open	step
19	10	23	6	2	1		Dimmer intensity (8-bit)	
						0 - 255	Dimmer intensity from 0% to 100% (0=default)	proportional
20	*	24	7	*	*		Dimmer intensity (16-bit)	
						0 - 255	Fine dimming (0=default)	proportional
Copyright © 2023 Robe Lighting s.r.o. - All rights reserved								
All Specifications subject to change without notice								

T15 - Colours on Virtual Colour Wheel					
Colour name	Red DMX	Green DMX	Blue DMX	Amber DMX	Lime DMX
Filter 4 (Medium Bastard Amber)	255	47	7	255	80
Filter 10 (Medium Yellow)	255	65	0	255	132
Filter 19 (Fire)	255	0	0	186	1
Filter 26 (Bright Red)	255	0	0	25	0
Filter 58 (Lavender)	255	0	68	255	44
Filter 68 (Sky Blue)	132	190	159	0	36
Filter 71 (Tokyo Blue)	0	0	255	0	0
Filter 79 (Just Blue)	123	147	171	0	56
Filter 88 (Lime Green)	255	237	2	198	185
Filter 90 (Dark Yellow Green)	0	255	2	0	169
Filter 100 (Spring Yellow)	255	0	0	255	223
Filter 101 (Yellow)	255	0	0	255	157
Filter 102 (Light Amber)	255	142	4	255	73
Filter 103 (Straw)	255	138	4	255	97
Filter 104 (Deep Amber)	255	0	0	255	124
Filter 105 (Orange)	255	0	0	255	60
Filter 106 (Primary Red)	255	0	0	104	0
Filter 111 (Dark Pink)	255	0	11	255	59
Filter 115 (Peacock Blue)	0	255	31	0	72
Filter 116 (Medium Blue-Green)	0	255	20	0	63
Filter 117 (Steel Blue)	45	255	42	158	183
Filter 118 (Light Blue)	4	255	37	0	77
Filter 119 (Dark Blue)	0	165	118	0	0
Filter 120 (Deep Blue)	3	165	111	0	0
Filter 121 (Filter Green)	84	255	0	235	24
Filter 128 (Bright Pink)	255	0	10	127	0
Filter 131 (Marine Blue)	0	255	75	51	116
Filter 132 (Medium Blue)	0	255	102	0	42
Filter 134 (Golden Amber)	255	51	0	255	42
Filter 135 (Deep Golden Amber)	255	35	0	255	0
Filter 136 (Pale Lavender)	184	7	51	255	60
Filter 137 (Special Lavender)	231	63	43	255	99
Filter 138 (Pale Green)	255	224	6	255	200
Filter 139 (Primary Green)	0	255	0	0	84
Filter 141 (Bright Blue)	0	255	77	0	82
Filter 147 (Apricot)	255	0	4	255	115
Filter 148 (Bright Rose)	255	0	7	255	13
Filter 152 (Pale Gold)	255	0	11	255	112
Filter 154 (Pale Rose)	255	0	16	255	119
Filter 157 (Pink)	255	0	7	255	27
Filter 158 (Deep Orange)	255	0	0	255	30
Filter 162 (Bastard Amber)	255	175	7	255	50
Filter 164 (Flame Red)	255	0	0	142	0
Filter 165 (Daylight Blue)	12	255	158	3	156
Filter 169 (Lilac Tint)	255	12	27	255	61
Filter 170 (Deep Lavender)	255	0	65	255	90
Filter 172 (Lagoon Blue)	0	238	113	0	255

Colour name	Red DMX	Green DMX	Blue DMX	Amber DMX	Lime DMX
Filter 179 (Chrome Orange)	255	0	0	255	112
Filter 180 (Dark Lavender)	92	15	188	76	46
Filter 181 (Congo Blue)	185	0	214	0	0
Filter 197 (Alice Blue)	0	249	163	39	0
Filter 201 (Full C.T. Blue)	38	150	97	36	246
Filter 202 (Half C.T. Blue)	164	13	123	34	255
Filter 203 (Quarter C.T. Blue)	255	203	54	104	255
Filter 204 (Full C.T. Orange)	255	125	0	255	4
Filter 205 (Half C.T. Orange)	255	139	5	255	67
Filter 206 (Quarter C.T. Orange)	255	60	17	255	98
Filter 247 (Filter Minus Green)	255	28	36	255	56
Filter 248 (Half Minus Green)	255	20	45	255	200
Filter 281 (Three Quarter C.T. Blue)	38	255	102	136	227
Filter 285 (Three Quarter C.T. Orange)	255	0	0	255	121
Filter 352 (Glacier Blue)	16	255	119	5	149
Filter 353 (Lighter Blue)	14	255	66	0	157
Filter 715 (Cabana Blue)	0	222	182	0	0
Filter 778 (Millennium Gold)	255	0	0	255	37
Filter 793 (Vanity Fair)	255	0	26	171	0