

ROBE

Forte[®] PC

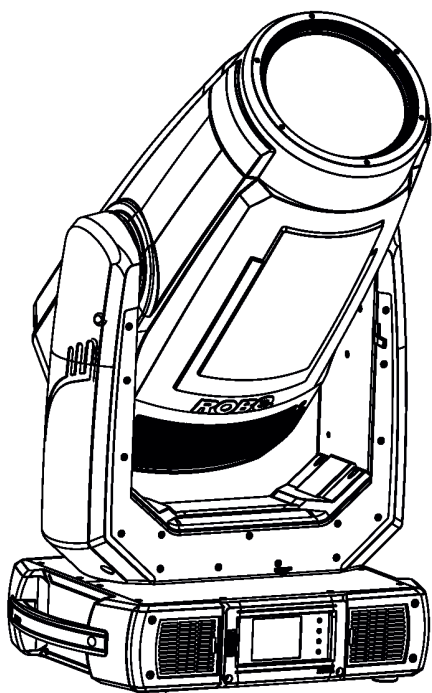

Forte[®] Fresnel

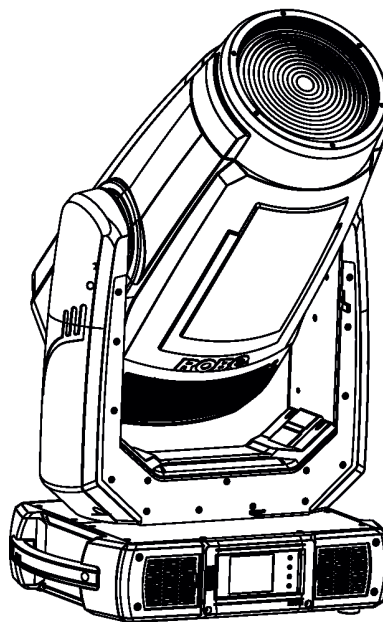

ROBE
Innovative
Technology

QR code for user manual



USER MANUAL

ROBE[®] lighting s.r.o. • Czech Republic • www.robe.cz

Version 1.3.

Forte Fresnel

Forte PC

Table of contents

1. Safety instructions	3
2. Operating determination	4
3. Fixture exterior view	6
4. Installation	7
4.1 Connection to the mains	7
4.2 Replacing the frosts	7
4.3 Fresnel lens/PC lens module installation	8
4.4 Rigging the fixture	9
4.5 DMX-512 connection.....	11
4.6 Ethernet connection	12
4.7 Wireless DMX operation	14
5. Remotely controllable functions	15
6. Control menu map	17
7. Control menu	21
7.1 Tab "Address"	22
7.2 Tab "Information"	23
7.3 Tab "Personality"	26
7.4 Tab "Manual Control".....	28
7.5 Tab "Stand-alone"	28
7.6 Tab "Service"	29
8. RDM	32
9. Robe Ethernet Access Portal (REAP)	33
10. Error and information messages	33
11. NFC	37
12. Technical Specifications	38
13. Maintenance and cleaning	41
13.1 Disposing of the product	42
14. ChangeLog	42
15. Appendix	43
15.1 Changing the LED light source	43
15.2. Obtaining information about the LED light source by mobile phone	48

CAUTION!

***Keep this device away from rain and moisture!
Unplug mains lead before opening the housing!***

**FOR YOUR OWN SAFETY, PLEASE READ THIS USER MANUAL CAREFULLY
BEFORE YOU INITIAL START - UP!**

1. Safety instructions

Please use only an original ROBE packaging (paper box, loader case or foam shell) for transporting the device, otherwise potential damage of the device during its transport will not subject to warranty.

CAUTION!

***Be careful with your operations.
With a high voltage you can suffer
a dangerous electric shock when touching the wires!***

This device has left our premises in absolutely perfect condition. In order to maintain this condition and to ensure a safe operation, it is absolutely necessary for the user to follow the safety instructions and warning notes written in this manual.

The manufacturer will not accept liability for any resulting damages caused by the non-observance of this manual or any unauthorized modification to the device.

Please consider that damages caused by manual modifications to the device are not subject to warranty.

Never let the power-cord come into contact with other cables! Handle the power cord and all connections with the mains with particular caution!

Make sure that the available voltage is not higher than stated on the rear panel.

WARNING! This unit does not contain an ON/OFF switch. Always disconnect power input cable to completely remove power from unit when not in use or before cleaning or servicing the unit.

Make sure that the power cord is never crimped or damaged by sharp edges. Check the device and the power-cord from time to time.

Always disconnect from the mains, when the device is not in use or before cleaning it. Only handle the power-cord by the plug. Never pull out the plug by tugging the power cord.

This device falls under protection class I. Therefore it is essential to connect the yellow/green conductor to earth. The electric connection, repairs and servicing must be carried out by a qualified employee.

Do not connect this device to a dimmer pack.

During the initial start-up some smoke or smell may arise. This is a normal process and does not necessarily mean that the device is defective.

Do not touch the device's housing bare hands during its operation (housing becomes hot)!

For replacement use fuses of same type and rating only.

***LED light emission. Risk of eye injury.
Do not look straight at the fixture's LED source during operation. The intense light beam may damage your eyes.***

Do not view the light output with optical instruments or any device that may concentrate the beam.

CAUTION! Risk group 2, RG-2



2. Operating determination

This device is a moving head for creating decorative effects and was designed for indoor use only. This device is for professional use only. It is not for household use.

If the device has been exposed to drastic temperature fluctuation (e.g. after transportation), do not switch it on immediately. The arising condensation water might damage your device. Leave the device switched off until it has reached room temperature.

Do not shake the device. Avoid brute force when installing or operating the device.

Never lift the fixture by holding it at the projector-head, as the mechanics may be damaged. Always hold the fixture at the transport handles.

When choosing the installation spot, please make sure that the device is not exposed to extreme heat, moisture or dust. There should not be any cables lying around. You endanger your own and the safety of others!

Make sure that the area below the installation place is blocked when rigging, de-rigging or servicing the fixture. Always fix the fixture with an appropriate safety wire. Fix the safety wire at the correct holes only.

Only operate the fixture after having checked that the housing is firmly closed and all screws are tightly fastened.

The maximum ambient temperature 45°C must never be exceeded.

CAUTION!

The front lens has to be replaced when it is obviously damaged, so that its function is impaired, e. g. due to cracks or deep scratches!

Operate the device only after having familiarized with its functions. Do not permit operation by persons not qualified for operating the device. Most damages are the result of unprofessional operation!

Do not block the front objective lens with any object when the fixture is under operation. The fixture housing never must be covered with cloth or other materials.

Please use the original packaging if the device is to be transported.

Please consider that unauthorized modifications on the device are forbidden due to safety reasons!

If this device will be operated in any way different to the one described in this manual, the product may suffer damages and the guarantee becomes void. Furthermore, any other operation may lead to dangers like short-circuit, burns, electric shock, burns etc.

CAUTION!

To avoid damage of the internal parts of the fixture head, never let the sunlight lights directly to the front lens , even when the fixture is not working !

The product (covers and cables) must not be exposed to a high frequency electromagnetic field higher than 3V/m.

Immunity of the equipment is designed according to the standard EN 55035 Electromagnetic compatibility of multimedia equipment - Immunity requirements.

Emission of the equipment complies with the standard EN55032 Electromagnetic compatibility of multimedia equipment – Emission Requirements according to class B.

Contains FCC ID: 2A6PL-DMXRDMRW001

Contains IC: 29573-DMXRDMRW001

This device complies with part 15 of the FCC Rules. Operation is subject to the following two conditions: (1) This device may not cause harmful interference, and (2) this device must accept any interference received, including interference that may cause undesired operation.

Changes or modifications not expressly approved by the party responsible for compliance could void the user's authority to operate the equipment.

The [Device] wireless operation is safe and complies to RF Exposure requirements

This equipment has been tested and found to comply with the limits for a Class B digital device, pursuant to part 15 of the FCC Rules. These limits are designed to provide reasonable protection against harmful interference in a residential installation. This equipment generates, uses and can radiate radio frequency energy and, if not installed and used in accordance with the instructions, may cause harmful interference to radio communications. However, there is no guarantee that interference will not occur in a particular installation. If this equipment does cause harmful interference to radio or television reception, which can be determined by turning the equipment off and on, the user is encouraged to try to correct the interference by one or more of the following measures:

- Reorient or relocate the receiving antenna.
- Increase the separation between the equipment and receiver.
- Connect the equipment into an outlet on a circuit different from that to which the receiver is connected.
- Consult the dealer or an experienced radio/TV technician for help.

3. Fixture exterior view

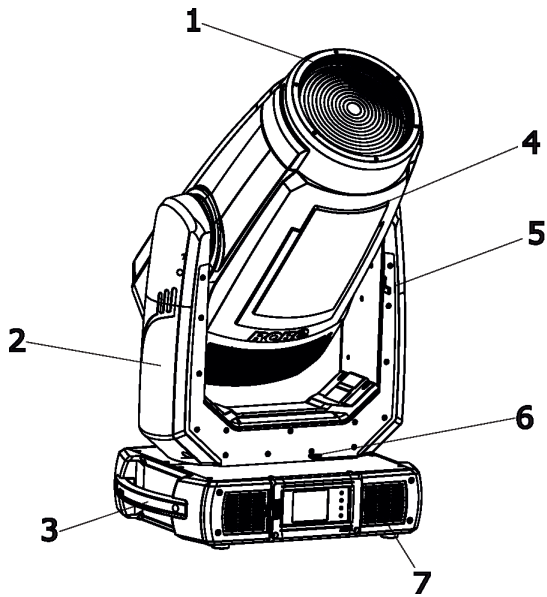

- 1 - Front Fresnel lens /PC Lens
- 2 - Arm
- 3- Handle
- 4 - Moving head
- 5 - Tilt lock
- 6 - Pan lock
- 7 - Base

The head has to be locked for transportation- the tilt lock latch (5) and the pan lock latch (6) have to be in the locked positions. To unlock the head, move these latches to unlock position before operating the fixture.

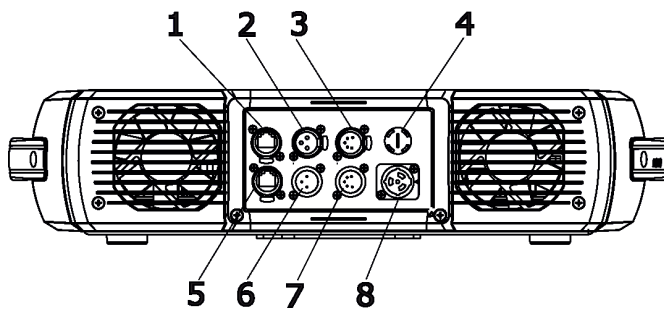

Rear panel of the base

- 1 - Ethernet In (RJ45)
- 2 - 3-pin DMX Out
- 3 - 5-pin DMX Out
- 4 - Fuse holder
- 5 - Ethernet Out (RJ45)
- 6 - 3-pin DMX In
- 7 - 5-pin DMX In
- 8 - Power (PowerCon True 1)

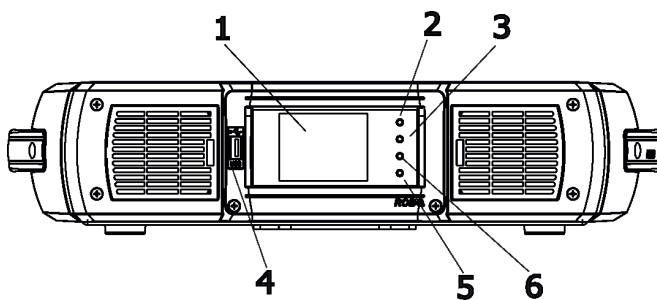

Front panel of the base:

- 1 - QVGA touch screen
- 2 - ESCAPE button
- 3 - NEXT button
- 4 - USB port
- 5 - ENTER/DISPLAY ON button
- 6 - PREV button

The ENTER/DISPLAY ON button also serves for switching the display on when the fixture is disconnected from the mains.

4. Installation



Fixtures must be installed by a qualified electrician in accordance with all national and local electrical and construction codes and regulations.

4.1 Connection to the mains

For protection from electric shock, the fixture must be earthed!

The Robin Forte Fresnel/Forte PC is equipped with auto-switching power supply that automatically adjusts to any 50-60Hz AC power source from 100-240 Volts.

Power cable is enclosed to the fixture. If you need to install a power plug on the power cable to allow connection to power outlets, install a grounding-type (earthed) plug, following the plug manufacturer's instructions. If you have any doubts about proper installation, consult a qualified electrician.

Core (EU)	Core (US)	Connection	Plug Terminal Marking
Brown	Black	Live	L
Light blue	White	Neutral	N
Yellow/Green	Green	Earth	PE/GND

This device falls under class one and must be earthed (grounded).
To apply power, first check that the pan and tilt locks are released.

4.2 Replacing the frosts

Unplug the fixture from mains before replacing the frosts!

To replace the frost.

1. Disconnect the fixture from mains and allow it to cool for 10 minutes.
2. Remove plastic cover of the head by loosening the 2 quarter-turn fasteners on the cover to get access to the 5° frost (1) and 10° frost (7).

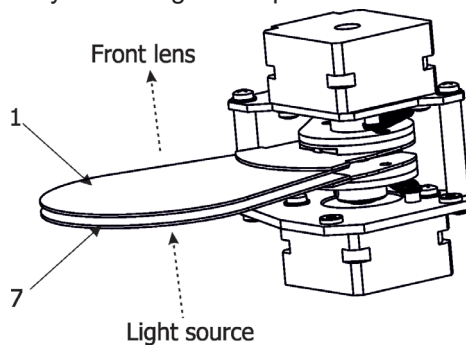

3. The holder (2) of the frost foil is fastened to the frost holder (3) by means of the four magnets (4). Grip the holder (2) and carefully tilt it out to break a force of magnets (4) on the frost holder (3).

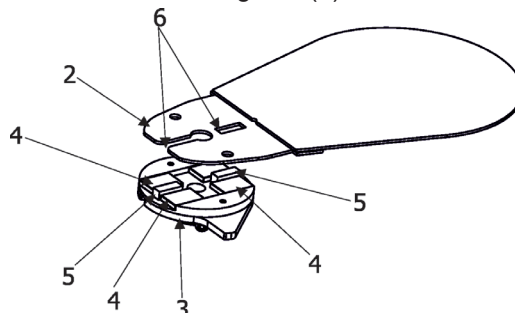

4. Place a new frost module into the frost holder (3). Check, that both slots (6) snapped correctly into two protrusions (5) in the holder (3).
5. Place the plastic cover back on the fixture before applying power.

4.3 Fresnel lens/PC lens module installation

***Install the front lens with the device unplug from mains.
The front lens is heavy!
Secure the head in a horizontal position by means of the pan/tilt locks before
lens replacing.***

1. Disconnect the fixture from mains and allow it to cool.
2. Remove both head covers.
3. Secure the fixture head in a horizontal position by means of the pan/tilt locks.
4. Unscrew two screws (4) on each side of the fixture head and remove the spot lens module (5). Be careful, the lens module is heavy!
5. Place the Fresnel lens or PC lens module on the head and fasten it by means of the four screws (4). Check that all screws are fully tightened before placing the head covers back on the head.
6. Place head covers on the head and secure them by means of securing wires and quick-lock fasteners on each cover.

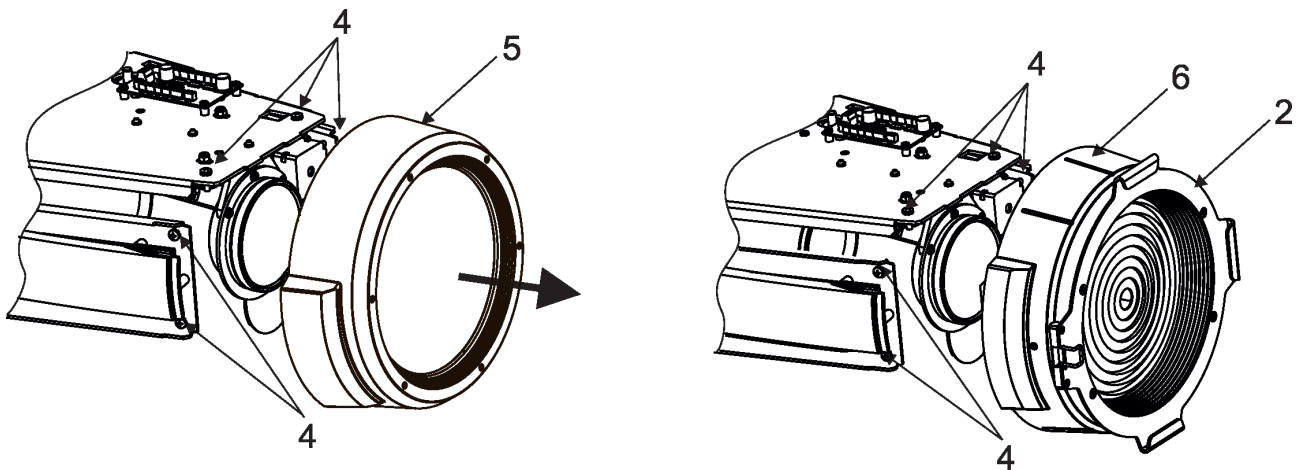

4.4 Rigging the fixture

A structure intended for installation of the fixture(s) must safely hold weight of the fixture(s) placed on it. The structure has to be certificated to the purpose.

The fixture (fixtures) must be installed in accordance with national and local electrical and construction codes and regulations.

For overhead installation, the fixture must be always secured with a safety wire that can bear at least 10 times the weight of the fixture

When rigging, derigging or servicing the fixture staying in the area below the installation place, on bridges, under high working places and other endangered areas is forbidden.

The operator has to make sure that safety relating and machine technical installations are approved by an expert before taking into operation for the first time and after changes before taking into operation another time.

The operator has to make sure that safety relating and machine technical installations are approved by a skilled person once a year.

Allow the fixture to cool for ten minutes before handling.

The projector should be installed outside areas where persons may walk by or be seated.

IMPORTANT! OVERHEAD RIGGING REQUIRES EXTENSIVE EXPERIENCE, including calculating working load limits, installation material being used, and periodic safety inspection of all installation material and the projector. If you lack these qualifications, do not attempt the installation yourself, but use a help of professional companies.

CAUTION: Fixtures may cause severe injuries when crashing down! If you have doubts concerning the safety of a possible installation, do not install the fixture!

The fixture has to be installed out of the reach of public.

The fixture must never be fixed swinging freely in the room.

***Danger of fire !
When installing the device, make sure there is no highly inflammable material (decoration articles, etc.) in a distance of min. 1 m.***

***CAUTION!
Use 2 appropriate clamps to rig the fixture on the truss.
Follow the instructions mentioned at the bottom of the base.
Make sure that the device is fixed properly! Ensure that the structure (truss) to which you are attaching the fixtures is secure.***

The fixture can be placed directly on the stage floor or rigged in any orientation on a truss without altering its operation characteristics .

For securing the fixture to the truss, install a safety wire which can hold at least 10 times the weight of the fixture. Use only the safety wire with a snap hook with screw lock gate.

Omega holders positions

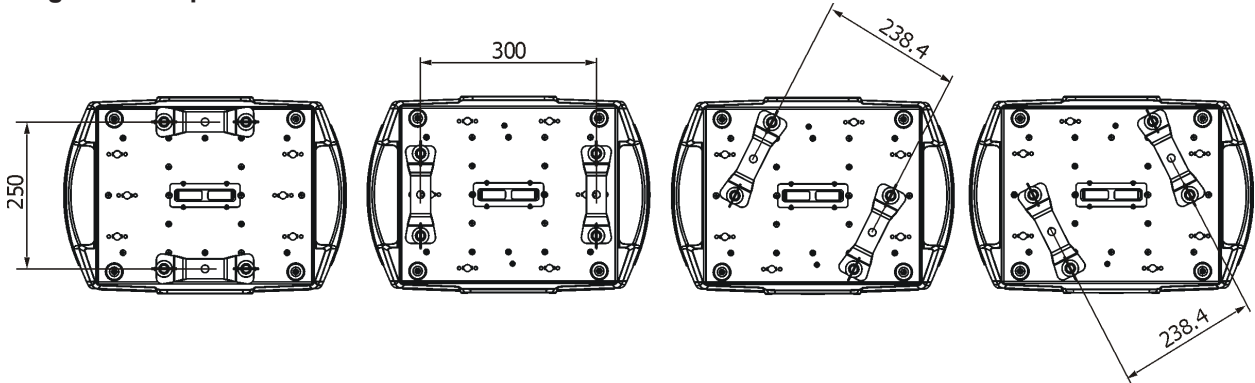

Truss installation

1. Bolt each clamp (1) to the omega holder (2) with M12 bolt and lock nut through the hole in the holder.
2. Fasten the omega holders to the bottom of the base by inserting both quick-lock fasteners (3) into the holes of the base and tighten fully clockwise.
3. Clamp the fixture on a truss (6) and tighten the rigging clamps.
4. Pull one safety wire (4) around the truss (6) and through the handle (7) and another safety wire (4) pull around the truss (6) and through the handle (7) and lock the snap hook of the safety wire in the attachment point (5) as shown on the picture below. Use the safety wire of a suitable length that maximum fall of the fixture will be 20 cm.

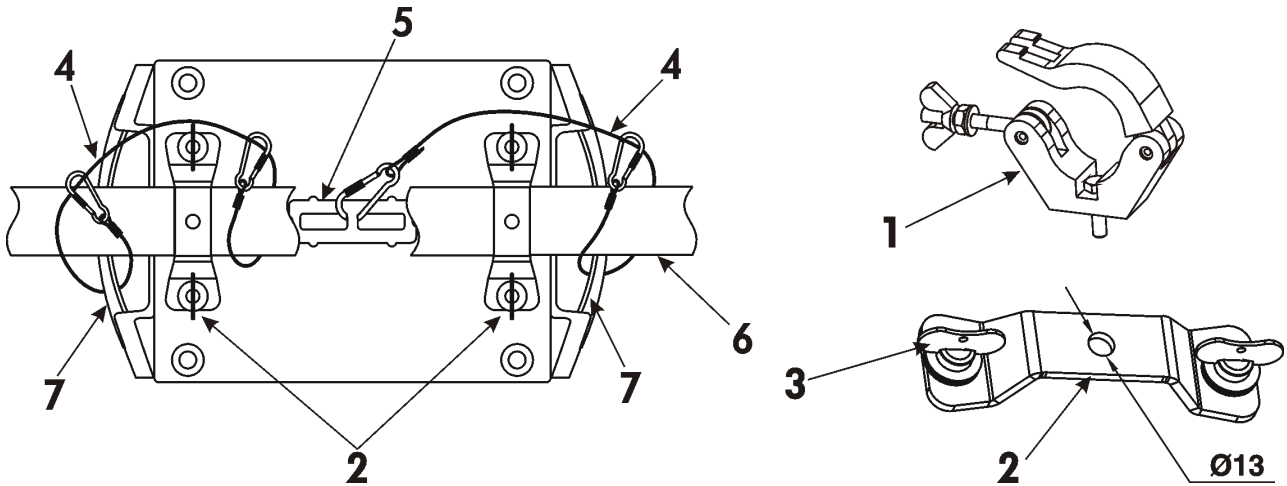

- 1-Clamp
- 2-Omega holder
- 3-Quick-lock fastener
- 4-Safety wire
- 5-Attachment point
- 6-Truss
- 7-Handle

***When installing fixtures side-by-side,
avoid illuminating one fixture with another!***

DANGER TO LIFE!
***Before taking into operation for the first time, the installation has to be approved by
an expert!***

4.5 DMX-512 connection

The fixture is equipped with both 3-pin and 5-pin XLR sockets for DMX input and output. The sockets are wired in parallel.

Only use a shielded twisted-pair cable designed for RS-485 and 3-pin or 5-pin XLR-plugs and connectors in order to connect the controller with the fixture or one fixture with another.

DMX output

XLR sockets (female)

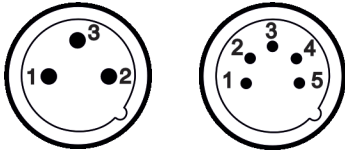

- 1 - Shield
- 2 - Signal (-)
- 3 - Signal (+)
- 4 - Not connected
- 5 - Not connected

DMX input

XLR sockets (male)

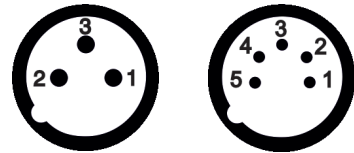

If you are using the standard DMX controllers, you can connect the DMX output of the controller directly with the DMX input of the first fixture in the DMX chain. If you wish to connect DMX controllers with other XLR outputs, you need to use adapter cables.

Building a serial DMX chain:

Connect the DMX output of the first fixture in the DMX chain with the DMX input of the next fixture. Always connect one output with the input of the next fixture until all fixtures are connected. Up to 32 fixtures can be connected.

Caution: At the last fixture, the DMX cable has to be terminated with a terminator. Solder a 120 Ω resistor between Signal (-) and Signal (+) into a 3-pin XLR plug and plug it in the DMX output of the last fixture.

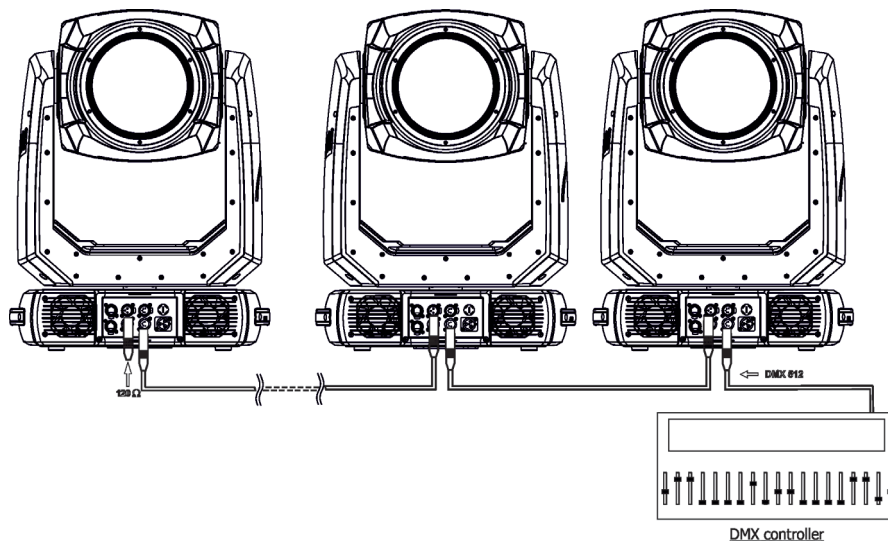

4.6 Ethernet connection

The fixtures on a data link are connected to the Ethernet with appropriate communication protocol (e.g. Art-Net). The control software running on your PC (or light console) has to support Art-Net protocol.

Art-Net communication protocol is a 10 Base T Ethernet protocol based on the TCP/IP. Its purpose is to allow transfer of large amounts of DMX 512 data over a wide area using standard network technology.

IP address is the Internet protocol address. The IP uniquely identifies any node (fixture) on a network.

The Universe is a single DMX 512 frame of 512 channels.

The Robin Forte is equipped with 8-pin RJ-45 sockets for Ethernet connection. Use a network cable category 5 (with four “twisted” wire pairs) and standard RJ-45 plugs in order to connect the fixture to the network.

RJ-45 socket (front view):

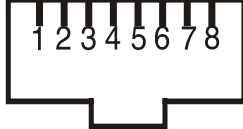

- | | |
|------------------|------------------|
| 1- TD+ | 5- Not connected |
| 2- TD- | 6- RX- |
| 3- RX+ | 7- Not connected |
| 4- Not connected | 8- Not connected |

RJ-45 plug (front view):

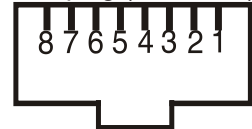

Patch cables that connect fixtures to the hubs or LAN sockets are wired 1:1, that is, pins with the same numbers are connected together:



If only the fixture and the computer are to be interconnected, no hubs or other active components are needed. A cross-cable has to be used:



If the fixture is connected with active Ethernet socket (e.g. switch) the network icon  will appear at the bottom right corner of the screen:

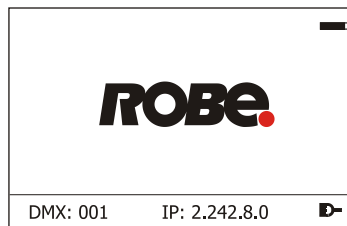

Ethernet operation

Connect the Ethernet inputs of all fixtures with the Ethernet network.

Option “Artnet” (gMal or gMA2 or sACN) has to be selected from “Ethernet Mode” menu at each fixture.

Set IP address (002.xxx.xxx.xxx / 010.xxx.xxx.xxx) and the Universe at each fixture.

(DMX address=163)
IP address=002.168.002.004
Universe=1

(DMX address=55)
IP address=002.168.002.003
Universe=1

(DMX address=1)
IP address=002.168.002.002
Universe=1

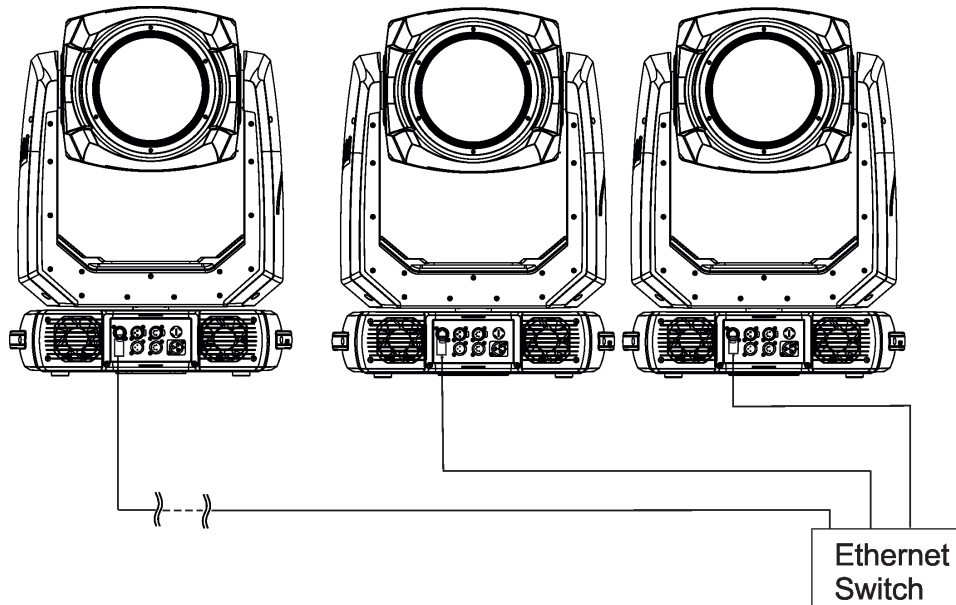

An advised PC setting: IP address: 002.xxx.xxx.xxx (Different from fixture IP addresses)
NET mask: 255.0.0.0

The fixture is equipped with Ethernet Pass Through Switch which sustains Ethernet integrity, when the fixture has no power, it automatically maintains network connectivity.

If you use the Ethernet IN-OUT way for the Ethernet connection, max. 8 fixtures can be connected in the IN-OUT line.

Ethernet / DMX operation

Option "Artnet" (gMal or gMA2 or sACN) has to be selected from "Ethernet Mode" menu at first fixture.

Option "Ethernet To DMX" has to be selected from the "Ethernet Mode" menu at the first fixture (connected to the Ethernet) in the fixture chain, next fixtures have standard DMX setting.

Connect the Ethernet input of the first fixture in the data chain with the network. Connect the DMX output of this fixture with the input of the next fixture until all fixtures are connected to the DMX chain.

Caution: At the last fixture, the DMX chain has to be terminated with a terminator. Solder a 120 Ω resistor between Signal (-) and Signal (+) into a XLR-plug and connect it in the DMX-output of the last fixture.

Example:

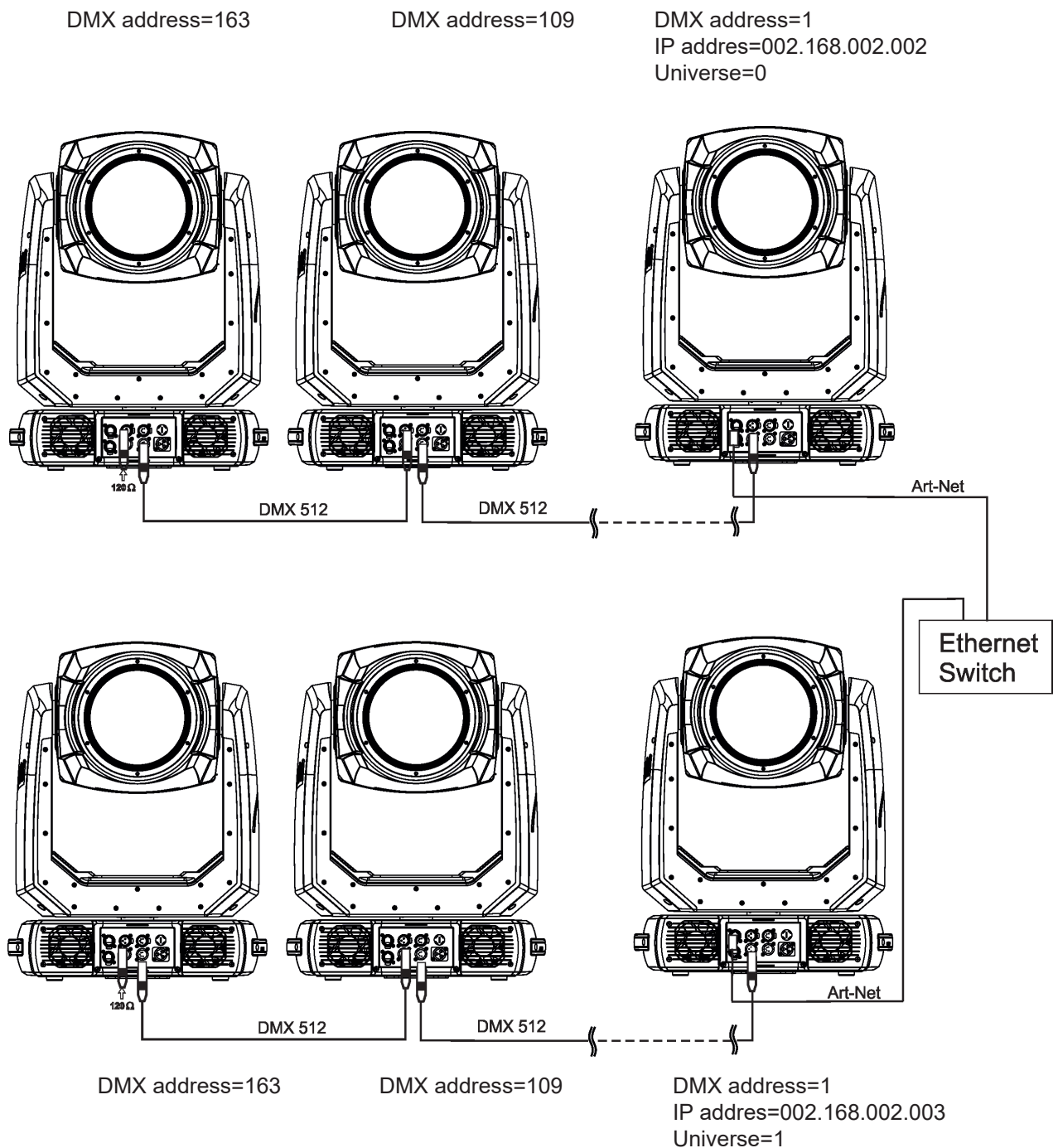

4.7 Wireless DMX operation

The wireless DMX version of the fixture is equipped with the wireless DMX/RDM module which has full support for wireless communication protocols at entertainment market. The module is based on well known Lumen-Radio RF technology, with implemented wire interface for connection with Robe products. RF output for MCX interface antenna as standard output.

The item " Wireless " from the menu "DMX Input" allows you to activate receiving of wireless DMX (Personality--> DMX Input -->Wireless.). First two options from the "DMX Input" menu are stated in DMX chart as well (channel Power/Special functions , range of 10-19 DMX). If DMX input option is changed by DMX command, the change is permanently written into fixture's memory.

DMX range of 10-19 switching fixture to the wired/wireless operation is active only during first 10 seconds after switching the fixture on.

After switching the fixture on, the fixture checks both modes of receiving DMX in the following order:

1. For the first five seconds, the fixture receives DMX signal from the wired input. If the Power/Special functions channel is set at some DMX input option, the fixture will receive DMX value according to this option. If DMX input option is set to the wired input , this option is saved and checking procedure is finished. If DMX input option is not set, the fixture continues next 5 seconds in scanning wireless DMX signal-see point 2.

2. For the next 5 seconds the fixture receives wireless DMX signal and again detects if the Power/Special functions channel is set at some DMX input option, if not, the fixture will take option which is set in the fixture menu "DMX Input".

To link the fixture with DMX transmitter.

The fixture can be only linked with the transmitter by running the link procedure at DMX transmitter .

After linking , the level of DMX signal (0-100 %) is displayed in the menu item "Wireless State" (Information -->Wireless State).

To unlink the fixture from DMX transmitter.

The fixture can be unlinked from transmitter via the menu item " Unlink Wireless Adapter" (Information--> Wireless State --> Unlink Wireless Adaptor).

Note: If the option "Wireless In/XLR Out" is selected (Personality--> DMX Input -->Wireless In/XLR Out), the fixture receives wireless DMX and sends the signal to its wired DMX output. The fixture behaves as " Wireless/ Wired" adaptor.

Example of connection:

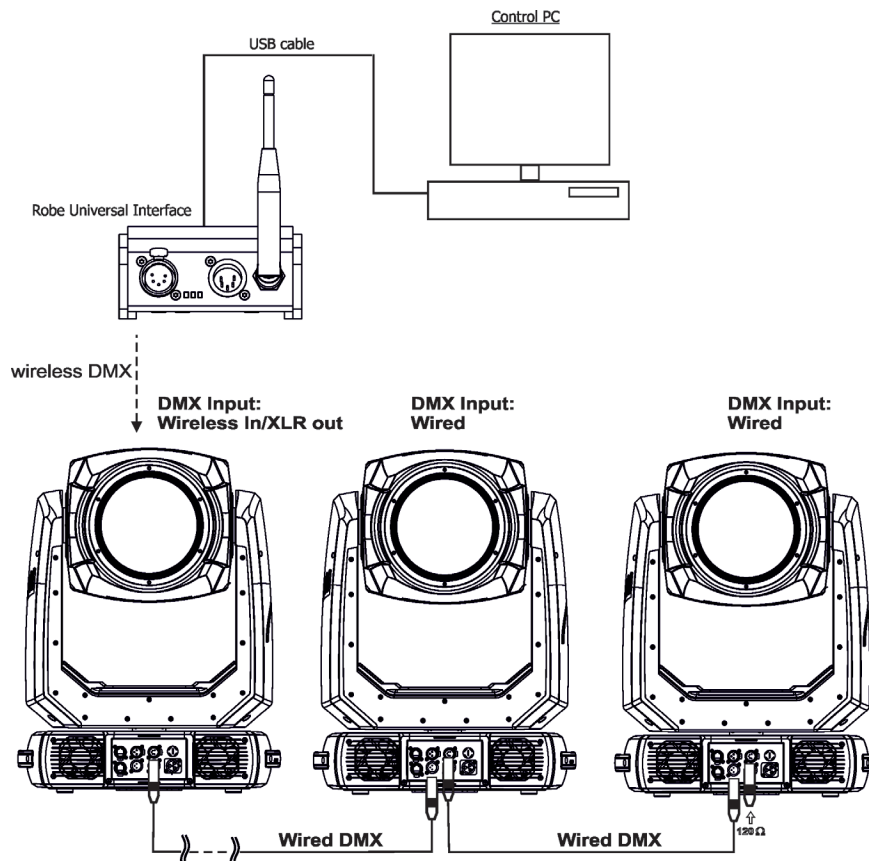

5. Remotely controllable functions

Scrim effect

Indexable scrim effect by 360°. Fine inserting into light beam.

Image on the wall

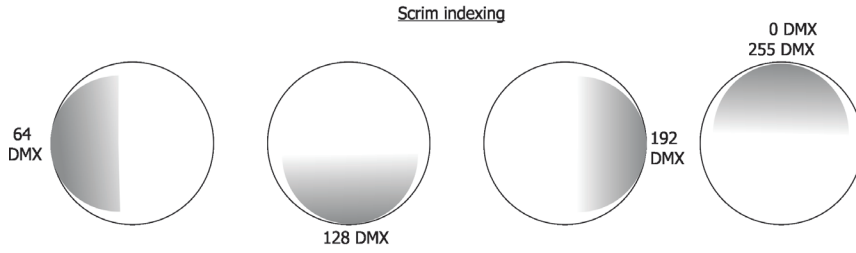

Head position

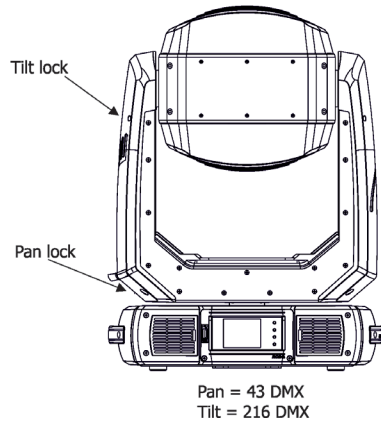

Barndoors

The fixture uses an internal barndoors module for creating different shapes, which also simulates barn door effects. The barndoors module consists of four individually controllable blades and is rotatable by 180 degrees.

Image on the wall

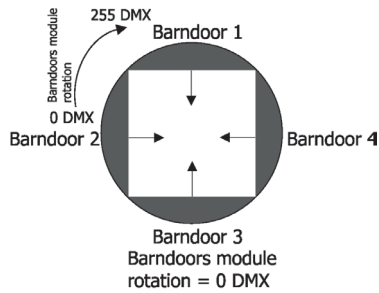

Head position

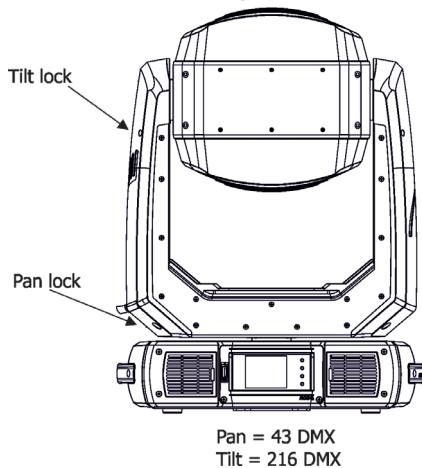

Frost

Two frost filters (light 5° and medium 10°) provide variable frost for fine frosting. Both frosts are replaceable.

Zoom

Motorized zoom unit enables zoom in range of 5.5°-62° (Forte PC) / 6°-61° (Forte Fresnel)

Pan/Tilt

Fast pan/tilt movement due to built-in electronic motion stabilizer (EMS). The electronic motion stabilizer ensures precise position of the fixture's head during its movement and reduces its swinging when the truss shakes. Pan /Tilt movement range: 0-540°/0-270°.

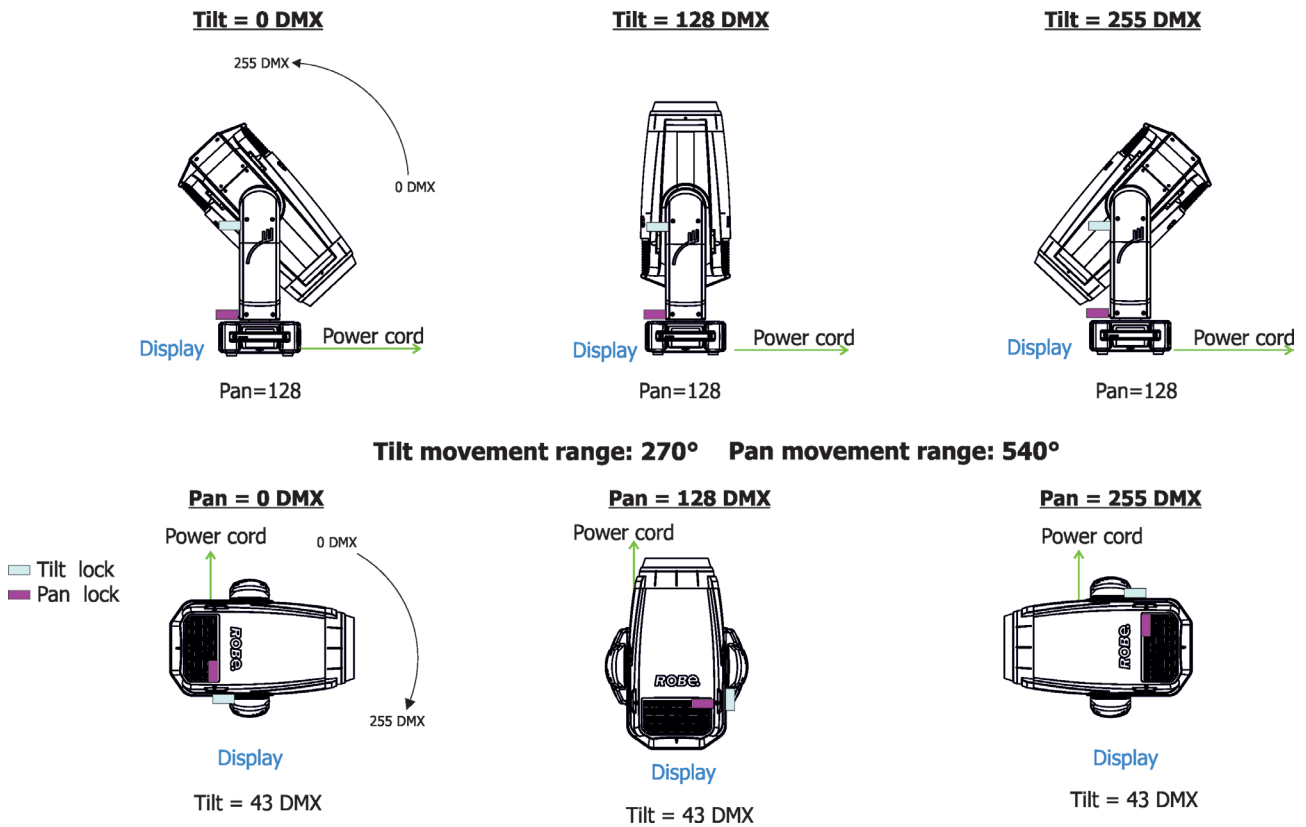

Colour wheel 1

This wheel contains five dichroic filters + open. The colour wheel can be positioned between two adjacent colours in any position. It is also possible to rotate the colour wheel continuously at different speeds ("Rainbow effect" in both directions).

Colour wheel 2

This wheel contains one multicolour filter, two dichroic filters and two CRI filters (80, 90) + open. The colour wheel can be positioned between two adjacent colours in any position. It is also possible to rotate the colour wheel continuously at different speeds ("Rainbow effect" in both directions).

CMY+CTO colour mixing system



The CMY color mixing system is based on graduated cyan, magenta, and yellow colour filters. A continuous range of colors may be achieved by varying the amount of each filter from 0 to 100%.

6. Control menu map

Default settings=**Bold print**

Tab	Level 1	Level 2	Level 3	Level 4	Level 5	Level 6
Addressing	Settings	DMX Address	001-512			
	DMX Preset channels	Mode 1				
	Ethernet Settings	Ethernet Mode	Disable			
			ArtNet			
			gMA1			
			gMA2			
			sACN			
		Ethernet To DMX	Off , On			
		IP Address/Net Mask	Default IP Address			
			Custom IP Address			
			Net Mask			
		ArtNet Universe	0-255			
		MANet settings	MANet/II Universe	01-256		
			MANet Session ID	01-32		
		sACN Settings	sACN Universe	00001-32000		
Information	Fixture Times	Power On Time	Total Hours			
			Resetable Hours			
		Air Filters	Elapsed Time			
			Alert Period	10-300		
	Fixture Temperatures	LEDs Temperatures	Cur.rent			
			Maximum NonRes..			
			Maximum Res..			
		Driver Temperature	Cur.rent			
			Maximum NonRes..			
			Maximum Res..			
		Base Temperature	Current			
			Maximum NonRes.			
			Maximum Res.			
	DMX Values	Pan				
		:				
		Dimmer Fine				
	Wireless State	Signal Quality				
		Unlink Wireless Adapter				
	Power Channel state					
	Software Versions	Display System				
		Module M				
		Module L1				
		Module L2				
		Module O				
		Module F-A				
		Module F-B				
		Module G1				
		Module G2				
		Module P				
		Module C1				
		Module C2				

Tab	Level 1	Level 2	Level 3	Level 4	Level 5	Level 6
		Module FR				
	Product IDs	Mac Address				
		RDM UID				
		RDM Label				
	LED Module info	First Module Assembly				
		Actual Module Info				
		Assembly History				
		Intensity History				
	LED Modules History					
	View Logs	Fixture Errors				
		Fixture States	Power On			
			Power Off			
		Fixture Position				
		Fixture Temperatures	LEDs Temperature			
			Driver Temperatures			
			Base Temperatures			
Personality	User Mode	User A Settings				
		User B Settings				
	DMX Preset channels	Mode 1				
	DMX Input	Wired				
		Wireless				
		Wireless In/XLR Out				
	Pan/Tilt Settings	Pan Reverse	Off, On			
		Tilt Reverse	Off, On			
		Pan/Tilt Feedback	Off, On			
		Pan/Tilt mode	Time			
			Speed			
	Pan/Tilt Reset	With P/T				
		Without P/T				
		Tilt then Pan				
		Pan then Tilt				
	Pan/Tilt EMS	Off, On				
	Follow Spot Mode	Off				
		Soft				
		Medium				
		Hard				
	Microphone Sensitivity	1-10-20				
	Blackout Settings	Blackout During M.C.	Off, On			
		Blackout while:	Pan/Tilt moving	Off, On		
			Colour Wheel Moving	Off, On		
	Frequency Setup	300 Hz				
		600Hz				
		1200Hz				
		2400Hz				
		Frequency Adjust				
	Init Effect Positions	Pan	0-255			
		:				
		Dimmer Fine	0-255			
	Screen Settings	Display Intensity	1-10			
		Screen Saver Delay	Off-10min.			
		Touchscreen Lock	Off-10min.			

Tab	Level 1	Level 2	Level 3	Level 4	Level 5	Level 6
		Recalibrate Touchscreen				
		Display Orientation	Normal			
			Inverted			
			Auto			
	Temperature Unit	°C, °F				
	Fan Settings	Fan mode	Auto			
			High			
			Quiet			
			Super Quiet			
		Quiet - Blackout Fan Off	On, Off			
	Dimmer Curve	Linear				
		Square Law				
		Super Square Law				
	Date & Time Settings					
	Default Settings					
	Password Protection	Off, On				
	Reset Web Password					
Manual Control	Reset Functions	Total System Reset				
		Pan/Tilt reset				
		System Reset w/o P/T				
		Pan Reset				
		Tilt Reset				
		Color System Reset				
		Optics//Frost Res.				
		Barndoors/Scrim Reset				
	Manual Effect Control	Pan	0-255			
		:				
		Dimmer Fine	0-255			
Stand -Alone	Test Sequences	Dynamic Mode				
		Static Mode	Pan	0-255		
			Tilt	0-255		
			Zoom	0-255		
	MusicTrigger	Off, On				
	Preset Playback	None				
		Test				
		Prog. 1				
		Prog. 2				
	Play Program	Play Program 1				
		Play Program 2				
	Edit Program	Edit Program 1	Start Step	1-80		
		Edit Program 2	End Step	1-80		
			Edit Program Steps	Step 1	Pan	0-255
				:	:	
				:	Dimmer Fine	0-255
				:	Step Time	0-25,5 sec.
				Step 80	Pan	0-255
					:	
					Dimmer Fine	0-255
					Step Time	0-25,5 sec.
Service	Adjust DMX Values	Pan	0-255			
		:				
		Dimmer Fine	0-255			
	Calibrations	Calibrate Effects	Pan	0-255		

Tab	Level 1	Level 2	Level 3	Level 4	Level 5	Level 6
			Tilt	0-255		
			Colour Wheel 1	0-255		
			Colour Wheel 2	0-255		
			Zoom	0-255		
			Focus	0-255		
			Frost 1/1	0-255		
			Frost 1/2	0-255		
			Frost 2/1	0-255		
			Frost 2/2	0-255		
			Barndoors rot..	0-255		
			Barndoor 1 Move	0-255		
			Barndoor 2 Move	0-255		
			Barndoor 3 Move	0-255		
			Barndoor 4 Move	0-255		
			Scrim Positioning	0-255		
			Scrim infexing	0-255		
		Calibrate Pan/Tilt EMS				
		Load Default Calibrations				
	LEDs Measure					
	Update Software					

7. Control menu

The Robin Forte Fresnel/Forte PC is equipped with the QVGA Robe touch screen with battery backup which allows you to set the fixture's behaviour according to your needs, obtain information on its operation, control all range of effects and program it in stand-alone mode.

The fixture's menu can be controlled either by the control buttons or directly by touching the icon.

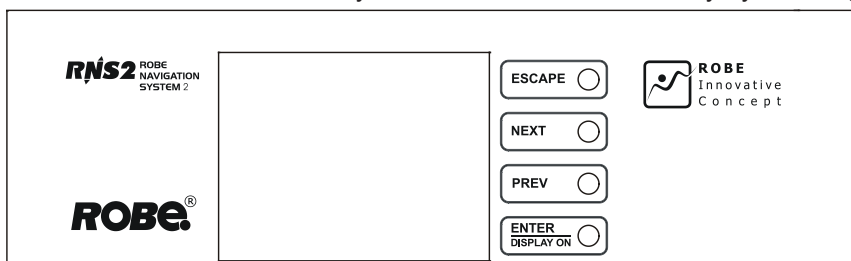

Control buttons on the front panel:

[ESCAPE] button used to leave the menu without saving changes.

[NEXT] , [PREV] buttons for moving between menu items and symbols, adjusting values.

[ENTER/Display On] button used to enter the selected menu (menu item) and to confirm adjusted value.

If the fixture is disconnected from mains, the button switches the touch screen on.

Icons used in the touch screen menu:



- [back arrow] used to move back to the previous screen (menu).



- [up arrow] used to move up on the previous page.



- [down arrow] used to move down on the next page.



- [confirm] used to save adjusted values, to leave menu or to perform desired action.



- [cancel] used to leave menu item without saving changes.



- [confirm+copy] used to save adjusted values and copy them to the next prog. step.



- [warning icon] used to indicate some error which has occurred in the fixture.



- [Ethernet] used to indicate Ethernet connected.



- [menu rotation] used to rotate menu 180 degrees from current orientation.



- [slider control] used to recall slider system for setting desired value.



- [keyboard control] used to recall keyboard system for setting desired value.



- [air filters cleaning] used to signal that cleaning period of the air filters elapsed.



- [QR code] used to show QR code for RDM UID of the fixture and LED engine serial number.

The menu page displays icons for each function that you can perform from the touch screen.

After switching the fixture on, the touch screen shows the screen with the ROBE logo.

Type of used LED engine in the fixture is displayed on the top line of the screen.

XP-type of LED engine used in the fixture.

-20% is a drop of max. light intensity set by the channel "Max. light intensity indication and setting".

Note: drop 0-5% is not signalized.

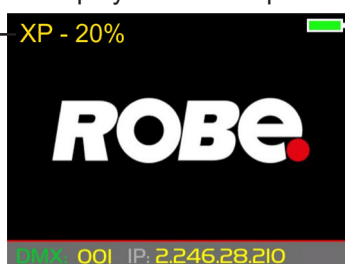

Battery indication

XP - Extra Performance Engine for maximum light output and optimal colour characteristics.

HCF - High Colour Fidelity Engine for the best light quality and colour reproduction.

The type of used LED engine is displayed if the fixture is disconnected from power as well.

Touch any part of the screen or press the [ENTER/Display On] button to display the initial screen with the current stored DMX address:

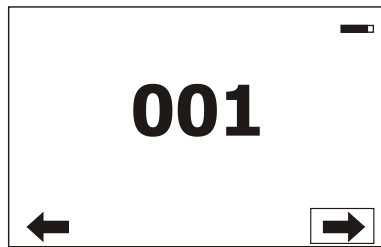

Note: The green icon at the top right corner of the screen indicates the level of the display battery charging. If the whole icon is green, the battery is fully charged while the red icon indicates exhausted battery. The battery charges during fixture operation, its charging lasts cca 6 hours.

We recommend that the fixture should be in operation at least 7 hours per week to keep the battery fully charged. If you switch the fixture on and this screen will not appear till 1 minute, switch the fixture off and on again. If the screen lights, the battery is exhausted. In case the screen still does not light, the battery is faulty.

This is also indicated by an error message "Faulty battery" and if such an error message appears the battery should be replaced immediately. The lifetime of the battery is highly dependent on ambient temperature (and consequently on base temperature). If the maximum ambient temperatures (as recorded and displayed in menu: Information -> Fixture Temperatures -> Ambient Temperature -> Maximum NonRes.) are kept within the specified limits, the battery should last for at least two years. Should the ambient temperatures exceed the specified maximum temperature, the lifetime of the batteries could be considerably shortened even up to just one year or less and also result in physical damage (battery leakage) or unreliable fixture functions.

Damage caused by batteries failed due to exceeded maximum ambient temperature cannot be claimed under warranty terms.

Touch the green arrow at the bottom right corner of the screen or press the [ENTER/Display On] button to enter the "Address" menu.

Each item (such as a Tab, menu item, text box, icon) may be selected from a screen by simply touching the item in the list or by pressing the [NEXT] or [PREV] buttons to scroll through list items. With each press, the next item is highlighted. Press [ENTER/Display On] to select the highlighted item.

Before first fixture operation, set current date and time in the menu "Date & Time Settings" (menu path: Personality--> Date & Time Settings).

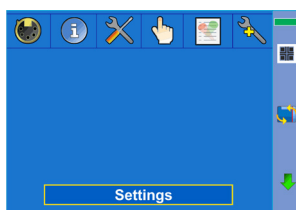

Icon for QR codes
Use [NEXT], [PREV]
buttons for moving
between QR codes

QR code for RDM UID of
the fixture.



QR code for serial number
of LED engine in the fixture.



(pictures for illustration only)

7.1 Tab "Address"



DMX Address - Select the menu to set the DMX start address.

Blinking DMX address means that the fixture is either not receiving DMX data or that the set DMX address is higher than allowed, exceeding the DMX footprint of the set DMX mode.

DMX Preset channels - The menu item allows you selection from two DMX modes.

Ethernet Settings - The menu allows all needed settings for the Ethernet operation

Ethernet Mode

Disable - The option disables Ethernet operation.

Artnet - Fixture receives Artnet protocol

gMAI - Fixture receives MANet 1 protocol

gMA2 - Fixture receives MANet 2 protocol

sACN - Fixture receives sACN protocol

Ethernet To DMX - Fixture receives protocol from the Ethernet input and sends DMX data to its DMX output (fixture works as an "Ethernet/DMX converter", next fixture can be connected to its DMX output and you can build a standard DMX chain by connecting another fixtures. Only one fixture has to be connected to the Ethernet.

IP Address/Net Mask - Select this menu to set IP address. IP address is the Internet protocol address. The IP uniquely identifies any node (fixture) on a network.

There cannot be 2 fixtures with the same IP address on the network!

Default IP Address -Preset IP address, you can set up only first byte of IP address (2 or 10) e.g. **002**.019.052.086.

Custom IP Address - The option enables to set up all bytes of IP address.

Net Mask - The option enables to set up all bytes of Net Mask.

ArtNet Universe - Use this item to set a Universe (0-255). The Universe is a single DMX 512 frame of 512 channels.

MANet Settings - Use this menu to set parameters for MANet operation.

MANet Universe I/II - The value of this item can be set in range 1-256.

MANet Session ID - The value of this item can be set in range 1-32.

sACN Settings - Use this menu to set parameters for sACN operation.

sACN Universe - The value of this item can be set in range 1-32000.

7.2 Tab "Information"



Fixture Times - The menu provides readouts of fixture and LED module operation hours.

Power On Time Hours - Select this menu to read the number of fixture operation hours.

Total Hours - The item shows the total number of the operation hours since the Robin Forte Fresnel/Forte PC has been fabricated.

Resetable Hours - The item shows the number of the operation hours that the Robin Forte Fresnel/Forte PC has been powered on since the counter was last reset.

In order to reset this counter to 0, touch the text box next to the item "Resetable Hours:"

Air Filters - Regular cleaning of the air filters is very important for the fixture's life and performance. Build-up of dust, dirt and fog fluid residues reduces the fixture's light output and cooling ability.

The two items of this menu help you to keep cleaning period of the air filters.

Alert period - Cleaning schedule for the fixture depends on the operating environment.

It is therefore impossible to specify accurate cleaning interval. This item allows you to change the cleaning interval of the air filters. This "alert" value is 300 hours and it is set as default. Inspect the fixture within its 300 hours of operation to see whether cleaning is necessary. If cleaning is required, clean all air filters and change the value in this menu on acceptable level. Min. level of alert period is 10 hours, max. is 300 hours.

Elapsed Time - The item allows you to read the time which remains to cleaning air filters.

The time period is set in the menu mentioned above.

Expired time period is signalled by a negative mark (-) at the time value and a warning icon on the display.

Clean the filters and reset this menu item (by touching the text box next to the item "Elapsed Time").

Fixture Temperatures - The menu is used to view temperatures of the fixture's inside.

LEDs temperature - The menu shows temperature on the LED PCB in the light source

Current - A current temperature of the LED PCB.

Maximum NonRes. - A maximum temperature of the LED PCB since the fixture has been fabricated.

Maximum Res. - A maximum temperature of the LED PCBs since the counter was last reset.

In order to reset some counter to 0, touch text box under item "Max.Res."

Driver Temperature - The menu shows temperature on the LEDs control PCB in the fixture head.

Current - A current temperature on the LEDs control PCB.

Maximum NonRes. - A maximum temperature on the LEDs control PCB since the fixture has been fabricated.

Maximum Res. - A maximum temperature on the LEDs control PCB since the counter was last reset.

In order to reset this counter to 0, touch the text box next to the item "Maximum Res."

Ambient Temperature - The menu shows temperature in the fixture base .

Current - A current temperature in the fixture base.

Maximum NonRes. - A maximum temperature in the fixture base since the fixture has been fabricated.

Maximum Res. - A maximum temperature in the fixture base since the counter was last reset.

In order to reset this counter to 0, touch the text box next to the item "Maximum Res."

Base Temperature - The menu shows temperature on the display PCB in the fixture base.

Current - A current temperature on the display PCB.

Maximum NonRes. - A maximum temperature on the display PCB since the fixture has been fabricated.

Maximum Res. - A maximum temperature on the display PCB since the counter was last reset.

In order to reset this counter to 0, touch the text box next to the item "Maximum Res."

DMX Values - The menu items allows you to read DMX values of each channel received by the fixture.

Wireless State - The menu serves for reading of the wireless operation status.

Unlink Wireless Adaptor - The item serves for unlinking the fixture from a DMX transmitter.

If the wireless module is not installed in the fixture, message "Wireless Module Not Installed" will appear.

Power Channel State - Select this item to see current setting of the functions, which can be set by menu items in "Personality" as well as by DMX command at channel "Power/Special functions".

Colour Functions State - Select this item to see current setting of the colour functions, which can be set by menu items in "Personality" as well as by DMX command at channel "Colour functions".

Software Version - Select this item to read the software version of the fixture processors:

Display System - A display processor on the display board in the fixture base

Module M - a Pan/Tilt processor

Module L 1 - a LEDs control processor 1

Module L 2 - a LEDs control processor 2

Module O - a Focus/Zoom/Light frost control processor

Module P - a Prisms/Medium frost control processor

Module C1 - a Colour wheel 1 control processor

Module C2 - a Colour wheel 2 control processor

Product IDs - The menu is used to read the MAC Address ,RDM UID and RDM Label.

LED Module Info - Use this menu to read LEDs module information.

First Module Assembly - Use the item to read initial information about the LEDs module installed in the fixture. The fixture has to be connected to mains to read the values in the menu items.

Serial Number/ Device UID - a serial number of the LEDs module/RDM UID of the fixture.

Installation Date/Time - a date/time of the first installation of the LEDs module to a some Forte device.

Intensity - an original intensity of the LEDs module in percentages (100%).

LEDs On Time Total/Adaptive - Total: a total time of the LEDs module operation during which

the dimmer intensity was > 0%.

Adaptive: a relative time of the LEDs module operation during which the dimmer intensity was > 0% (e.g. if dimmer = 50% for one hour, the adaptive time is 0.5 hour, if dimmer = 100% for one hour, the adaptive time is 1 hour).

Actual Module Info - Use the item to read current information about the LEDs module installed in the fixture.

Serial Number/ Device UID - a serial number of the LEDs module/RDM UID of the fixture.

Measurement Date/Time - a date/time of running the procedure "LEDs Measure" in the tab Service.

Intensity - the item shows a light intensity of the LEDs module measured after running the procedure "LEDs Measure" in the tab Service. The light intensity is displayed in percentages in relation to the initial intensity of the new LEDs module (initial intensity=100%).

LEDs On Time Total/Adaptive - Total: a total time of the LEDs module operation during which the dimmer intensity was > 0%.

Adaptive: a relative time of the LEDs module operation during which the dimmer intensity was > 0% (e.g. if dimmer = 50% for one hour, the adaptive time is 0.5 hour, if dimmer = 100% for one hour, the adaptive time is 1 hour).

Assembly History - Use the item to read a history of the LEDs module installed in the fixture (its serial number, RDM UID of fixture at which was installed and date/time of installation).

Up to 31 records can be saved in the menu item.

Intensity History - Use the item to read a history of light intensity of the LEDs module installed in the fixture.

Serial Number/ Device UID - a serial number of the LEDs module/RDM UID of the fixture.

Measurement Date/Time - a date/time of running the procedure "LEDs Measure" in the tab Service.

Intensity - the item shows a light intensity of the LEDs module measured after running the procedure "LEDs Measure" in the tab Service. The light intensity is displayed in percentages in relation to the initial intensity of the new LEDs module (initial intensity=100%) .

Up to 31 records can be saved in the menu item.

LED Modules History - Use the item to read a history of the LEDs modules installed in the fixture (their serial numbers and date/time of installation).

Up to 31 records can be saved in the menu item.

View Logs - Use this menu to read fixture's data which have been recorded during fixture operation. This collected data allows easier troubleshooting.

Fixture Errors - Use this menu to read fixture errors which have occurred during fixture operation.

Fixture States - In the menu are recorded fixture states as power on and power off.

Fixture Positions - In the menu are recorded installation positions of the fixture:

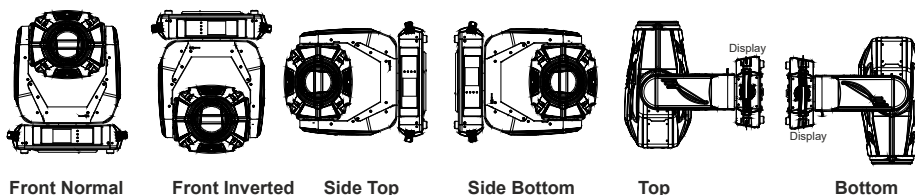

Fixture Temperatures - In the menu are recorded temperatures which have exceeded defined levels.

Note: The log buffer can contain max. 8000 records. If the buffer is full, old data will be overwritten.

7.3 Tab "Personality"



User mode - The Robin Forte Fresnel/Forte PC allows you to recall two user settings. After switching the fixture on for the first time, the User A settings is active. Now all changes made in the "Personality" menu, "Addressing" menu and the "Music Trigger" and "Preset Playback" items from the "Stand-alone" menu are saved to the User A settings. If you now select the User B settings, from this moment the changes made in these menus will be saved to the User B settings. After switching the fixture off and on, the User B setting is active. In this way you may use the two fixture operating behaviours.

User A Settings - the function recalls the user A settings.

User B Settings - the function recalls the user B settings.

DMX Preset - Use the menu to select desired channel mode.

Mode 1 - 35 control channels

View Selected Preset - Use the menu to display channels included in the selected mode.

DMX Input - Use the menu to select mode of DMX signal receiving.

Wired - DMX signal is received by means of the standard DMX cable.

Wireless - DMX signal is received by means of the inbuilt wireless module.

Wireless In/XLR Out - the fixture receives wireless DMX and sends the signal to its wired DMX output.

The fixture behaves as "Wireless/Wired" adapter.

The options "Wired" and "Wireless" are also stated in DMX chart (channel Power/Special functions).

Note. If the wireless module is not installed in the fixture, the following message will appear:

DMX Input Set to Wired

Wireless Module Missing

If the fixture is not connected to mains, the message "Not Available In Offline Mode" will appear after entering the menu DMX Input. To enter this menu, the fixture has to be connected to mains.

Pan/Tilt Settings - Use the menu set behaviour of both pan and tilt movements.

Pan Reverse - The item allows to invert pan movement.

Tilt Reverse - The item allows to invert tilt movement.

Pan/Tilt Feedback - The item allows to return the moving head to the required pan/tilt position after changing the position by an external force if this option is set on.

Note. Be careful, the Pan/Tilt Feedback should be permanent On, the option Off is not suitable for standard operation and the head of the fixture can be damaged!

Pan/Tilt mode - Use this menu to set the mode of the pan/tilt movement

Time mode – The pan and tilt will move with different speeds and they will come at the same time to the end point of their tracks (pan and tilt use their optimal speeds).

Time of the pan/tilt movement (25.5 sec. max.) is set by the channel "Pan/Tilt speed, Pan/Tilt time".

Speed Mode - Both Pan and tilt will move with the same speed as adjusted at the channel "Pan/Tilt speed, Pan/Tilt time".

Pan/Tilt Reset - This menu item allows you to choose a way of pan/tilt reset after switching the fixture on

With P/T - With pan and tilt - the item will reset both pan and tilt simultaneously after switching the fixture on.

Without P/T - Without pan and tilt reset after switching the fixture on. The pan and tilt reset can be run by the menu Manual Control (Manual Control --> Reset Functions) or by DMX commands.

Tilt then Pan - the item will reset pan and tilt sequentially, first tilt, then set tilt to DMX 128 and reset pan.

Pan then Tilt - the item will reset pan and tilt sequentially, first pan, then set pan to DMX 128 and reset tilt.

Pan/Tilt EMS - Built-in electronic motion stabilizer ensures precise position of the fixture's head during its movement and also reducing its swinging when the truss shakes.

Follow Spot Mode - If the function is activated, the pan/tilt motors perform on lower power and the head position can be controlled manually. You can choose from three levels of the pan/tilt "consistency": soft, medium and hard. Note: reset of pan/tilt will not be executed if the fixture is in the Follow Spot Mode.

Microphone Sensitivity - Enter the menu if you want to adjust the microphone sensitivity from 1 (max.) to 20 (min.).

Blackout Settings - Use the menu if you need to close the light output under certain conditions which are described below

Blackout During MC - Blackout during movement correction. Set this option On if you wish to close light output during the time when the head goes to its correct position from which has been changed by an external force.

Active Blackouts - Use this menu if you wish to close the light output during effect changes.

Pan/Tilt Moving - The menu item enables to close light output while the pan/tilt DMX values are changing.

Colour Wheel Moving - The menu item enables to close light output while colour wheel is moving.

Gobo Wheel Moving - The menu item enables to close light output while the gobo wheel is moving.

Frequency Setup - The function allows you to set the PWM (Pulse Width Modulation) output frequency of LEDs to 300Hz, 600Hz, 1200Hz or 2400Hz.

Frequency Adjust - The menu item allows you fine adjustment of the LED frequency around selected frequency.

Init Effect Positions - Use the menu to set all effects to the desired positions at which they will stay after switching the fixture on without DMX signal received.

Screen Settings - Use this menu to change the touch screen settings.

Display Intensity - The item allows to control the intensity of the screen (1-min., 10-max.).

Screen saver Delay - The item allows you to keep the screen on or to turn it off automatically after 1-10 minutes after last touch (or pressing any button on the control panel).

Touchscreen Lock - The item allows you to lock the screen after last touch (or pressing any button on the control panel). The time delay can be set in range of 1-10 minutes. To unlock the screen, press the [ENTER/Display On] button.

Recalibrate Touchscreen - The item starts calibration of the touch screen. Follow the instructions on the screen.

Display Orientation - The menu allows to change display orientation.

Normal - Standard display orientation if the fixture is placed horizontally (e.g. on the ground).

Inverted - Inverted orientation (needed if the fixture is hanging on the truss).

Auto - The option activates a gravitation sensor for automatic screen orientation.

Note: **Auto** option is set as default. You change the display orientation by touching the icon  on the display, and the option set in the "Display Orientation" menu is temporarily overridden.

Temperature unit - Use the menu item to change temperature unit from °C to °F.

Fan Settings - Use the menu to set fans operation mode.

Fan Mode - Use the menu to set the fixture fans to max. power mode (option "**High**") or to the auto-control mode (option "**Auto**"). The option "**Quiet**" allows you to set desired fan noise.

The light output of the fixture is reduced at low speeds of fans. Last option "**Super Quiet**" provides extremely quiet operation of the fixture.

Quiet - Blackout Fan Off - The menu item allows you to stop all fans in the fixture (option "**On**") when its light output is closed (shutter in range of 0-31 DMX or dimmer in 0 DMX) in Quiet or Super Quiet mode.

Dimmer Curve - Use the menu to select desired dimmer curve: **Linear**, **Square Law** or **Super Square Law**.

Date & Time Settings - Use this menu to set current date and time for the fixture log system (menu "View Logs"). Set this menu items before first fixture operation.

Default Settings - The menu item allows to set all fixture parameters in this menu to the default (factory) values except items "DMX Input".

Password Protection - allows to enter password in order to prevent unauthorized person from changing setting of the fixture. Password is set to 7623 and cannot be changed.

Reset Web Password - The menu item allows you to reset a password for access to the Robe Ethernet Access Portal (REAP), default password: 2479, user: robe.

7.4 Tab "Manual Control"



Reset Functions - The menu allows to reset the fixture either per function modules or all modules together.

Total System Reset - The item resets all function modules including pan/tilt.

Pan/Tilt Reset - The item resets a pan and a tilt.

System Reset w/o P/T - The item resets all function modules except pan/tilt

Pan Reset - The item resets a pan.

Tilt Reset - The item resets a tilt.

Colour System Reset - The item resets a colour wheel 1/colour wheel 2 and CMY+CTO system.

Optics/Frost Res. - The item resets a zoom and a frost module.

Barndoors/Scrim Reset - The item resets barndoors and a scrim module..

Manual Effect control - Use the menu to control all fixture channels by means of the control panel.

7.5 Tab "Stand-alone"



Test Sequences -Use the menu to run a test/demo sequences without an external controller, which will show you some possibilities of using Robin Forte Fresnel/Forte PC.

Dynamic Mode - This mode uses all Robin Forte Fresnel/Forte PC functions including pan/tilt movement and therefore is good for a complete introduction of the fixture.

Static Mode - This mode is suitable for projections on the wall, ceiling or ground without any pan/tilt movement. Adjust the pan, tilt, zoom and focus to desired positions and start test sequences by touching the green ► icon.

Music Trigger - Use the item to activate the sound control of the running program via the built-in microphone.

Preset Playback - This menu allows you to select the program which will be played in a loop after switching the fixture on (the option is commonly used in a stand-alone operation without an external controller).

None - The option disables "Presetting playback" function.

Test - The option starts the test sequences.

Prog. 1 - The option starts user program No. 1.

Prog. 2 - The option starts user program No. 2.

Play program - Use the menu to run desired program in a loop.

Play Program 1 - The option starts user program No.1.

Play Program 2 - The option starts user program No. 2.

Edit Program - Use the menu to create or to edit desired program. The Robin Forte Fresnel/Forte PC offers 2 free programs, each up to 80 steps.

Edit Program 1 - The option allows you to edit user program No.1.

Edit Program 2 - The option allows you to edit user program No.2.

To edit program:

1. Touch the item which you want to edit ("Edit Program 1" - "Edit Program 2").
2. Touch the item "Edit Program Steps".
3. Touch the item "Step 1".
4. From the list of effects touch desired effect and set its value. Browse through the list by touching the [up arrow] and [down arrow] and set all desired effects.
An item "Step Time" (value of 0-25.5 sec.) is the time during which effects last in the current step
5. Save adjusted effects to the current step by touching the [confirm] or save and copy them to the following step by touching the [confirm+copy]. By touching the text box "Preview" next to the current program step you can view created scene.
6. Repeat the steps 4 and 5 for next program steps.
7. After editing desired program steps, adjust the length of the program by touching the text boxes "Start Step" and "End Step".

Meaning of the icons used in the "Edit Program" menu:

⬇️ - moves down on the next page ✓ - saves adjusted values and leaves menu

↓ - moves up on the previous page

✓ - saves values to the current step and copy them to the following prog. step

✗ - leaves menu without saving values

7.6 Tab "Service"



Adjust DMX Values - The menu allows you to set all effects to desired positions before fine calibration of the effects .

Calibrations - This menu enables fine calibration of fixture effects and download default calibration values.

Calibrate Effects - The menu allows the fine adjustment of effects.

Pan- a pan position fine adjustment (value range: 0-255)

Tilt - a tilt position fine adjustment (value range: 0-255)

Colour Wheel 1 - a colour wheel 1 fine movement (value range: 0-255)

Colour Wheel 2 - a colour wheel 2 fine movement (value range: 0-255)

Zoom - a zoom module fine movement (value range: 0-255)

Focus - a focus module fine movement (value range: 0-255)

Frost 1/1 - a light frost fine position movement 1

Frost 1/2 - a light frost fine position movement 2

Frost 2/1 - a medium frost fine position movement 1

Frost 2/2 - a medium frost fine position movement 2

Barndoors rot. - a fine rotation of the barndoors module (value range: 0-255)

Barndoor 1 move - a fine movement of the barndoor 1 (value range: 0-255)

Barndoor 2 move - a fine movement of the barndoor 2 (value range: 0-255)

Barndoor 3 move - a fine movement of the barndoor 3 (value range: 0-255)

Barndoor 4 move - a fine movement of the barndoor 4 (value range: 0-255)

Scrim positioning - a fine positioning of the scrim (value range: 0-255)

Scrim indexing - a fine rotation of the scrim (value range: 0-255)

Calibration of the effects via the control board

1. Disconnect DMX controller from the fixture and enter the "Calibrate Effects" menu.
2. Use the [up arrow] and [down arrow] to find "Pan" and touch it to enter the fine effect adjustment screen.
3. Set desired value and save it by touching the [confirm].
4. Repeat steps 2 and 3 for next item
5. After calibrating all effects, touch the [confirm] to save all adjusted values and reset the fixture.

Calibration of the effects via the DMX controller

1. Connect DMX controller to the fixture and enter the "Calibrate Effects" menu.

Calibration protocol:

Effect	Channel
Pan	channel 36
Tilt	channel 37
Colour wheel 1	channel 38
Colour wheel 2	channel 39
Zoom	channel 40
Focus	channel 41
Frost 1/1	channel 43
Frost 1/2	channel 44
Frost 2/1	channel 45
Frost 2/2	channel 46
Barndoors rotation	channel 47
Barndoor 1 move	channel 48
Barndoor 2 move	channel 49
Barndoor 3 move	channel 50
Barndoor 4 move	channel 51
Scrim positioning	channel 52
Scrim indexing	channel 53

Calibrate Pan/Tilt EMS - This menu item allows calibration of the pan/tilt electronic motion stabilizer. Important: during this calibration any external force must not influence the fixture and the surface at which the fixture stands (or truss if the fixture hangs) has to be without movement, shake, strokes etc.

Load Default Calibrations - The item loads default (factory) calibration values.

LEDs Measure - This menu item runs a procedure which measures a light intensity of the LEDs module installed in the fixture. This procedure takes about 1 minute (message "LEDs Module Measurement" is displayed on the screen). During the procedure the fixture does not receive DMX signal, pan/tilt go to 128 DMX, a shutter is open and a dimmer is set at max. light intensity (255 DMX). All effects are taken out from the light beam.

The measured light intensity is recorded in the item Intensity in the menu LED Module Info:

Tab Information --> Actual Module Info --> Intensity

Tab Information --> Intensity History --> Intensity

The light intensity in the menu item Intensity is displayed in percentages in relation to the initial intensity of the new LEDs module (initial intensity=100%).

The LEDs Measure procedure should be run after every change of the LED light source.

Note: The fixture has to be connected to mains in order to run LEDs Measure procedure.

Update software - The menu item allows you to update software in the fixture.

The following items are required in order to update software:

- PC running Windows or Linux or macOS
- DSU file
- Flash cable RS232/DMX, P/N13050624 (if you want to use a serial port of PC)
- Robe Universal Interface or Robe Universal interface WTX (if you want to use an USB port of PC)

After the software updating the fixture will be set to default values.

To update software in the fixture:

1. DSU file is available from Robe web site at WWW.robe.cz.

File with extension zip is intended for Windows (used and tested from XP to W10 on 32/64bit systems).

File with extension tbz is intended for Linux (used and tested on Debian and Ubuntu 32/64bit).

File with extension dmg is intended for macOS (used and tested on OSX up to Sierra) XQuartz required, install it from <https://www.xquartz.org/>

Save the download file to a folder on your computer.

In case that you use windows, extract files in the zip file (e.g. DSU_RobinForte_Wash_18100828.zip)

2. Disconnect the fixture from DMX controller.

3. If you use the flash cable RS232/DMX, connect a serial port of your computer with DMX input of the fixture by means of the cable.

If you use the Robe Universal Interface, connect a USB port of your computer with the Robe Universal Interface by means of the USB cable and DMX input of the fixture with the DMX output of the Robe Universal Interface via a DMX cable.

4. Switch the fixture to the update mode (tab "Service" --> Update Software).

Note: If you do not want to continue in the software update, you have to switch off and on the fixture to escape from the updating mode.

We recommend to cancel all running programs on your computer before starting the software update.

5. Double-click the software uploader file (e.g. DSU_RobinForte_Wash_18100828.exe) in the extracted files. The Software Uploader program will start to run.

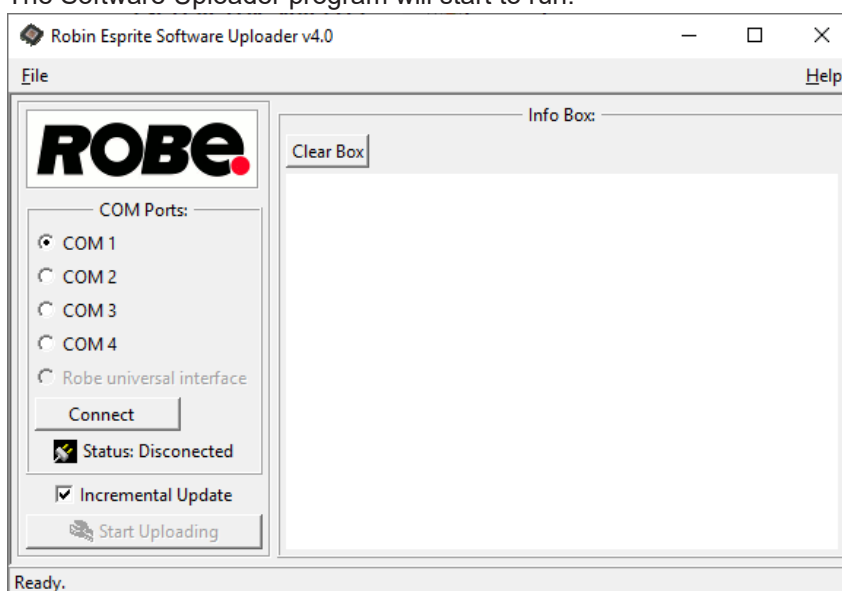

6. Select correct "COM " number if you use a Flash cable RS232/DMX or select "Robe Universal Interface " if you use the Robe Universal Interface/Robe Universal Interface WTX and then click on the "Connect" button.
7. If the connection is OK, click the "Start Uploading" button to start software uploading. It will take several minutes to perform software update.
 If the option "Incremental Update" is not checked, all processors will be updated (including processors with the same software version).
 If you wish to update only processors with new version of software, check the "Incremental Update box".
 Avoid interrupting the process. Update status is being displayed in the "Info Box" window.
 When the update is finished, the line with the text "Fixture is successfully updated" will appear in this window.
 In case upload process is interrupted (e.g. power loss), the fixture stays in "Updating mode" and you will have to repeat the software update again.
 Another way, how to update software in the fixtures (especially large installation of fixtures) is to use the ROBE Uploader. It is a software for automatized software update of Robe fixtures. It takes advantage of RDM support).
 For more information please see <https://www.robe.cz/robe-uploader/>.

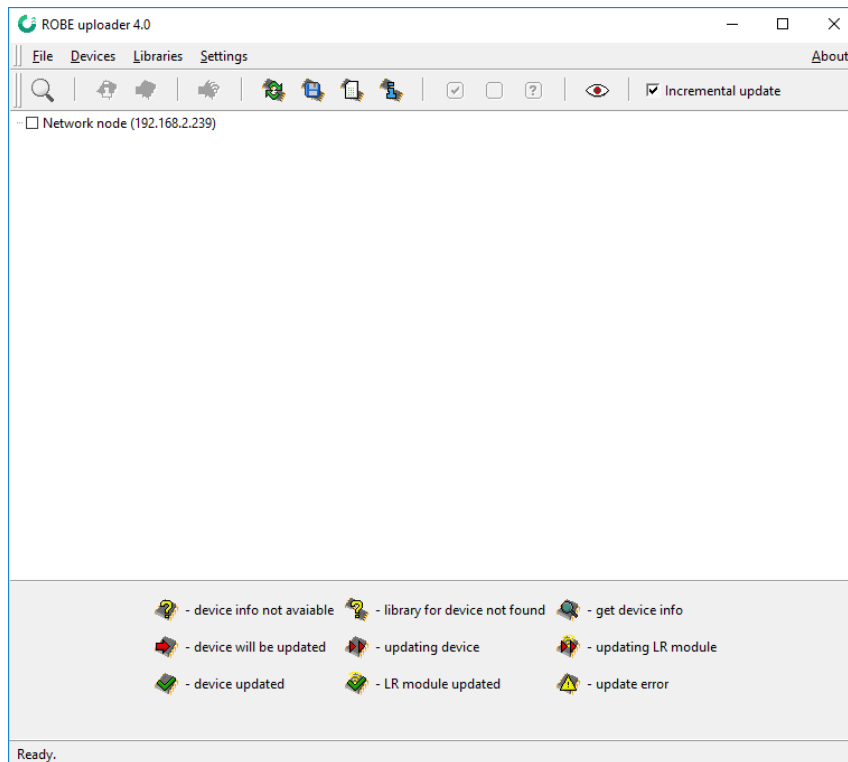

8. RDM

This fixture supports RDM operation. RDM (Remote Device Management) is a bi-directional communications protocol for use in DMX512 control systems, it is the new open standard for DMX512 device configuration and status monitoring.

The RDM protocol allows data packets to be inserted into a DMX512 data stream without adversely affecting existing non-RDM equipment. By using a special „Start Code,“ and by complying with the timing specifications for DMX512, the RDM protocol allows a console or dedicated RDM controller to send commands to and receive messages from specific moving lights.

RDM allows explicit commands to be sent to a device and responses to be received from it.

The list of commands for Robin Forte Fresnel/Forte PC is the following:

Parameter ID	Discovery command	SET command	GET command
DISC_UNIQUE_BRANCH	*		
DISC_MUTE	*		
DISC_UN_MUTE	*		
DEVICE_INFO			*
SUPPORTED_PARAMETERS			*
SOFTWARE_VERSION_LABEL			*
DMX_START_ADDRESS		*	*
IDENTIFY_DEVICE		*	*
DEVICE_MODEL_DESCRIPTION			*
MANUFACTURER_LABEL			*
DEVICE_LABEL		*	*
SENSOR_DEFINITION			*
SENSOR_VALUE			*
DISPLAY_INVERT		*	*
DISPLAY_LEVEL		*	*
PAN_INVERT		*	*
TILT_INVERT		*	*
DEVICE_RESET		*	
DMX_PERSONALITY		*	*
DMX_PERSONALITY_DESCRIPTION			*
STATUS_MESSAGES			*
STATUS_ID_DESCRIPTION			*

RDM model ID for the Robin Forte Fresnel/Forte PC is 0x013e.

If you need to set RDMnet scope, use the ROBE Ethernet Acces Portal (REAP) and menu Personality-->-->Ethernet Settings.

The screenshot shows the 'Ethernet settings' window in the IPainte application. The window title is 'Ethernet settings' with a close button. Below the title bar, there are several configuration sections:

- Ethernet mode:** Radio buttons for 'disable' (selected), 'ArtNet', 'gMA1', 'gMA2', and 'sACN'.
- Ethernet to DMX:** Radio buttons for 'off' (selected) and 'on'.
- ArtNet universe:** A text input field containing '0'.
- MANet I/II universe:** A text input field containing '1'.
- MANet session ID:** A text input field containing '1'.
- sACN universe:** A text input field containing '1'.
- RDMnet scope:** A text input field containing 'default', which is highlighted with a red rectangular box.

At the bottom right of the settings window, there is a blue 'Save' button.

9. Robe Ethernet Access Portal (REAP)

The REAP allows you to display on your computer information about some fixture settings, operating conditions (e.g. temperature in the fixture) and error messages which were generated during fixture operation. Your computer needs to be connected to the fixture(s) through the means of Ethernet wired network and a network switch.

The Ethernet network connection (Local LAN) typically needs to be set to 2.x.x.x address, assuming that no other computer on the network contains such an address while keeping all ROBE fixtures in default IP settings.

For more information about REAP options, computer and fixture settings please see the REAP user manual at https://www.robe.cz/res/downloads/user_manuals/User_manual_REAP.pdf.

10. Error and information messages

Information icon



- Air Filters Cleaning

This icon signals that cleaning period of the air filters has elapsed and you have to clear air filters and reset the menu item "Elapsed Time".

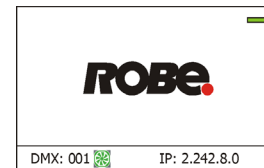

Errors

Error in the fixture is signalled by the yellow warning icon at the bottom line of the screen:

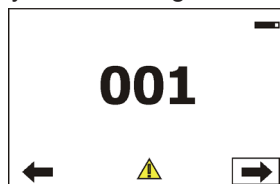

Touch the warning icon or press the [ESCAPE] button to display error messages.
List of error and information messages:

Pan Error 1

Pan sensor is not in a function state "connected".

Pan Error 2

Pan sensor is not in a function state "unconnected".

Pan Error 3

Pan feedback error.

Tilt Error 1

Tilt sensor is not in a function state "connected".

Tilt Error 2

Tilt sensor is not in a function state "unconnected".

Tilt Error 3

Tilt feedback error.

Colour Wheel 1 Error 1

Magnetic/optic sensor was not detected.

Colour Wheel 1 Error 2

Magnetic/optic sensor permanently detects colour wheel 1.

Colour Wheel 2 Error 1

Magnetic/optic sensor was not detected.

Colour Wheel 2 Error 2

Magnetic/optic sensor permanently detects colour wheel 2.

Frost Error 1

Impact to the mechanical end of the frost 1 track (frost 2 track) was not detected.

Frost Error 4

Incorrect detection of a frost 1 track (frost 2 track). Impact to a mechanical obstruction was detected within running of the frost.

Zoom Error 1

Impact to the mechanical end of the zoom track was not detected.

Zoom Error 4

Incorrect detection of a zoom track. Impact to a mechanical obstruction was detected within running of the zoom.

Scrim Rotation Error 1

Magnetic/optic sensor was not detected.

Scrim Rotation Error 2

Magnetic/optic sensor permanently detects scrim.

Scrim Index Error 1

Impact to the mechanical end of the scrim was not detected.

Scrim Index Error 4

Incorrect detection of the scrim. Impact to a mechanical obstruction was detected within running of the scrim.

BD. Rotation Error 1

Impact to the mechanical end of the barn doors wheel was not detected.

BD. Rotation Error 2

Incorrect detection of the barn doors wheel. Impact to a mechanical obstruction was detected within running of the barn doors wheel.

BD. 1 Error 1

Impact to the mechanical end of the barn door 1 was not detected.

BD. 1 Error 4

Incorrect detection of the barn door 1. Impact to a mechanical obstruction was detected within running of the barn door 1.

BD. 2 Error 1

Impact to the mechanical end of the barn door 2 was not detected.

BD. 2 Error 4

Incorrect detection of the barn door 2. Impact to a mechanical obstruction was detected within running of the f barn door 2.

BD. 3 Error 1

Impact to the mechanical end of the barn door 3 was not detected.

BD. 3 Error 4

Incorrect detection of the barn door 3. Impact to a mechanical obstruction was detected within running of the barn door 3.

BD. 4 Error 1

Impact to the mechanical end of the barn door 4 was not detected.

BD. 4 Error 4

Incorrect detection of the barn door 4. Impact to a mechanical obstruction was detected within running of the barn door 4.

EEProm Error

Hardware error of the EEPROM.

Recharge The battery

The battery on the display board needs to be charged. Let the fixture on for cca 6 hrs.

Battery Faulty. Replace it.

The battery on the display board is exhausted and should be replaced immediately.

Pan/Tilt EMS Cal. Error

The EMS system is not calibrated.

Pan/Tilt EMS Error

Control electronics cannot communicate with the EMS system.

Internal Error 1

Communication error between PCBs (error or noise was detected on communication wires)

Internal Error 2

Communication error (some PCB has failed or is disconnected (this PCB will show as N/A in menu --> Information --> Software versions) or error/noise was detected on communication wires)

Clean Air Filters

The message informs you that the item "Elapsed Time" in the "Fixture Information" menu is at 0 value. Clean air filters and reset this counter.

Overheated

The LED engine is overheated and light output is closed.

White 1 Short Error (White 2 Short Error/ White 3 Short Error/ White 4 Short Error)

Some white LEDs in the light source have short circuit.

White 5 Short Error (White 6 Short Error/ White 7 Short Error/ White 8 Short Error)

Some white LEDs in the light source are disconnected.

Base Fan 1 Bad/ Base Fan 2 Bad

One or both fans in the fixture base are disconnected from their control PCB or are faulty and has to be replaced. .

Suction LED Fan 1 Bad/ Suction LED Fan 2 Bad/ Suction LED Fan 3 Bad

The suction fan 1 (fan 2/ fan 3) at the LED engine is disconnected from its control PCB or is faulty and has to be replaced.

Exhaust LED Fan 1 Bad/ Exhaust LED Fan 2 Bad/ Exhaust LED Fan 3 Bad

The exhaust fan 1 (fan 2, fan 3) at the LED engine is is disconnected from its control PCB or is faulty and should be replaced.

Arm Fan Bad

The fan which cools the PCB in the fixture head is disconnected from its control PCB or is faulty and should be replaced. A light output from the fixture is closed.

Positions of cooling fans and their control PCBs:

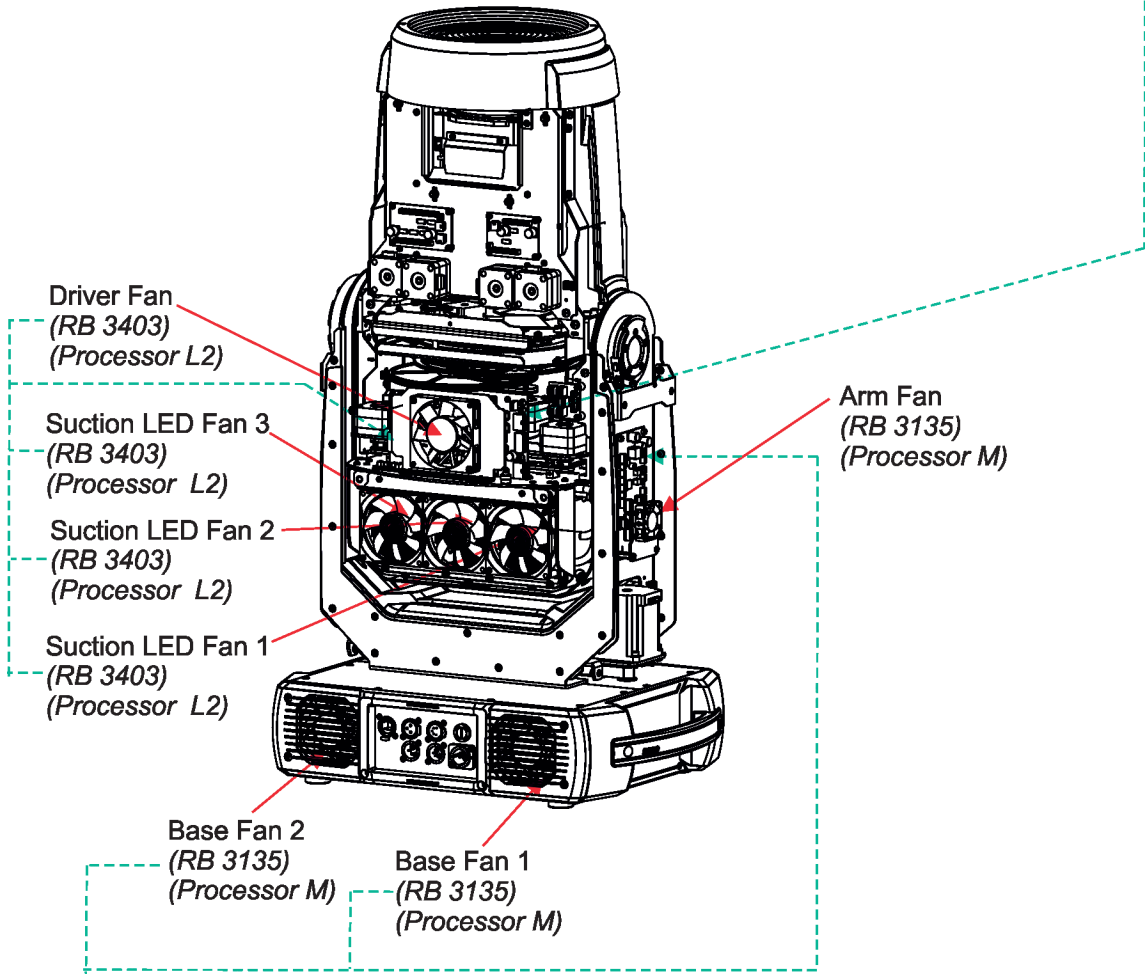
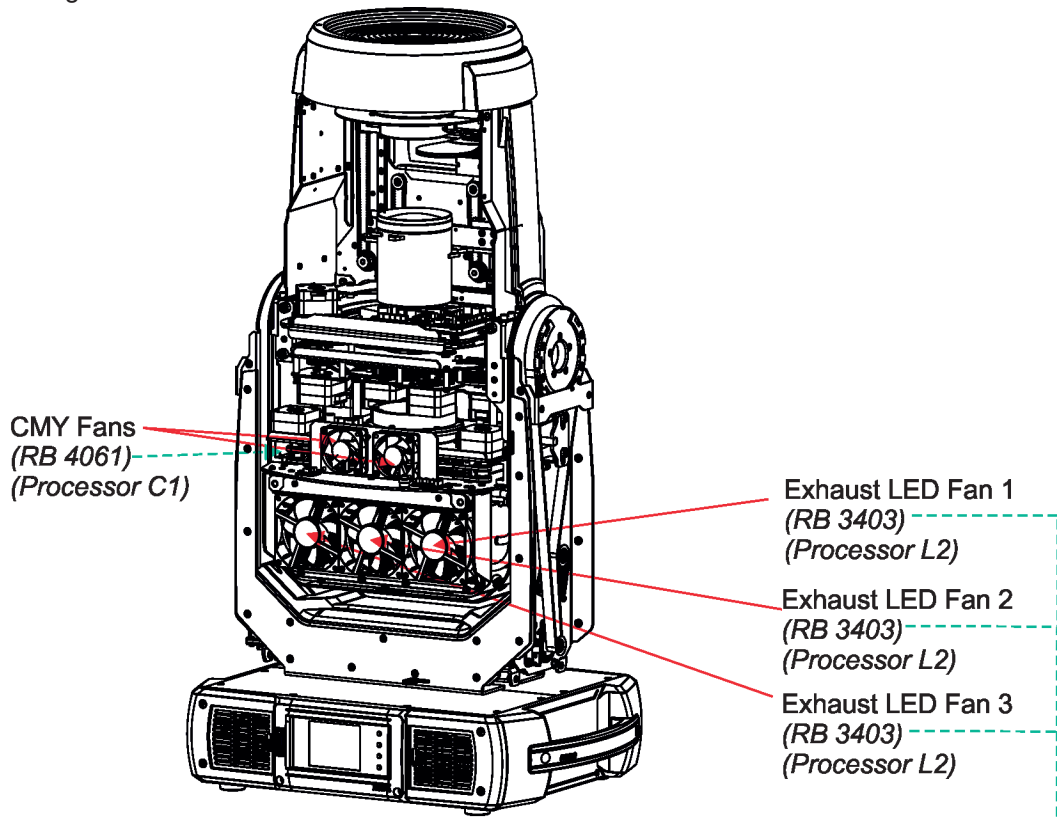

11. NFC

The fixture supports NFC. Using the mobile phone application ROBE COM you can read and set the Robin Forte Fresnel/Forte PC parameters (DMX address, IP address...etc.), get information about temperatures, operation hours, RDM identification etc.

The NFC point is situated on the side of the fixture base:

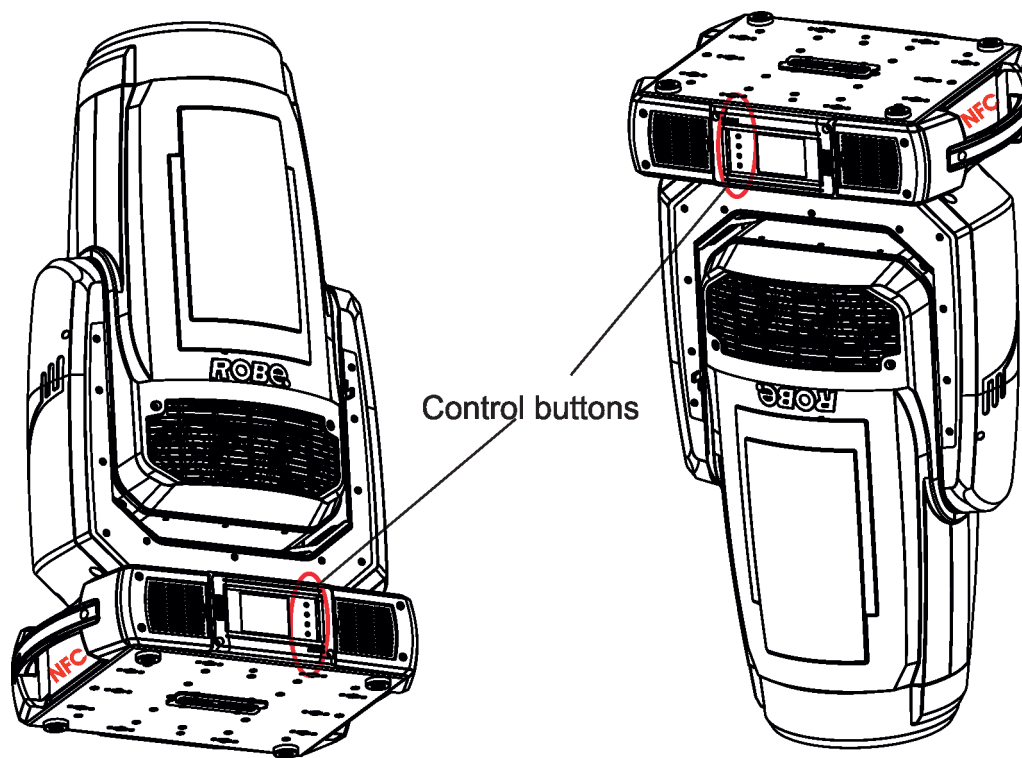

Download and install the ROBE COM from Google Play (for Android 5.0 and higher) or App Store (for iOS 12.0 and higher) to your mobile phone. Your mobile phone has to support NFC (Near-Field Communication).

Hold the mobile phone on the side of the fixture base, if NFC connection is OK, discovered fixture will appear on the screen, after touching the fixture name the following the following menu items will appear:

- DMX/RDM settings
- Ethernet settings
- Blackout settings
- Colour settings
- Display settings
- Standalone settings
- Pan/Tilt settings
- Other settings
- Software versions
- Device hours
- Device temperatures

Touch desired menu item to enter its submenu.

12. Technical Specifications

Electrical

Power supply: electronic auto-ranging
Input voltage range: 100-240V, 50-60Hz
Fuse: T 15 A
Max. power consumption: 1250W (Power factor 0.98)

Optic

Light source: TE™ 1.000W XP White LED Engine (Transferable)
Colour temperature: 6700K
CRI: 70/80/90, remotely selectable
Light source warranty: 4 years or 20 000 hours

Light source type: TE™ 1.000W HCF White LED Engine (Patented)
Colour temperature: 6000K
CRI:96
Light source warranty: 4 years or 20 000 hours

Colour wheel 1

five dichroic filters (deep red, deep blue, orange, green, congo blue) + open

Colour wheel 2

five dichroic filters (multicolour filter, laser green, lavender, CRI filter 80, CRI filter 90)
+ open

CMY + CTO mixing module

Smooth CMY colour mixing system
Variable CTO: 3000K - 6.700K

Virtual colour wheel

66 preset colours

Frost filters

2 separate, variable frost filters (light (5°) and medium (10°))
Both filters are replaceable

Scrim

Graduated filter position control, +/- 180° module rotation (Patent pending)

Internal barndoors

Individual position control of 4 "doors",
+/- 90° module rotation

Zoom

Forte PC: 5.5° - 62°
Forte Fresnel: 6°- 61°

Strobe

Strobe effect with variable speed (0.3 - 20Hz)

Dimmer

Smooth dimmer from 0 - 100 % (8 or 16 bit (internal 18 bit))

Control

Graphic touch screen for fixture setting and addressing
Gravitation sensor for auto screen positioning

Battery backup of the touch screen
Readout fixture and LEDs usage, receiving DMX values, temperatures, etc
Built-in analyzer for easy fault finding, error messages
Built-in demo sequences
Stand-alone operation
2 user editable programs, each up to 80 steps
Supported protocols: USITT DMX 512-A, RDM, ArtNet, MANet, MANet2, sACN
Support of RDM (Remote Device Management) and NFC
1 DMX mode (35 control channels)

Wireless DMX/RDM module type RW 001 (only wireless DMX version of the fixture)

Supported protocols: full RDM support, CRMX , W-DMX™ G2, G3,G4 and G4S
Operational frequency range: 2402-2480 MHz
Output power: 100 mW
Receiver sensitivity (0.1% BER): -93 dBm
Crystal Clock Frequency : 16.0 MHz

Max. number of fixtures in Ethernet IN/Out line

8

Pan/Tilt

Pan movement range 540°
Tilt movement range 270°
16 bit movement resolution
Pan/Tilt electronic motion stabilizer
Automatic Pan/Tilt position correction
Remotely controllable speed of pan/tilt movement for easy programming
Pan/tilt-lock mechanism

Connection

DMX data in/out: 2x Locking 3-pin XLR, 2x Locking 5-pin XLR)
AC power input: Chassis connector Neutrik PowerCon TRUE 1, NAC3MPX
Ethernet In/Out: 2 x RJ 45

Rigging

Mounting points: 5 pairs of 1/4-turn locking points
Mounting horizontally or vertically via 2 Omega brackets

Temperatures

Maximum/Minimum ambient operating temperature : +45°C/-5°C
Maximum housing temperature : 80° C

Minimum distances

Min. distance from flammable surfaces: 1 m
Min. distance to lighted object: 4 m

Total heat dissipation

3200 BTU/hr (calculated)

Ingress protection rating

IP20

Weight

39.5 kg (87.08 lbs) (Forte Fresnel)
39.5 kg (87.08 lbs) (Forte PC)

Dimensions (mm)

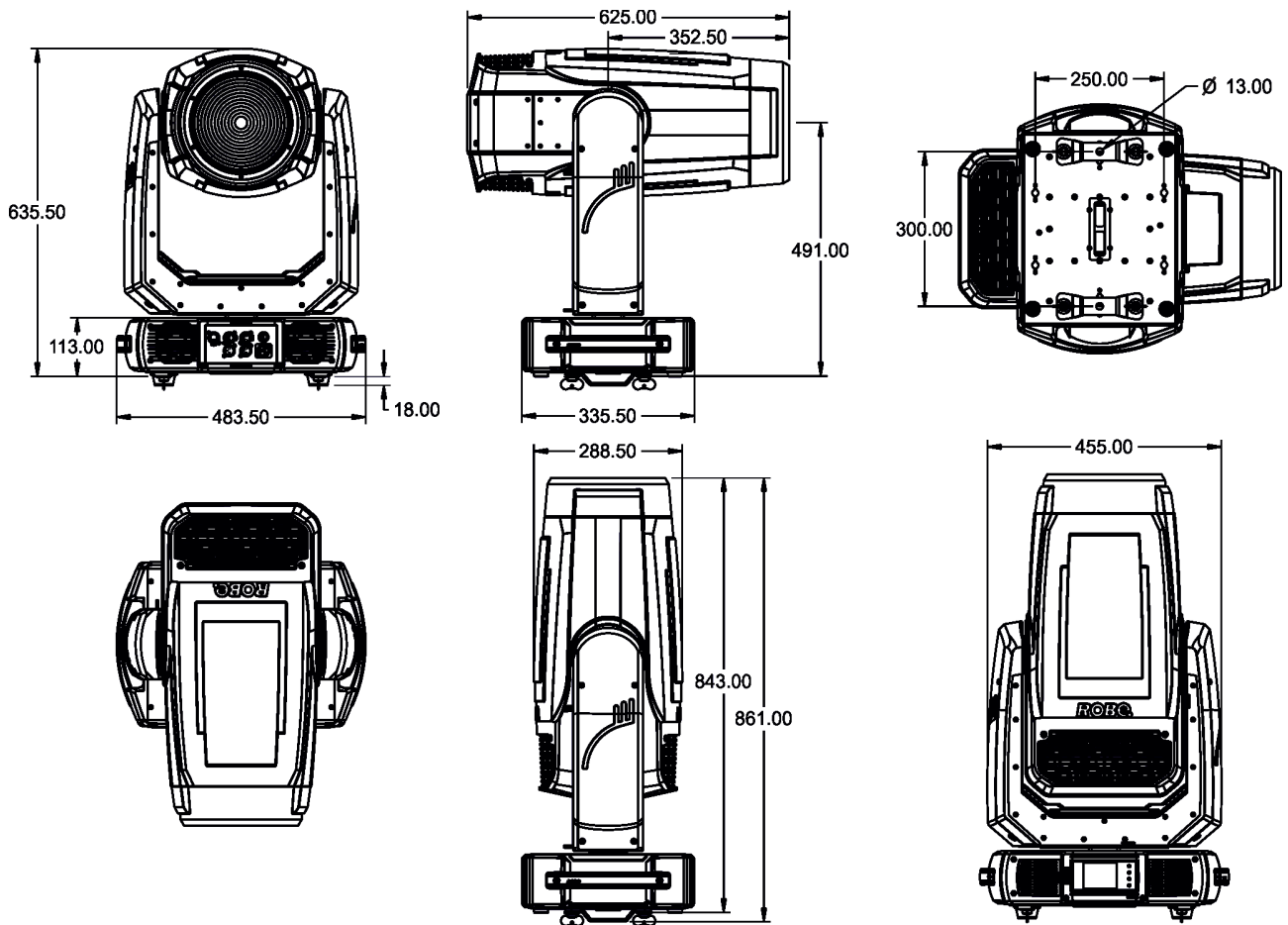

Accessories

- 1 x Omega adaptor CL-regular 2 pcs in box (P/N 10980033)
- 1 x Frame adaptor (P/N 99016721) installed on the fixture head
- 1 x Power cable including powerCON TRUE1 In connector
- 1 x Top hat (P/N 11031059-02) - Forte Fresnel only

Optional accessories

- Gel Frame (P/N 10980561)
- Frost 0,5° (exchange) for Robin T2 Profile/Forte (P/N 10980581)
- Frost 1° (exchange) for Robin T2 Profile/Forte (P/N 10980564)
- Frost 5° (exchange) for Robin T2 Profile/Forte (P/N 10980565)
- Frost 10° (exchange) for Robin T2 Profile/Forte (P/N 10980556)
- Frost 20° (exchange) for Robin T2 Profile/Forte (P/N 10980577)
- Frost 30° (exchange) for Robin T2 Profile/Forte (P/N 10980582)
- Doughty Trigger Clamp (P/N 17030386)
- Safety wire 50 kg (P/N 99011957)
- Omega Adaptor Tall CL-regular 2 pcs in box (P/N 10980501)
- Robin Forte LightMaster rear kit SET (P/N 10080335)
- Robin Forte LightMaster side kit SET (P/N 10080334)
- TE™ HP LED Engine for Forte (P/N 14080067)
- TE™ HCF LED Engine for Forte (P/N 14080072)
- TE™ HCF LED Engine for Forte in protective case (P/N 14080074)
- TE™ HP LED Engine for Forte in protective case (P/N 14080076)
- Module of Fresnel Lens for T2/Forte PC (P/N 10980610)
- Module of PC Lens for T2/Forte Fresnel (P/N 10980611)
- Upgrade kit CRMX Universal 260 (P/N 99030100)

Difference between Omega adaptor CL-regular and Omega adaptor Tall CL-regular:

Omega adaptor CL-regular (P/N 10980033)

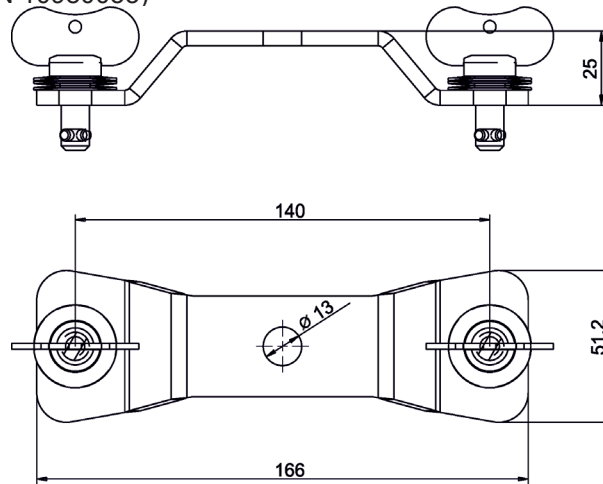

Omega adaptor Tall CL-regular (P/N 10980501)

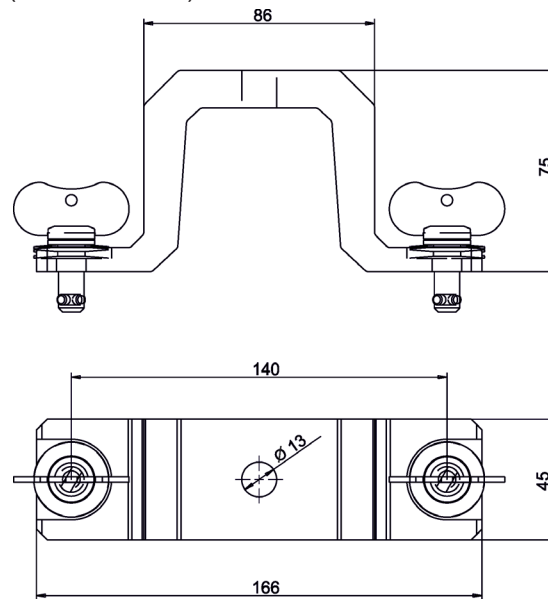

13. Maintenance and cleaning

It is absolutely essential that the fixture is kept clean and that dust, dirt and smoke-fluid residues must not build up on or within the fixture. Otherwise, the fixture's light-output will be significantly reduced. Regular cleaning will not only ensure the maximum light-output, but will also allow the fixture to function reliably throughout its life. A soft lint-free cloth moistened with any good glass cleaning fluid is recommended, under no circumstances should alcohol or solvents be used!

DANGER !
Disconnect from mains before starting any
maintenance work

The front objective lens will require weekly cleaning as smoke-fluid tends to building up residues, reducing the light-output very quickly. The cooling-fans should be cleaned monthly. The interior of the fixture should be cleaned at least annually using a vacuum-cleaner or an air-jet. Gobo wheels and the internal lenses should be cleaned monthly. Remove dust and dirt from the fans and cooling vents using a soft brush and vacuum-cleaner.

Important! Check the air filters periodically and clean before they become
clogged!

Clean two air filters placed in the fixture base. Use a vacuum cleaner, compressed air or you can wash them and put back dry.

After replacing the air filters, reset the elapsed time counter in the tab "Information" (Information--->Air Filters---> Elapsed Time).

Sliding bars of CMY colour mix. system should be lubricated every 6 months. As lubricant we recommend ARONIX silicone oil 500 cSt - it is a medium viscosity lubricant, release agent, high temperature oil (from -20°C to +300°C).

Replacing the fuse.

Before replacing the fuse, unplug mains lead.

1. Remove the fuse holder on the rear panel of the base with a fitting screwdriver from the housing (anti-clockwise).
2. Remove the old fuse from the fuse holder.
3. Install the new fuse in the fuse holder (only the same type and rating).
4. Replace the fuseholder in the housing and fix it.

Checking plastic parts of the fixture.

The plastic parts of the fixture should be checked for damages and beginning cracks at least every two months. In addition, the plastic part of the front lens has to be checked mechanically (by means of movement by the plastic part) if it is firmly fastened to the fixture. If hint of a crack is found on some plastic part, do not use the fixture until the damaged part will be replaced.

Cracks or another damages of the plastic parts can be caused by the fixture transportation or manipulation and also ageing process may influence plastic materials.

This checking is necessary for both fixed installations and preparing fixtures for renting. Any free moving parts inside of the fixture head, cracked plastic or any plastic part of front lens not sitting properly in place need to be immediately replaced.

13.1 Disposing of the product

To preserve the environment please dispose or recycle this product at the end of its life according to the local regulations and codes.

14. ChangeLog

This section summarizes changes in the user manual.

Version of the manual	Date of issue	Description of changes
1.1	16/10/2023	Fixture fans description changed
1.2	12/12/2023	RDMnet, intensity drop signalization and QR code on display
1.3	31/05/2024	Included accessories specified

May 31, 2024

Copyright © 2023-2024 Robe Lighting - All rights reserved

All Specifications subject to change without notice

Made in CZECH REPUBLIC by ROBE LIGHTING s.r.o. Palackeho 416/20 CZ 75701 Valasske Mezirici

15. Appendix

15.1 Changing the LED light source

The Robin Forte allows you to change the LED light source and this way keep a high performance of the fixture.

To change the LED light source.

1. Disconnect the fixture from mains and allow it to cool about 30 minutes.
2. Remove top covers of the fixture and lock the head in a horizontal position in which you will have access to the control PCB of the LED light source.
3. Disconnect two black connectors (2) and one white connector (1) from the LEDs control PCB.

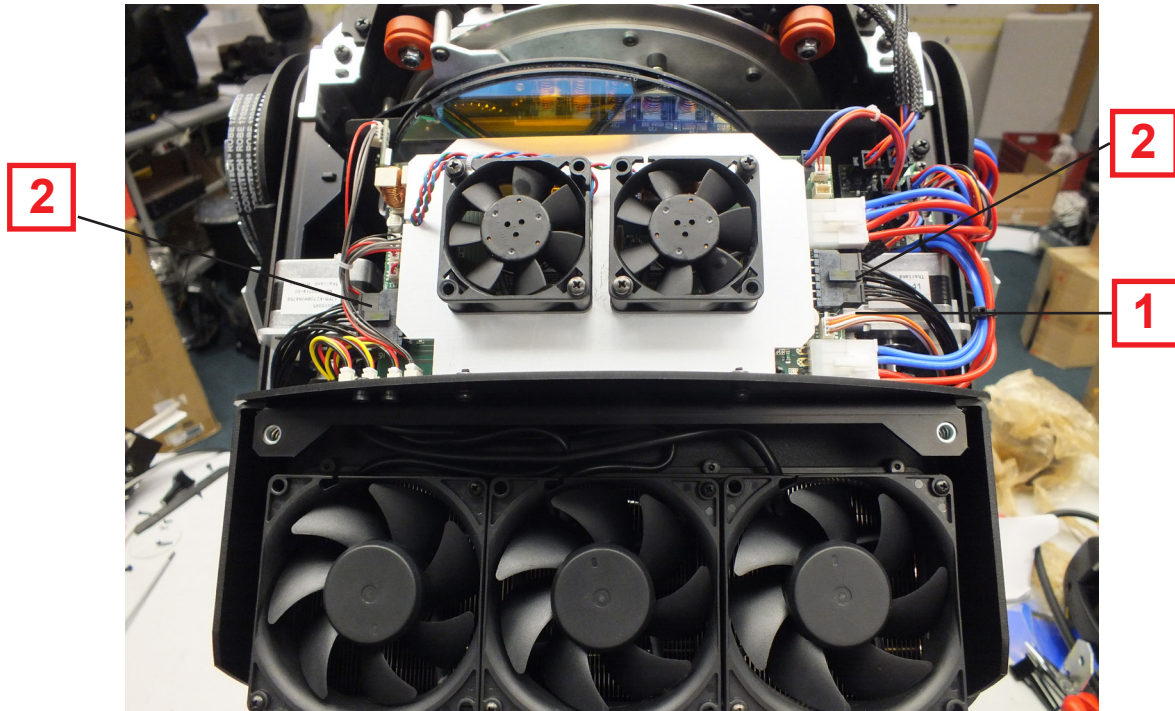

4. Unscrew two screws M3x12 with star washers (3) on each side of the rear cover (4) of the head and remove the cover (4).

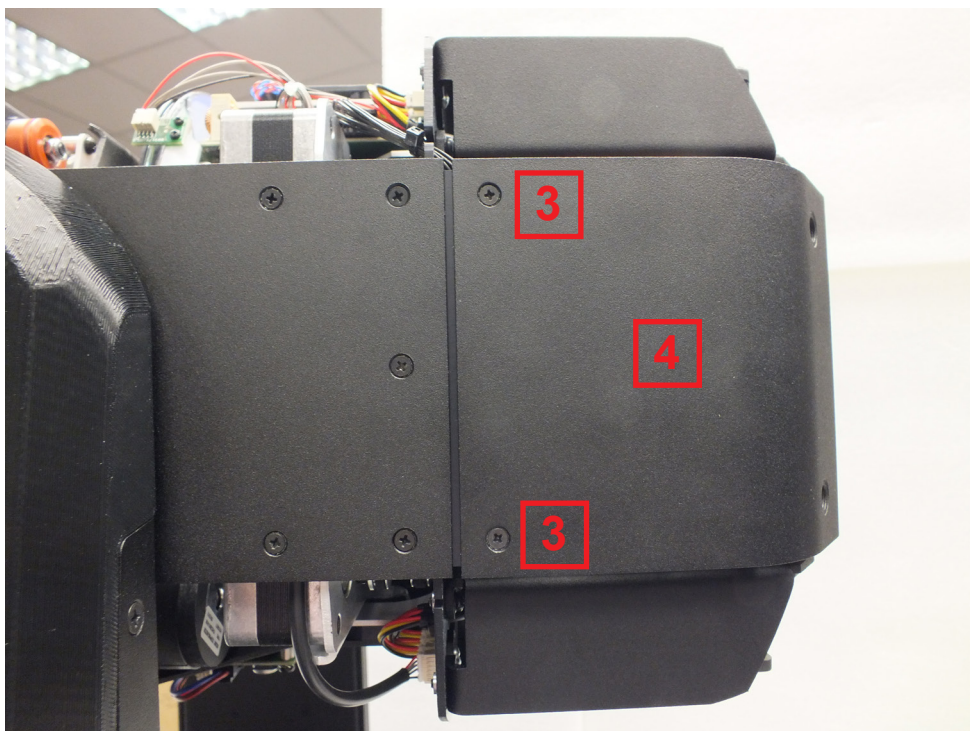

5. Unscrew the four screws M5x25 and remove the LED light source (6) from the head. Be careful, the LED light source is heavy.

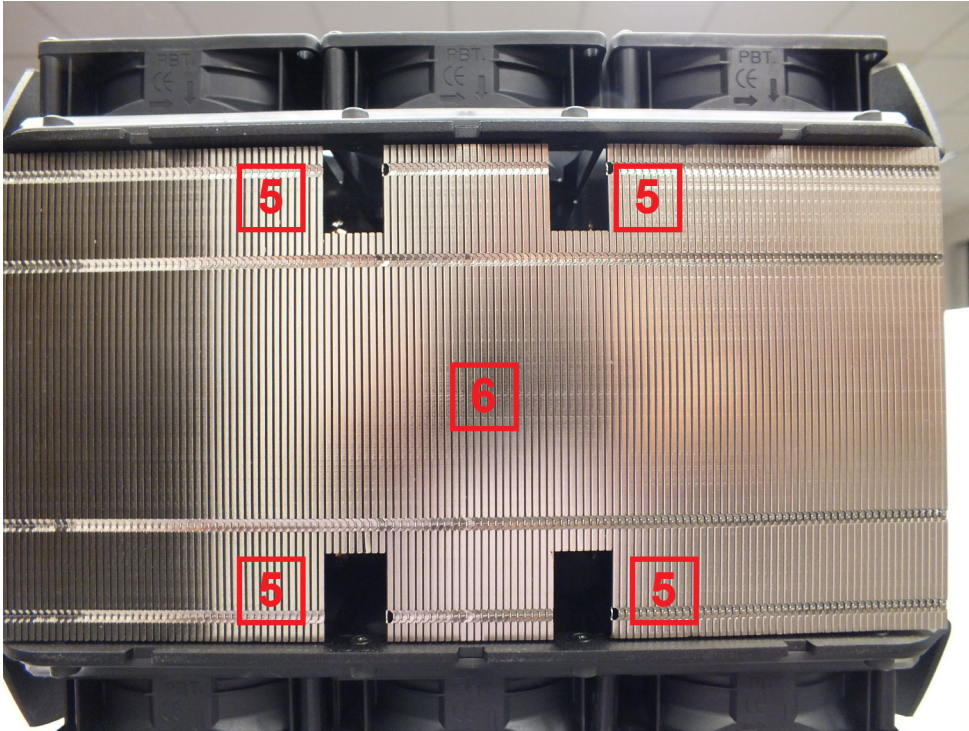

Fixture head without the LED light source.

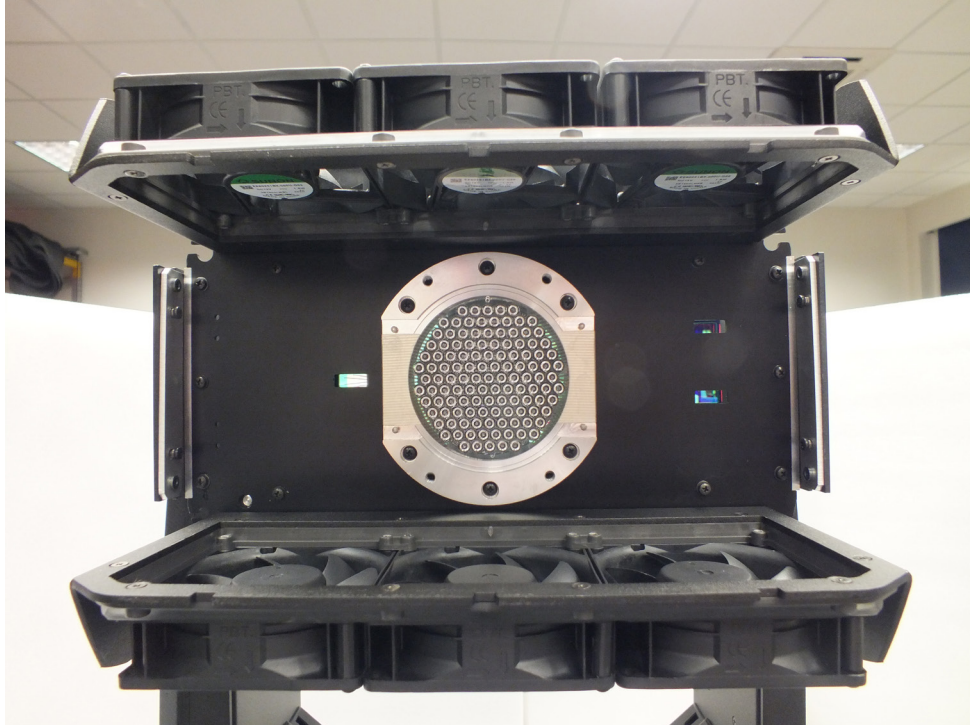

The new LED light source includes PCB with LEDs, heat sink and connecting cables with connectors. Handle with care. Do not touch LEDs with bare hands.

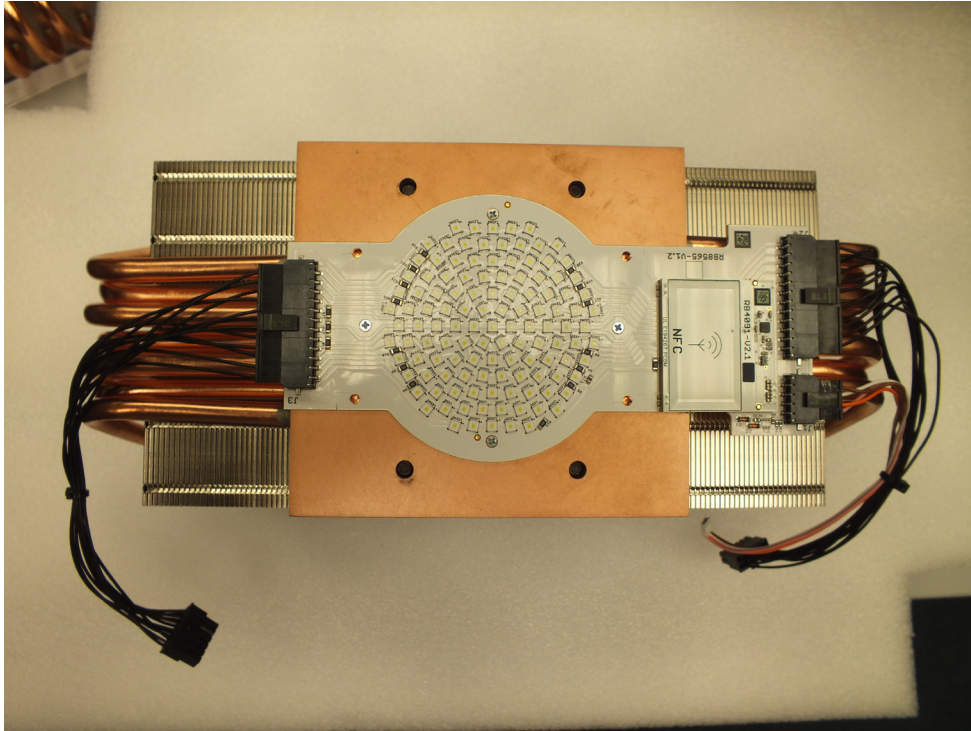

6. To install the new LED light source, proceed in a reverse order than at its dismantling, i.e. screw the LED lightsource (6) to the head, screw the rear cover (4) on the head and connect the connectors from the LED light source to the LEDs control PCB.

Placing of the LED light source cables:

Cables on both sides of the LED light source have to be inserted in the grooves (10) of the chassis.

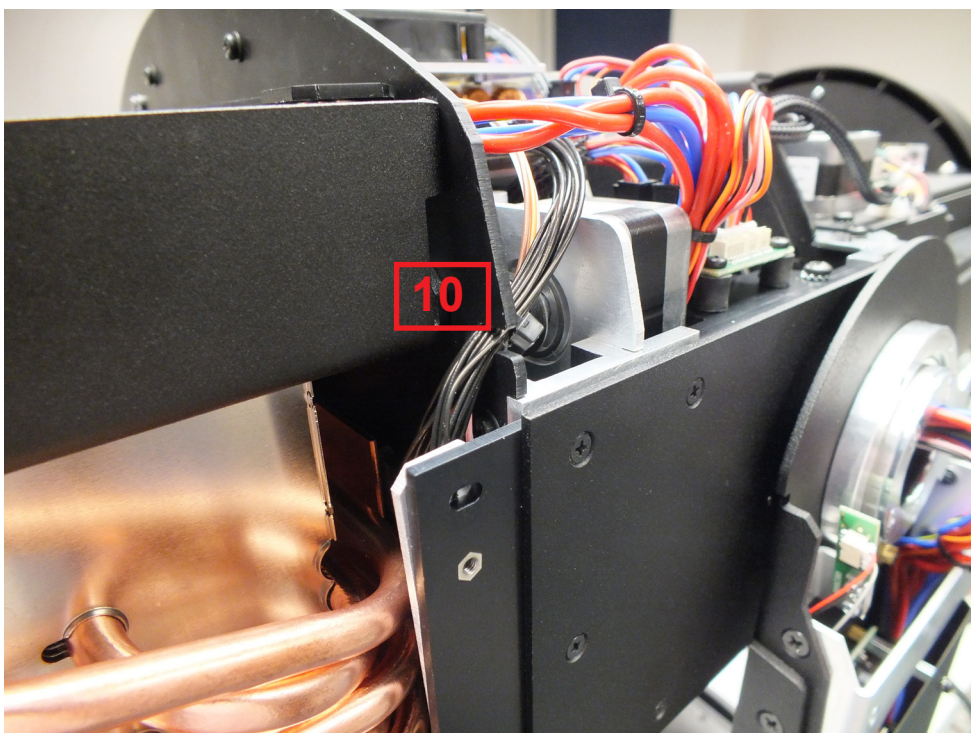

Note for mounting of the rear cover (4).

The protrusions (11) of the rear cover (4) have to be correctly placed to the openings (12) of chassis.

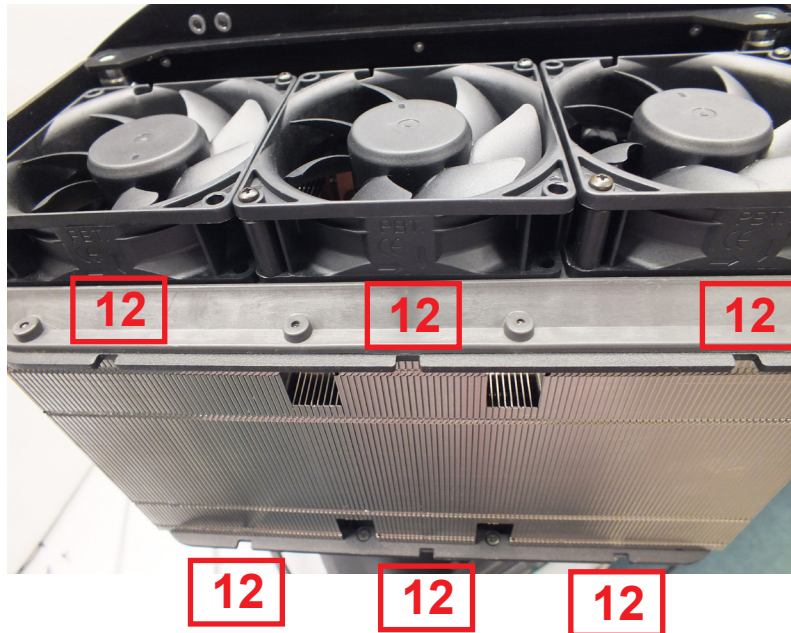
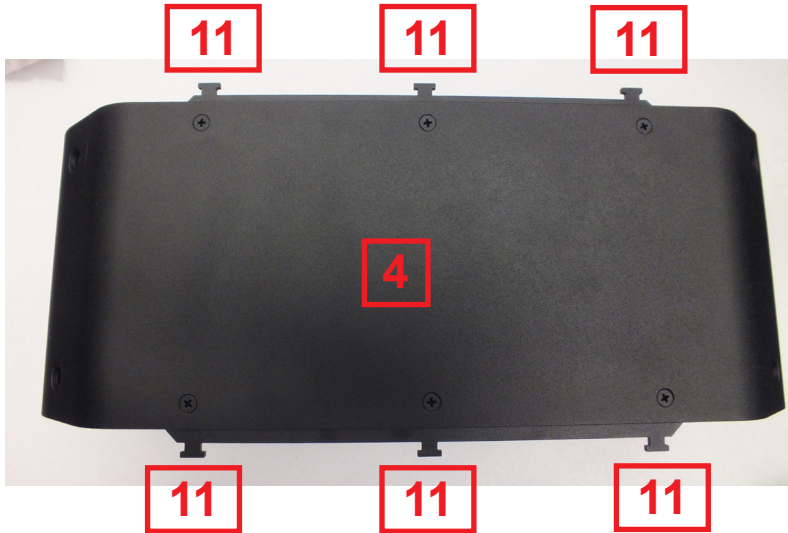

After placing the rear cover (4) on the head, do not fully tighten the screws (3) in the holes with M3 thread (7). We recommend you to install one or both plastic covers (8) on the head, check that cover (s) properly fits to the rear cover (4) and then fully tighten the rear cover screws (3).

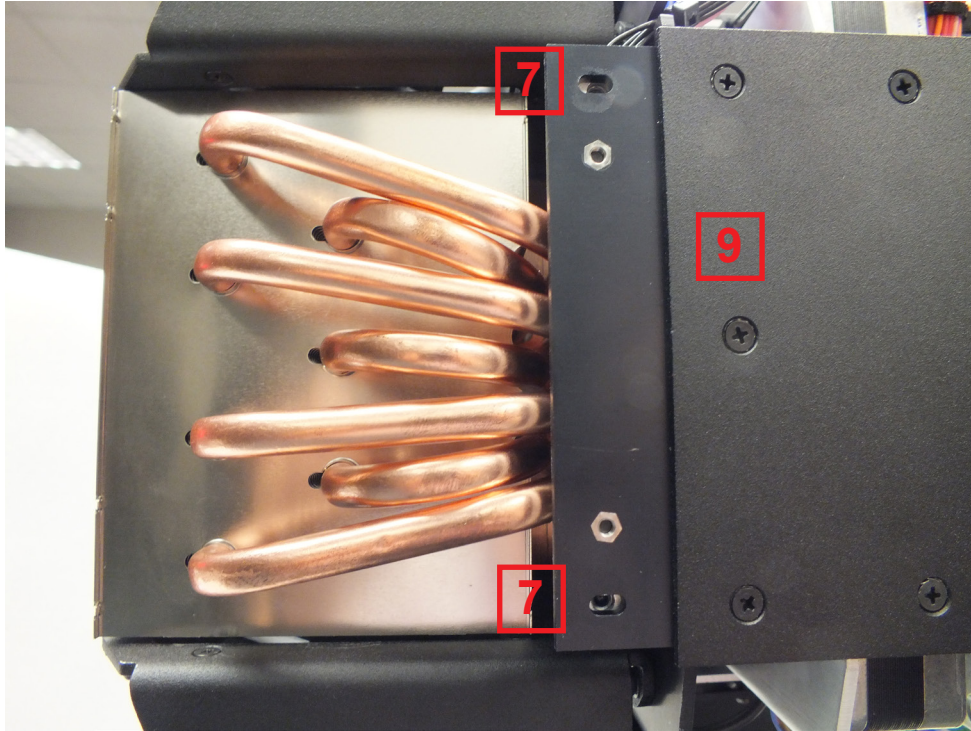

There can be a space (about 1 mm) between the rear cover (4) and the side cover (9).

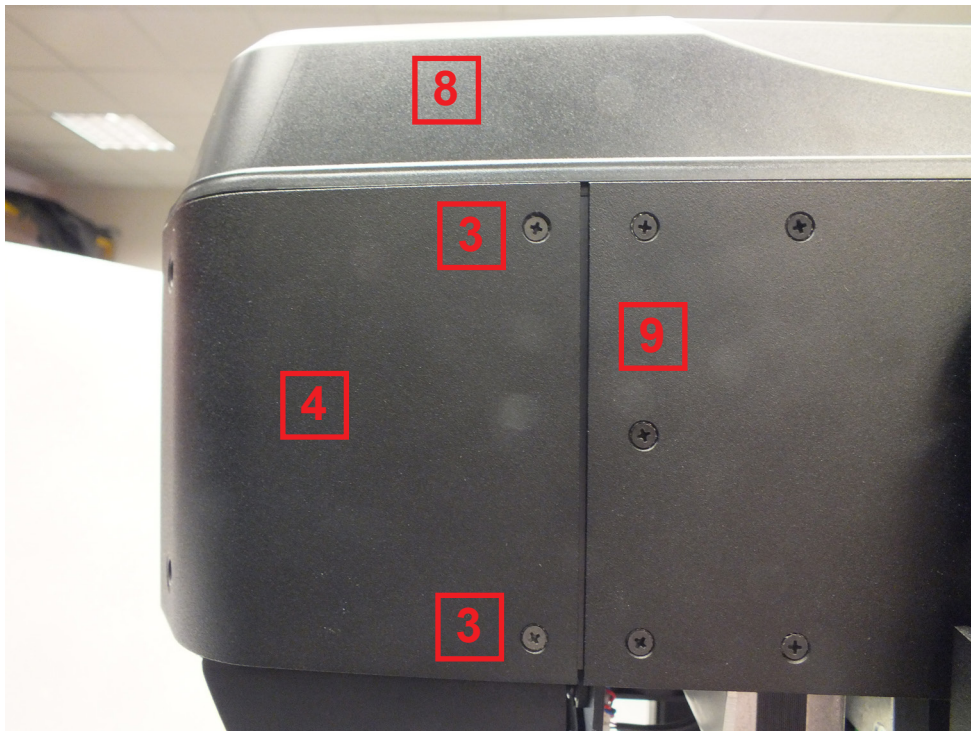

After finishing the LED light source installation and placing all covers back on the fixture, connect the fixture to mains and run the procedure LEDs Measure from the tab Service on the touch screen.

15.2. Obtaining information about the LED light source by mobile phone

You can read information about the LED light source by means of the mobile application ROBE COM. The LED light source has to be outside of the fixture.

Download and install the application ROBE COM from Google Play (for Android 5.0 and higher) or App Store (for iOS 12.0 and higher) to your mobile phone. Your mobile phone has to support NFC (Near-Field Communication).

After installing the ROBE COM, run the application by touching the icon  .
The following screen will appear:

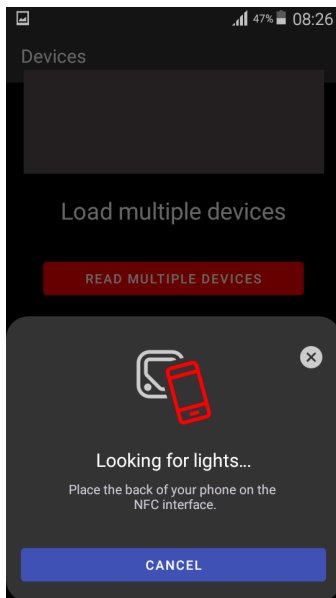

Hold the mobile phone close to the point of the LED light source PCB which is marked with the symbol NFC.

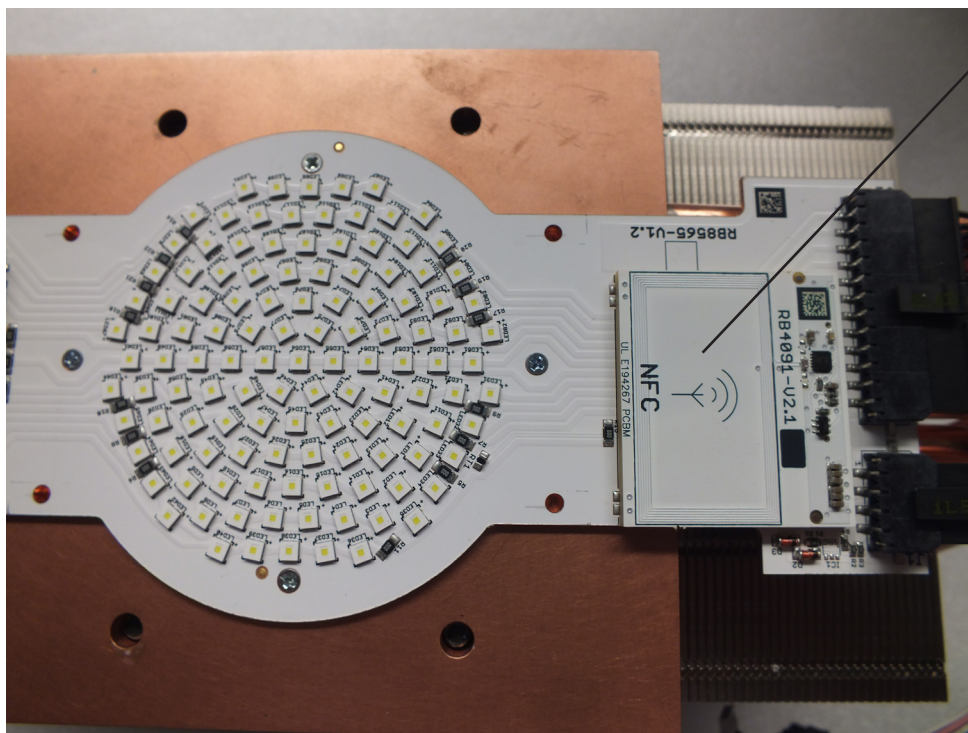

If NFC connection is OK, the screen with RDM UID of the LED light source will appear.

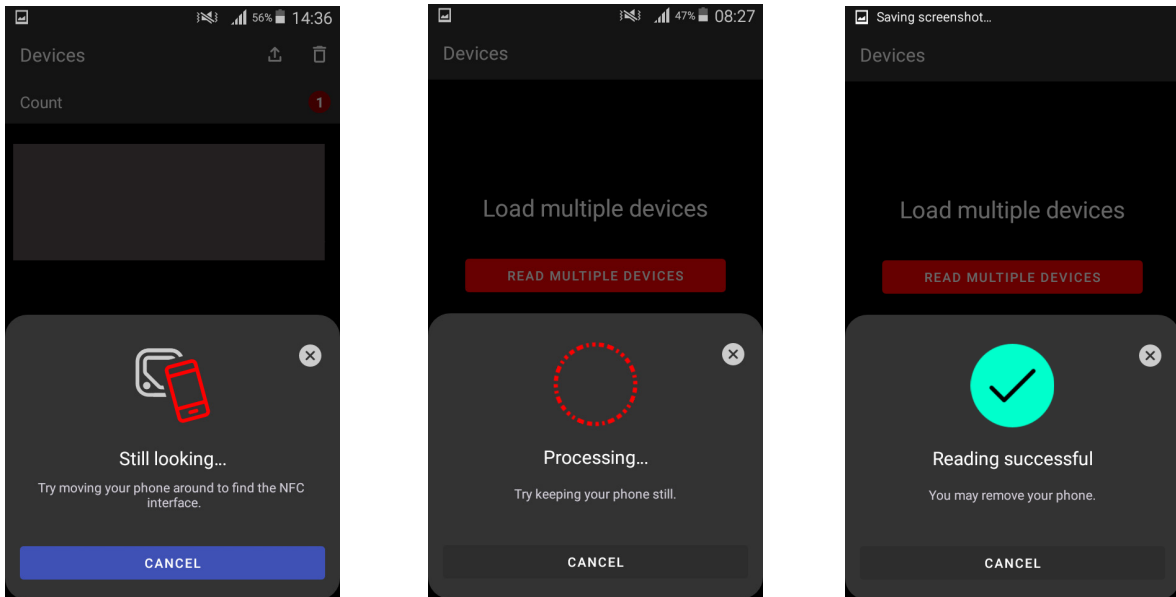

When the following screen will appear, touch the button CANCEL..

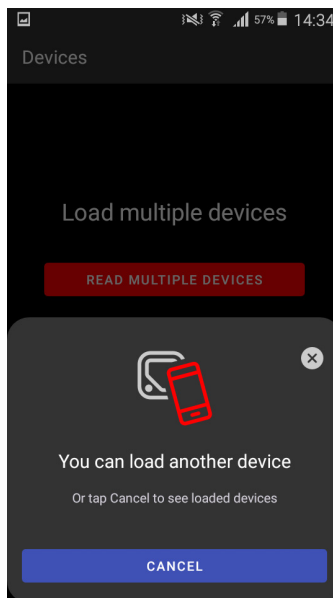

Touch the found LED module ("Robin Forte LED module") and then touch "LED engine" to read information about found LED module.

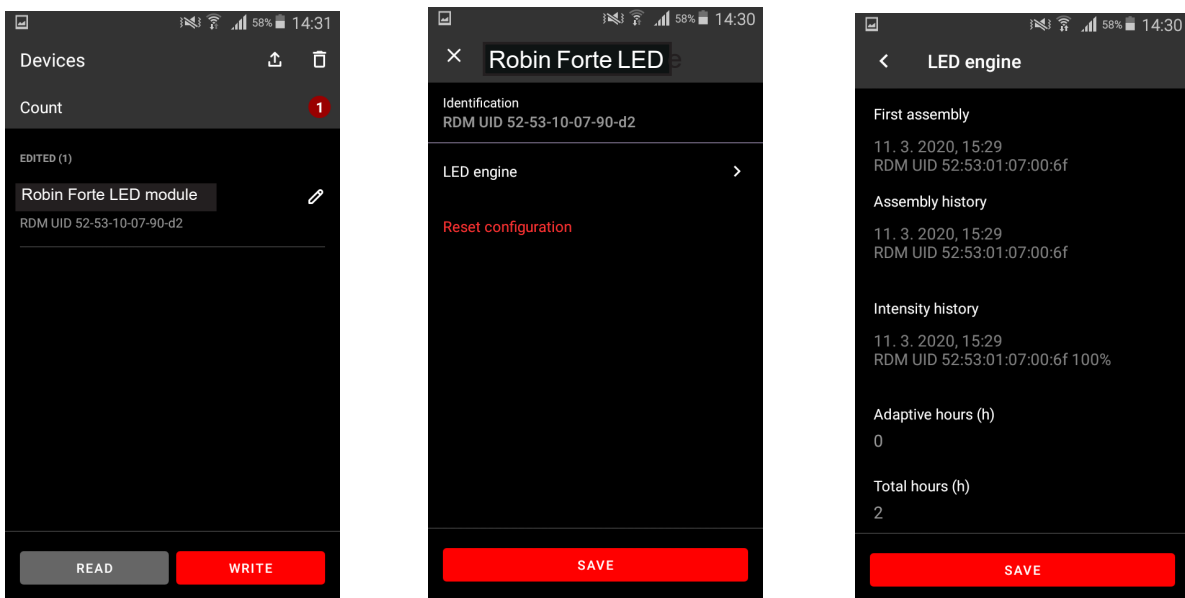

DMX protocol

Mode/Channel	DMX Value	Function	Type of control
1		Pan	
	0 - 255	Pan movement by 540° (128=default)	proportional
2		Pan Fine	
	0 - 255	Fine control of pan movement (0=default)	proportional
3		Tilt	
	0 - 255	Tilt movement by 270° (128=default)	proportional
4		Tilt fine	
	0 - 255	Fine control of tilt movement (0=default)	proportional
5		Pan/Tilt speed , Pan/Tilt time	
	0	Standard mode (0=default)	step
	1	Max. Speed Mode	step
		Pan/Tilt speed mode	
	2 - 255	Speed from max. to min.	proportional
		Pan/Tilt time mode	
	2 - 255	Time from 0.2 sec. to 25.5 sec.	proportional
6		Power/Special functions	
		Factory display menu setting: DMX Input-Wired ,Graphic display-On, Pan/tilt Mode-Speed,Blackout while pan/tilt moving-Off, Blackout while colour wheels moving-Off, Fans mode-Auto,, Quiet mode- Off,	
	0 -9	Reserved (0=default)	
		<i>To activate following functions, stop in DMX value for at least 3 s and shutter must be closed at least 3 sec. (Channel 32 „Shutter/ Strobe” must be at range: 0-31 DMX). Corresponding menu items are temporarily overridden except DMX input .</i>	
	10-14	DMX input: Wired DMX *	step
	15-19	DMX input: Wireless DMX *	step
		* function is active only 10 seconds after switching the fixture on	
	20-24	Graphic display: On	step
	25-29	Graphic display: Off	step
	30-31	Quiet mode: Fans On at blackout	step
	32-33	Quiet mode: Fans Off at blackout	step
	34-39	Reserved	
	40-44	Pan/Tilt mode: Speed	step
	45-49	Pan/Tilt mode: Time	step
	50-54	Blackout while pan/tilt moving: On	step
	55-59	Blackout while pan/tilt moving: Off	step
	60-69	Reserved	
	70-74	Blackout while colour wheels moving: On	step
	75-79	Blackout while colour wheels moving: Off	step
	80-84	Fans mode: Auto	step
	85-89	Fans mode: High	step
	90-92	Fans mode: Super Quiet	step
	93-94	Reserved	
	95-99	Dimmer curve: Super Square Law	step
	100-109	Reserved	
	110-114	Dimmer curve: Square law	step
	115-119	Dimmer curve: Linear	step
	120-124	Parking position: On	step

DMX protocol

Mode/Channel	DMX Value	Function	Type of control
1			
	125-129	Parking position: Off <i>To activate following functions, stop in DMX value for at least 3 seconds.</i>	step
	130 - 139	Total Fixture reset (without pan/tilt)	step
	140 - 149	Pan and Tilt reset	step
	150 - 159	Colour system reset	step
	160-169	Reserved	
	170 - 174	Pan reset	step
	175 - 179	Tilt reset	step
	180 - 189	Zoom/frost reset	step
	190 - 199	Barndoors/scrim reset	step
	200 - 209	Total fixture reset (including pan/tilt)	step
	210 - 239	Reserved	
	240	Disabled "Quiet mode"	step
	241 - 255	Quiet mode - fan noise control from min. to max.	proportional
7		LED frequency selection Factory display menu setting: 600Hz <i>Select PWM output frequency of LEDs. Selected PWM frequency can be fine adjusted in 127 steps up/down around selected PWM frequency on the channel below. Corresponding menu item (Frequency Setup) is temporarily overridden.</i>	
	0-4	PWM frequency from Display menu (fixture utilizes PWM frequency set in the display menu item Frequency Setup).	step
	5-9	300 Hz	step
	10-14	600 Hz (10=default)	step
	15-19	1200 Hz	step
	20-24	2400 Hz	step
	25-255	Reserved (fixture utilizes PWM frequency set in the display menu item Frequency Setup).	
8		LED frequency fine adjusting Factory display menu setting: 600Hz <i>Select desired PWM output frequency of LEDs on the channel above.</i>	
	0-1	Selected LED Frequency	step
	2	LED Frequency (step -126)	step
	3	LED Frequency (step -125)	step
	4	LED Frequency (step -124)	step
	:		
	125	LED Frequency (step -3)	step
	126	LED Frequency (step -2)	step
	127	LED Frequency (step -1)	step
	128	Selected LED Frequency (128=default)	step
	129	LED Frequency (step +1)	step
	130	LED Frequency (step +2)	step
	131	LED Frequency (step +3)	step
	:		
	252	LED Frequency (step +124)	step
	253	LED Frequency (step +125)	step
	254	LED Frequency (step +126)	step
	255	Selected LED Frequency	step
9		Max. light intensity indication and setting	

DMX protocol

Mode/Channel	DMX Value	Function	Type of control	
1	0-10	No function (0=default)		
	11-20	Indication of drop of max. light intensity	step	
		<i>A drop of max. light intensity of the fixture (compared to its original intensity) is indicated by a corresponding colour output: 0-5%, (WHITE /new LED module/) 6-10% (RED) 11-15% (GREEN) 16-20% (BLUE) 21-25% (CYAN) 26-30% (MAGENTA) 31-35% (YELLOW) 36-40% (ORANGE) Pan/tilt/zoom is set at 128 DMX (50%), Dimmer is open at 255 DMX (100%).</i>		
		<i>To set a drop of max. light intensity (compared to original light intensity), stay at DMX value for at least 3 sec. and shutter must be closed at least 3 sec. (Channel „Shutter/ Strobe” 52/54 must be at range: 0-31 DMX). Corresponding menu items are permanently overwritten.</i>		
	21-30	Set drop by 6-10% (RED)	step	
	31-40	Set drop by 11-15% (GREEN)	step	
	41-50	Set drop by 16-20% (BLUE)	step	
	51-60	Set drop by 21-25% (CYAN)	step	
	61-70	Set drop by 26-30% (MAGENTA)	step	
	71-80	Set drop by 31-35% (YELLOW)	step	
	81-90	Set drop by 36-40% (ORANGE)	step	
	91-100	Original intensity (WHITE)	step	
	101-255	Reserved		
	10		Colour wheel 1	
			Continual positioning	
0		Open/white (0=default)	proportional	
21		Deep red	proportional	
43		Deep blue	proportional	
64		Orange	proportional	
86		Green	proportional	
107		Congo blue	proportional	
128-129		Open/White	step	
		Positioning		
130-141		Deep red	step	
142-153		Deep blue	step	
154-165		Orange	step	
166-177		Green	step	
178-189		Congo blue	step	
190 - 215		Forwards rainbow effect from fast to slow	proportional	
216 - 217		No rotation	step	
218 - 243		Backwards rainbow effect from slow to fast	proportional	
244 - 249	Random colour selection by audio control (Set microphone sensitivity in menu „Personality”)	step		

DMX protocol

Mode/Channel	DMX Value	Function	Type of control
1			
	250 - 255	Auto random colour selection from fast to slow	proportional
11		Colour wheel 1 - fine positioning	
	0 - 255	Fine positioning (0=default)	proportional
12		Colour wheel 2	
		Continual positioning	
	0	Open/white (0=default)	proportional
	21	Multicolour	proportional
	43	Laser green	proportional
	64	Lavender	proportional
	86	Filter CRI 80	proportional
	107	Filter CRI 90	proportional
	128-129	Open/White	step
		Positioning	
	130-141	Multicolour	step
	142-153	Laser green	step
	154-165	Lavender	step
	166-177	Filter CRI 80	step
	178-189	Filter CRI 90	step
	190 - 215	Forwards rainbow effect from fast to slow	proportional
	216 - 217	No rotation	step
	218 - 243	Backwards rainbow effect from slow to fast	proportional
	244 - 249	Random colour selection by audio control	step
		(Set microphone sensitivity in menu „Personality“)	
	250 - 255	Auto random colour selection from fast to slow	proportional
13		Colour wheel 2 - fine positioning	
	0 - 255	Fine positioning (0=default)	proportional
14		Cyan	
	0 - 255	Cyan from min. saturation --> full cyan (0=default)	proportional
15		Magenta	
	0 - 255	Magenta from min. saturation --> full magenta (0=default)	proportional
16		Yellow	
	0 - 255	Yellow from min. saturation --> full yellow (0=default)	proportional
17		CTO	
	0 - 255	CTO from 6500K --> 3000K (0=default), HP LED module	proportional
		CTO from 5800K --> 2200K (0=default), HCF LED module	proportional
18		Green correction	
	0	Uncorrected white	step
	1-127	Minus green --> uncorrected white	proportional
	128	Uncorrected white (128=default)	step
	129-255	Uncorrected white --> Plus green	proportional
19		Virtual colour wheel	
		<i>See table "Colours on Virtual Colour Wheel" to find components of each colour</i>	
		<i>The following channels are disabled: 9-18</i>	
	0	No function (0=default)	step
	1-2	Filter 4 (Medium Bastard Amber)	step
	3-4	Filter 10 (Medium Yellow)	step
	5-6	Filter 19 (Fire)	step

DMX protocol

Mode/Channel	DMX Value	Function	Type of control
1			
	7-8	Filter 26 (Bright Red)	step
	9-10	Filter 58 (Lavender)	step
	11-12	Filter 68 (Sky Blue)	step
	13-14	Filter 71 (Tokyo Blue)	step
	15-16	Filter 79 (Just Blue)	step
	17-18	Filter 88 (Lime Green)	step
	19-20	Filter 90 (Dark Yellow Green)	step
	21-22	Filter 100 (Spring Yellow)	step
	23-24	Filter 101 (Yellow)	step
	25-26	Filter 102 (Light Amber)	step
	27-28	Filter 103 (Straw)	step
	29-30	Filter 104 (Deep Amber)	step
	31-32	Filter 105 (Orange)	step
	33-34	Filter 106 (Primary Red)	step
	35-36	Filter 111 (Dark Pink)	step
	37-38	Filter 115 (Peacock Blue)	step
	39-40	Filter 116 (Medium Blue-Green)	step
	41-42	Filter 117 (Steel Blue)	step
	43-44	Filter 118 (Light Blue)	step
	45-46	Filter 119 (Dark Blue)	step
	47-48	Filter 120 (Deep Blue)	step
	49-50	Filter 121 (Filter Green)	step
	51-52	Filter 128 (Bright Pink)	step
	53-54	Filter 131 (Marine Blue)	step
	55-56	Filter 132 (Medium Blue)	step
	57-58	Filter 134 (Golden Amber)	step
	59-60	Filter 135 (Deep Golden Amber)	step
	61-62	Filter 136 (Pale Lavender)	step
	63-64	Filter 137 (Special Lavender)	step
	65-66	Filter 138 (Pale Green)	step
	67-68	Filter 139 (Primary Green)	step
	69-70	Filter 141 (Bright Blue)	step
	71-72	Filter 147 (Apricot)	step
	73-74	Filter 148 (Bright Rose)	step
	75-76	Filter 152 (Pale Gold)	step
	77-78	Filter 154 (Pale Rose)	step
	79-80	Filter 157 (Pink)	step
	81-82	Filter 158 (Deep Orange)	step
	83-84	Filter 162 (Bastard Amber)	step
	85-86	Filter 164 (Flame Red)	step
	87-88	Filter 165 (Daylight Blue)	step
	89-90	Filter 169 (Lilac Tint)	step
	91-92	Filter 170 (Deep Lavender)	step
	93-94	Filter 172 (Lagoon Blue)	step
	95-96	Filter 179 (Chrome Orange)	step
	97-98	Filter 180 (Dark Lavender)	step
	99-100	Filter 181 (Congo Blue)	step
	101-102	Filter 197 (Alice Blue)	step

DMX protocol

Mode/Channel	DMX Value	Function	Type of control
1			
	103-104	Filter 201 (Full C.T. Blue)	step
	105-106	Filter 202 (Half C.T. Blue)	step
	107-108	Filter 203 (Quarter C.T. Blue)	step
	109-110	Filter 204 (Full C.T. Orange)	step
	111-112	Filter 205 (Half C.T. Orange)	step
	113-114	Filter 206 (Quarter C.T. Orange)	step
	115-116	Filter 247 (Filter Minus Green)	step
	117-118	Filter 248 (Half Minus Green)	step
	119-120	Filter 281 (Three Quarter C.T. Blue)	step
	121-122	Filter 285 (Three Quarter C.T. Orange)	step
	123-124	Filter 352 (Glacier Blue)	step
	125-126	Filter 353 (Lighter Blue)	step
	127-128	Filter 715 (Cabana Blue)	step
	129-130	Filter 778 (Millennium Gold)	step
	131-132	Filter 793 (Vanity Fair)	step
	133-255	Reserved	
20		CMY+CTO+Colour wheels time	
	0	Function is off (0=default)	step
	1 - 255	Time of CMY, CTO and Colour wheels movement (0.1sec-->25.5sec.)	proportional
21		Barndoors/Zoom/Frost time	
	0	Function is off (0=default)	step
	1 - 255	Time of Barndoors, zoom and frost movement (0.1 sec-->25.5 sec.)	proportional
22		Scrim positioning	
	0	No function (0=default)	step
	1-255	Scrim inserting (0.5%-->100%)	proportional
23		Scrim indexing	
	0-255	Scrim indexing 0°-360° /1.4°per 1 DMX/, (128=default) (0 DMX=0°, 64DMX=90°, 128DMX=180°, 192DMX=270°, 255DMX=360°)	proportional
24		Frost	
	0	Open (0=default) Frost cannot stay in intermediate position, it will auto-move to full/open position.	step
		Light Frost	
	1-50	Light Frost from 0% to 100%	proportional
	51-53	100% Light Frost	step
	54-63	Pulse closing from slow to fast	proportional
	64-73	Pulse opening from fast to slow	proportional
	74-83	Ramping from fast to slow	proportional
	84-86	Open	step
		Medium Frost	
	87-136	Medium Frost from 0% to 100%	proportional
	137-139	100% Medium Frost	step
	140-149	Pulse closing from slow to fast	proportional
	150-159	Pulse opening from fast to slow	proportional
	160-169	Ramping from fast to slow	proportional
	170-255	Open	step
25		Zoom	

DMX protocol

Mode/Channel	DMX Value	Function	Type of control
1	0 - 255	Zoom from max. to min. beam angle (128=default)	proportional
26		Zoom - fine	
	0-255	Fine zooming (0=default)	proportional
27		Edge colour correction	
	0-255	Fine correction of the colour of the image edge (128=default)	proportional
28		Barndoors rotation	
	0-255	Rotation 0°--> 180° (128=default)	proportional
29		Barndoor 1 - movement	
	0-255	Movement from Outward to Inward (0=default)	proportional
30		Barndoor 2 - movement	
	0-255	Movement from Outward to Inward (0=default)	proportional
31		Barndoor 3 - movement	
	0-255	Movement from Outward to Inward (0=default)	proportional
32		Barndoor 4 - movement	
	0-255	Movement from Outward to Inward (0=default)	proportional
33		Shutter/ strobe	
	0 - 31	Shutter closed	step
	32 - 63	Shutter open (32=default)	step
	64 - 95	Strobe-effect from slow to fast	proportional
	96 - 127	Shutter open	step
	128 - 143	Opening pulse in sequences from slow to fast	proportional
	144 - 159	Closing pulse in sequences from fast to slow	proportional
	160 - 191	Shutter open	step
	192 - 223	Random strobe-effect from slow to fast	proportional
	224 - 255	Shutter open	step
34		Dimmer intensity	
	0 - 255	Dimmer intensity from 0% to 100% (0=default)	proportional
35		Dimmer intensity - fine	
	0 - 255	Fine dimming (0=default)	proportional
Copyright © 2023 Robe Lighting s.r.o. - All rights reserved			
All Specifications subject to change without notice			

Robin Forte® Fresnel/Robin Forte® PC - Colours on Virtual Colour Wheel						
Colour name	Col. Wheel 1 DMX	Col. Wheel 2 DMX	Cyan DMX	Magenta DMX	Yellow DMX	CTO DMX
Filter 4 (Medium Bastard Amber)	0	0	0	132	133	196
Filter 10 (Medium Yellow)	0	0	0	6	195	255
Filter 19 (Fire)	0	0	0	234	255	0
Filter 26 (Bright Red)	135	0	0	0	0	0
Filter 58 (Lavender)	0	0	0	191	93	0
Filter 68 (Sky Blue)	0	0	188	165	0	0
Filter 71 (Tokyo Blue)	144	0	0	0	0	0
Filter 79 (Just Blue)	0	0	190	168	0	0
Filter 88 (Lime Green)	0	0	114	0	197	0
Filter 90 (Dark Yellow Green)	0	0	214	0	212	0
Filter 100 (Spring Yellow)	0	0	0	0	191	154
Filter 101 (Yellow)	0	0	0	73	193	225
Filter 102 (Light Amber)	0	0	0	92	162	155
Filter 103 (Straw)	0	0	0	0	124	225
Filter 104 (Deep Amber)	0	0	0	161	215	0
Filter 105 (Orange)	0	0	0	186	228	0
Filter 106 (Primary Red)	0	0	0	255	255	0
Filter 111 (Dark Pink)	0	0	0	184	176	0
Filter 115 (Peacock Blue)	0	0	230	0	163	0
Filter 116 (Medium Blue-Green)	0	0	230	0	174	0
Filter 117 (Steel Blue)	0	0	164	31	140	0
Filter 118 (Light Blue)	0	0	216	0	149	0
Filter 119 (Dark Blue)	0	0	255	109	0	0
Filter 120 (Deep Blue)	0	154	255	0	0	0
Filter 121 (Filter Green)	0	0	172	0	241	0
Filter 128 (Bright Pink)	0	0	0	222	169	0
Filter 131 (Marine Blue)	0	0	198	0	117	0
Filter 132 (Medium Blue)	0	0	234	0	71	0
Filter 134 (Golden Amber)	0	0	0	179	255	0
Filter 135 (Deep Golden Amber)	0	0	0	209	255	0
Filter 136 (Pale Lavender)	0	0	22	175	86	0
Filter 137 (Special Lavender)	0	0	22	141	99	0
Filter 138 (Pale Green)	0	0	80	25	167	0
Filter 139 (Primary Green)	0	0	255	0	228	0
Filter 141 (Bright Blue)	0	0	233	20	109	62
Filter 147 (Apricot)	0	0	0	164	205	0
Filter 148 (Bright Rose)	0	0	0	211	195	0
Filter 152 (Pale Gold)	0	0	0	166	176	0
Filter 154 (Pale Rose)	0	0	0	164	163	0
Filter 157 (Pink)	0	0	0	204	196	0
Filter 158 (Deep Orange)	0	0	0	206	242	0
Filter 162 (Bastard Amber)	0	0	0	146	176	0
Filter 164 (Flame Red)	0	0	0	255	243	0
Filter 165 (Daylight Blue)	0	0	201	0	50	0
Filter 169 (Lilac Tint)	0	0	0	177	135	0

Colour name	Col. Wheel 1 DMX	Col. Wheel 2 DMX	Cyan DMX	Magenta DMX	Yellow DMX	CTO DMX
Filter 170 (Deep Lavender)	0	0	45	177	88	0
Filter 172 (Lagoon Blue)	0	0	218	7	125	0
Filter 179 (Chrome Orange)	0	0	0	166	217	0
Filter 180 (Dark Lavender)	0	0	174	175	0	0
Filter 181 (Congo Blue)	0	0	187	210	0	0
Filter 197 (Alice Blue)	0	154	216	0	0	0
Filter 201 (Full C.T. Blue)	0	0	166	0	93	0
Filter 202 (Half C.T. Blue)	0	0	138	0	51	0
Filter 203 (Quarter C.T. Blue)	0	0	126	0	109	0
Filter 204 (Full C.T. Orange)	0	0	0	176	226	0
Filter 205 (Half C.T. Orange)	0	0	0	154	182	0
Filter 206 (Quarter C.T. Orange)	0	0	0	149	146	0
Filter 247 (Filter Minus Green)	0	0	0	167	108	0
Filter 248 (Half Minus Green)	0	0	0	121	98	0
Filter 281 (Three Quarter C.T. Blue)	0	0	163	0	105	0
Filter 285 (Three Quarter C.T. Orange)	0	0	0	162	219	0
Filter 352 (Glacier Blue)	0	0	197	0	99	0
Filter 353 (Lighter Blue)	0	0	210	0	131	0
Filter 715 (Cabana Blue)	0	154	255	0	0	0
Filter 778 (Millennium Gold)	0	0	0	198	255	0
Filter 793 (Vanity Fair)	0	0	0	221	140	0

Robin Forte - CTO DMX values

Colour temperature (K)	DMX value	
	HP module	HCF module
2200	*	255
2800	*	211
3000	255	196
3200	196	182
3600	154	151
4000	124	120
4500	97	84
4800	83	65
5000	75	51
5600	48	12
5800	39	0
6000	28	*
6500	0	*

Note: zoom 128DMX